

PRODUCT SPECIFICATION DRAWING

HOLDRITE® Silencer™ #271 Self-Adhesive Acoustical Insulation Liner

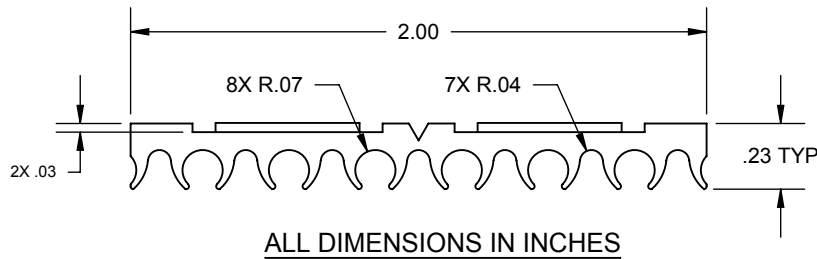
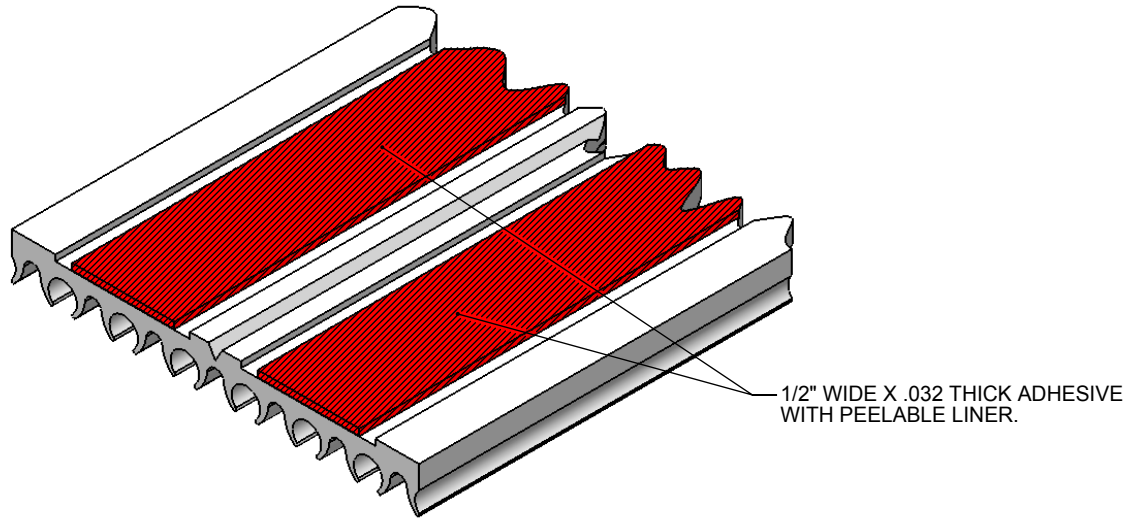

The **HOLDRITE® Silencer™ #271** is an engineered sound isolation lining with many versatile applications for use in minimizing noise transfer with plumbing and piping systems. This 2" wide strip comes in 25' rolls and can easily be cut down the center at 1" width. The self-adhesive strips provide grip to piping or hangers. Excellent for use in isolating against sound or dissimilar metal contact in hangers or through framing components.

Product Information:

- Material: TPE, natural (off-white), 35 shore A
- Temperature range: -20°F to +180°F continuous services



THIS INFORMATION IS PROPRIETARY TO HUBBARD ENTERPRISES AND IS SUBJECT TO CHANGE WITHOUT NOTICE. ANY REPRODUCTION IN PART OR WHOLE WITHOUT THE WRITTEN PERMISSION OF HUBBARD ENTERPRISES IS PROHIBITED.

.....HUBBARD ENTERPRISES.....
HOLDRITE®
"Converting Makeshift Methods into Engineered Solutions"

Product Submittal	
Job Name:	
Date:	
Part Number:	Qty:
Architect / Owner:	
Contractor:	
Notes:	