



T-3100

Telescopic Aerial Lift



DEMAND BETTER

Patented Electroguard provides 42" insulation gap in fully retracted position



Non-Insulated Aluminum Inner Boom for increased payload and less wear and tear on chassis



Hydraulic Leveling Platform Available



Platform Tilt for Easy Cleaning



- Working Height: Up to 36"
- Horizontal Reach: Up to 21' 10"
- Platform Capacity: Up to 400 lbs.



For more information about the T-3100/3300 or any of the other outstanding VERSALIFT machines, contact your authorized VERSALIFT Distributor or call 1.800.825.1085.



T-3100

Telescopic Aerial Lift

GENERAL SPECIFICATIONS

(Based on 40 in (1.02 m) Frame Height)

	T-3100-I	T-3100-N
Horizontal Reach	21 ft. 10 in. (6.7 m)	21 ft. 10 in. (6.7 m)
Maximum Platform Capacity	350 lbs. (160 kg)	350 lbs. (160 kg)
Lower Boom Lift Eye Capacity	400 lbs. (182 kg)	400 lbs. (182 kg)

WITH STANDARD PEDESTAL

	T-3100-I	T-3100-N
Height to Bottom of Platform	31 ft. (9.4 m)	31 ft. (9.4 m)
Working Height	36 ft. (11.0 m)	36 ft. (11.0 m)
Stowed Travel Height	9 ft. 10 in. (3.0 m)	9 ft. 10 in. (3.0 m)
Weight of Lift	2,200 lbs. (1000 kg)	2,200 lbs. (1000 kg)

HYDRAULIC SYSTEM

	T-3100-I	T-3100-N
Operating Pressure	2000 PSI (141 kg/cm ²)	2000 PSI (141 kg/cm ²)
Flow Rate	6GPM (22.7 lpm)	6GPM (22.7 lpm)
Filtration	10 micron return 100 mesh suction	10 micron return 100 mesh suction
System Type	Open Center	Open Center
Power Source	PTO Pump Generator Drive	PTO Pump Generator Drive

BOOM ACTION

	T-3100-I	T-3100-N
Outer/Inner Boom Travel	-25° to +85°	-25° to +85°
Inner Boom Extension	103 in. (2.62 m)	103 in. (2.62 m)
Rotation	360° Continuous	360° Continuous

UPPER BOOM INSULATION GAPS

	T-3100-I	T-3100-N
Fully Retracted	38 in. (0.97 m)	
Fully Extended	134.5 in. (3.42 m)	

NOTE:

- Specifications may vary without prior notification.
- Required GVWR can vary significantly with chassis, lift mounting location, service body, accessories, and desired payload.

OPTIONS

- Outriggers or Torsion Bar
- Outrigger/Boom Interlock System
- Hydraulic Power
- Two-Speed Manual Throttle Control
- Hydraulic Tool Circuit at the Platform
- Tool Power at the Ground Controls
- Platform, Pedestal and Capacity Variations

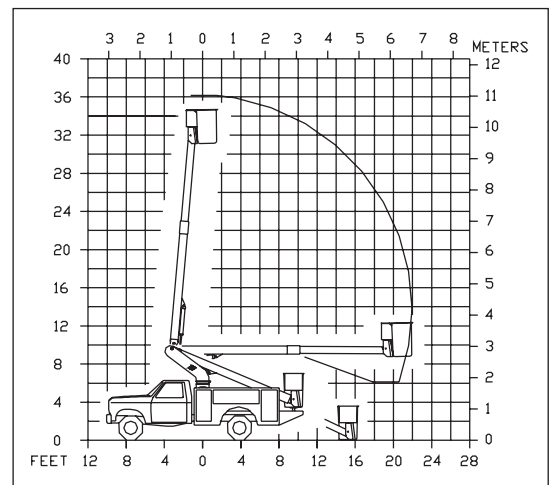

TIME
 MANUFACTURING COMPANY
 P.O. Box 20368
 Waco, TX 76702-0368
 254.399.2100
 Fax: 254.399.2651
 1.800.825.1085
 www.timemfg.com