

NEW!



VST-36/40-N

Articulated/Telescopic Aerial Lift

DEMAND BETTER

Up to 600 lbs. Platform Capacity w/out Jib

Up to 1,000 lbs. of Jib Capacity

180° Hydraulic Platform Rotation

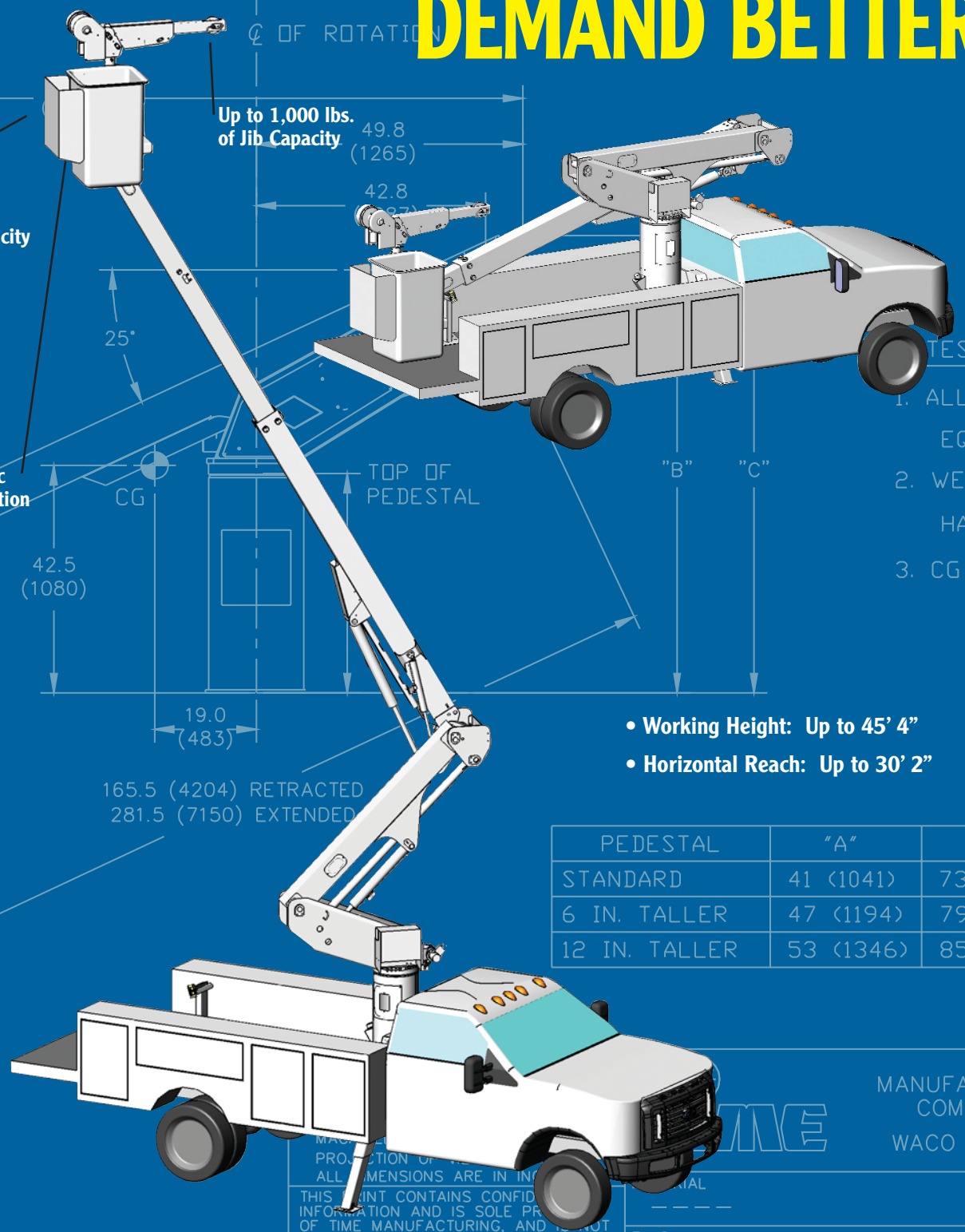

- Working Height: Up to 45' 4"
- Horizontal Reach: Up to 30' 2"

PEDESTAL	"A"	"B"
STANDARD	41 (1041)	73.6 (1870)
6 IN. TALLER	47 (1194)	79.6 (2028)
12 IN. TALLER	53 (1346)	85.6 (2173)



For more information about the All-New VST-N series or any of the other outstanding VERSALIFT machines, contact your authorized VERSALIFT Distributor or call 1.800.825.1085

THIS DOCUMENT CONTAINS CONFIDENTIAL INFORMATION AND IS SOLE PROPERTY OF TIME MANUFACTURING, AND IS NOT TO BE DISCLOSED, COPIED, OR REPRODUCED WITHOUT EXPRESSED PERMISSION OF TIME MANUFACTURING.



VST-36/40-N

Articulated/Telescopic Aerial Lift

GENERAL SPECIFICATIONS

(Based on 40" frame)

	VST-36-N	VST-40-N
Horizontal reach	26'-2"	30'-2"
Max platform capacity	600 lbs	600 lbs
Platform Rotation	180°	180°
Max jib capacity	1000 lbs	1000 lbs
Bottom of platform height	36'-4"	40'-4"
Working height	41'-4"	45'-4"
Stowed travel height	10'-6"	10'-6"

BOOM ACTION

	VST-36-N	VST-40-N
Outer/Inner boom articulation	-25 to +85°	-25 to +85°
Inner boom extension	79"	103"
Lower boom articulation	0 to 87°	0 to 87°
Rotation	360°	360°

VEHICLE REQUIREMENTS

	VST-36-N	VST-40-N
Cab to axle (minimum)	60"	84"
GVWR	17,500 lbs.	17,500 lbs.

NOTE:

1. Specifications may vary without prior notification.
2. Required GVWR can vary significantly with chassis, lift mounting location, service body, accessories, and desired payload.



- Auxiliary Outriggers
- Second Set of Tool Power Ports
- Lifting Eye
- Emergency Power
- Two-Speed Manual Throttle Control
- Various Pedestal Heights
- Manual Jib/Winch (Reduces Platform Capacity 100 lbs.)
- Hydraulic Jib/Winch (Reduces Platform Capacity 100 lbs.)

