

**VARIABLE SPEED PUMPING SYSTEMS
PRODUCT DATA BULLETIN**

**TECHNOLOGIC PUMP
CONTROLLERS**

Technologic® 5500 Series

**MULTIPLE PUMP
MULTIPLE ZONE PUMP CONTROLLER**

The Technologic 5500 pump controller is designed to provide optimum performance, reliability and energy savings.

Receiving sensor inputs, staging pumps, controlling AFD speed and monitoring the motor performance to meet system demands are the overall functions of the pump controller.

The Technologic 5500 Controller combines PID functions, setpoint modification, and system and component status into a single, central, user-friendly unit. A data-logging feature provides historical information of key events with date and time stamps. Log information includes alarms, pump run timers and pump cycle counters. The signal log displays the minimum, maximum and current values of the process variable and flow. It is also capable of displaying kilowatt-hours. The Technologic 5500's flash memory permits customized settings to be loaded and saved. These field values are permanently retained even after corruption of data due to external disturbances.

The Technologic 5500's modular design adds unlimited flexibility as it incorporates years of ITT Bell & Gossett engineering development and programming into a state of the art control system designed exclusively for pump applications.

STANDARD FEATURES

- Infinitely Adjustable PID Functions
- Individual Field Modifiable Set Points
- Pump Elapsed Time (Individual)
- Real Time Clock
- Operator Interface Diagnostics
- Multi-fault Memory and Recall
- On Screen Help Functions
- Manual and Automatic Alternation
- Automatic Start of Lag Pump upon Lead Pump Failure (in Variable or Constant Speed Mode)
- Manual System Control
- Membrane switches with LED indications of status of each switch
- Four-line Twenty Character, Illuminated LCD Display in Plain English and Engineering Units of:

Set Point(s)	Zone Number
Zone Fail	Process Variable
AFD Fault(s)	Pump Sequence
AFD % Speed	Battery Low
Pump Fault	Overload Trip
- End of Curve Protection (when optional flow meter is provided)
- Data Logging

Alarms	Pump Run Time	Signal Data
--------	---------------	-------------
- Fused 24 Volt Power Supply
- NEMA 1 Enclosure
- UL Listed
- CSA Certified, upon request
- Four Sensor Input



OPTIONAL FEATURES

- Efficiency Optimization Staging
- Automatic AFD Bypass/Transfer Option:

None	Type II	Type IV (no staging)
Type I	Type III	Type IV (staging)
- Manual AFD Bypass, internal to AFD
- BAS Communications
 - Hardwire Communications
 - RS Communications
 - Johnson Controls MetasysN2™
 - Modicon's Modbus™
 - BACnet Class II MSTP™
 - Allen-Bradley Data Highway™
 - Trane Tracer™ (requires communication bridge device)
 - LonWorks™
 - Profibus™
- Pressure Booster Options

Low Suction Cutout	High Suction Cutout
No Flow Shutdown	High System Cutout
- Audible Alarm / Push to Silence Switch
- NEMA 12 Enclosure
- NEMA 4 Enclosure
- Additional Analog and Digital Inputs & Outputs
- Flowmeter
- kW Meter with kW display
- System Differential Pressure Sensor
- Customized programming for unique pump applications and system requirements

**DIMENSIONAL
DATA**

Dimensions in inches.
Weight 90 Lbs.

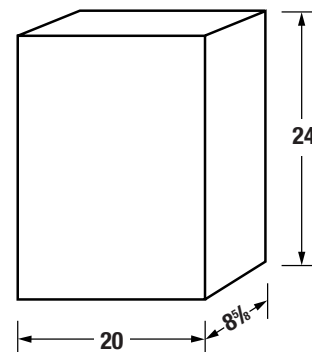

Bell & Gossett®



Technologic Pump Logic Controller

The Technologic pump logic controller assembly shall be listed by and bear the label of Underwriter's Laboratory, Inc. (UL). (Canadian Standards Association (CSA) listing available upon request.) The controller shall meet Part 15 of FCC regulations pertaining to class A computing devices. The controller shall be specifically designed for variable speed pumping applications.

The variable speed pump controller shall function to a proven program that safeguards against damaging hydraulic conditions including:

- Motor Overload
- Pump Flow Surges
- Hunting

End of Curve Protection: The pump logic controller through a factory pre-programmed algorithm, shall be capable of protecting the pumps from hydraulic damage due to operation beyond their published end-of-curve. This feature requires an optional flow meter for activation.

The pump logic controller shall be capable of staging and destaging pumps based on an **Efficiency Optimization Program** to provide the lowest kW draw. This optimization program requires an optional flow meter, kW meter, and system differential pressure sensor for activation.

The pump logic controller shall be capable of accepting _____ discrete analog inputs from zone sensor/transmitters as indicated on the plans. Analog input resolution shall be 12-bit minimum, and the controller shall scan each analog input a minimum of once every 100 milliseconds. Use of a multiplexer for multiple sensor inputs is not acceptable. All sensor/transmitter inputs shall be individually wired to the pump logic controller for continuous scan and comparison function. All analog inputs shall be provided with current limit circuitry to provide short circuit protection and safeguard against incorrect wiring of sensors.

The pump logic controller will select the analog input signal that deviates the greatest amount from its setpoint. This selected signal will be used as the command feedback input for a closed loop hydraulic stabilization function to minimize hunting. The hydraulic stabilization program shall utilize a proportional-integral-derivative control function. The proportional, integral and derivative values shall be user-adjustable over an infinite range. The scan and compare rate that selects the command setpoint and process variable signal shall be continuous and automatically set for optimum performance. Each sensor shall be scanned at least once every 100 milliseconds.

The pump controller shall be capable of controlling _____ pumps in parallel as described in the sequence of operation section.

The pump logic controller shall be self-prompting. All messages shall be displayed in plain English. The following features shall be provided:

- Multi-fault memory and recall
- On-screen help functions
- LED pilot lights and switches
- Soft-touch membrane keypad switches

The variable speed pumping system shall be provided with a user-friendly operator interface complete with membrane switches and numeric keypad. Display shall be no less than four lines with each

line capable of displaying up to twenty characters. The human interface panel shall display the following values:

- Flow in GPM (requires optional flow meter)
- Pump On/Off Status
- Pump % Speed
- Individual Alarm Conditions
- Troubleshooting Diagnostics
- User-adjustable parameters such as alternation, PID, setpoints, etc.

A data-logging feature shall be provided as a function of the pump logic controller. The Alarm log shall include the last 20 alarms with date/time stamp. The Pump data log shall display individual pump run timers and pump cycle counters. A System data log will indicate operation mode, system cycles and panel power cycles, each with date/time stamp. A Signal log shall be provided to display the maximum and minimum values with date/time stamps for each process variable and flow, when optional flow meter is provided. The Signal log shall also be capable of displaying the cumulative value of kilowatt-hours for each pump and of system minimum and maximum flow along with individual counter reset capability.

The Logic controller shall incorporate a Flash Memory for saving and reloading customized settings. These field determined values shall be permanently retained in Flash memory for automatic reloading of the site specific setup values in the event of data corruption due to external disturbances. The Controller shall also employ a sensor setup copy feature.

The pump controller shall be capable of communicating with the Building Automation System (BAS) by both hard-wired and serial communications. The following communication features shall be provided to the BAS in "hardwired" form via 4-20ma analog signals and digital outputs:

- Remote system start/stop (dry contact supplied by BAS)
- Failure of any system component (qty. 1, relay output from pump controller)
- Process variable (qty. __, 4-20ma analog output supplied by pump controller)
- AFD speed (qty. 1, 0-10VDC analog output supplied by pump controller)
- Optional: Pump on/off status (qty. __, relay output supplied by pump controller)

The following communication features shall be provided to the Building Automation System via an RS-485 port (optional hardware required) utilizing Johnson Controls Metasys N2™, Modicon's Modbus™, BACnet Class II MSTP™, Profibus™, Trane Tracer™, LonWorks™, or Allen-Bradley Data Highway™ protocol:

- All sensor process variables
- Individual zone setpoints
- Individual pump failure
- Individual pump on/off status
- Individual AFD on/off status
- AFD speed
- Individual AFD Failure
- AFD bypass status (if automatic)
- Individual sensor failure

The pump logic controller shall be a Bell & Gossett Technologic 5500. Enclosure shall be NEMA 1.



Bell & Gossett

USA
Bell & Gossett
8200 N. Austin Avenue
Morton Grove, IL 60053
Phone: (847) 966-3700
Facsimile: (847) 966-9052
<http://www.bellgossett.com>



INTL.
Bell & Gossett / Export Dept.
8200 N. Austin Avenue
Morton Grove, IL 60053
Phone: (847) 966-3700
Facsimile: (847) 966-8366
<http://www.bellgossett.com>

CANADA
Fluid Products Canada
55 Royal Road
Guelph, Ontario,
N1H 1T1, Canada
Phone: (519) 821-1900
www.ittfpc.ca