

Main Steam Vents

For Steam Vent selection information, please refer to "Selection Guidelines" on page 133.

How to Select Steam Vents

Model Number	Radiator (Angle Type)	Convactor (Bottom Inlet)	Unit Heater	Mains	Thermostatic Vent (only)	Remarks
1A	X					Adjustable Orifice
70A	X					Fixed Orifice
40	X					Fixed Orifice
1B		X				Adjustable Orifice
41		X				Fixed Orifice
43		X				Fixed Orifice
45		X				Fixed Orifice
71A		X				Fixed Orifice
71B		X				Fixed Orifice
71C		X				Fixed Orifice
508		X				Moisture Type
4A				X		Small Systems
75				X		Low Pressure
75H				X		High Pressure
76				X		Vacuum Systems
3					X	Paul Systems
74			X			Unit Heaters
4					X	Small Systems
8C					X	High Pressure

Model 4A Part No. 401413

Air Valve (non-vacuum)

- Float-type thermostatic vent
- For residential or small one-pipe or two-pipe systems
- Single non-adjustable port
- ½" NPT female and ¾" NPT male straight shank
- Install 6-10" (150-250mm) above horizontal return and 18" (450mm) above the boiler water line
- Maximum operating pressure 2 psig (0.13 bar)*
- Maximum pressure 10 psig (0.7 bar)

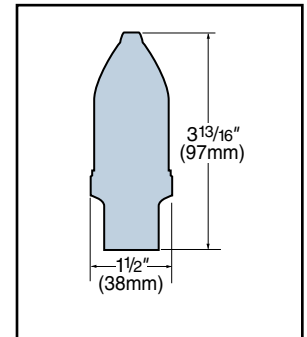

Model 75 Part No. 401434

75H Part No. 401437

Air Valve (non-vacuum)

- Float-type thermostatic vent
- For medium and large systems
- Single non-adjustable port
- ½" NPT female and ¾" NPT male straight shank
- Maximum operating pressure*
 - Model 75 3 psig (0.2 bar)
 - Model 75H 10 psig (0.7 bar)
- Maximum pressure 15 psig (1.0 bar)

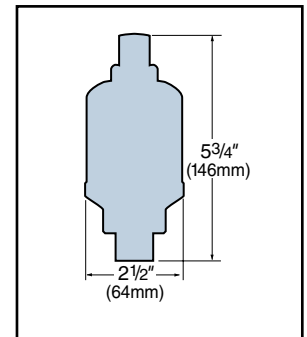

*Drop away pressure (maximum pressure against which the vent can open).

Vents

Model 76 Part No. 401432

Vacuum Valve

- Float-type thermostatic vent
- For medium and large one-pipe vacuum systems
- Single non-adjustable port
- 1/2" NPT female and 3/4" NPT male straight shank
- Install 6-10" (150-250mm) above horizontal return and 8" (450mm) above the boiler water line
- Maximum operating pressure 3 psig (0.2 bar)
- Maximum pressure 15 psig (1.0 bar)

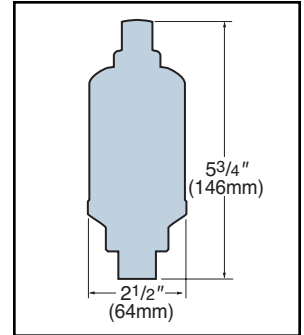

Installation

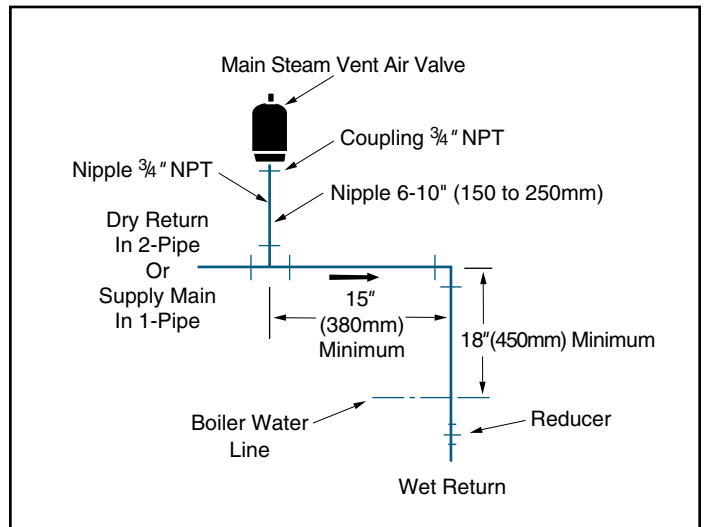

To prevent steam vents from sputtering water or damage from water hammer, observe the minimum elevations shown.

High Pressure Steam Vent

Model 8C Angle Part No. 402002
High Pressure Balanced Pressure Air Valve

- Thermostatic vent (no float)
- Install at the high point in piping or on equipment to quickly vent air from the steam space.
- Discharge may be piped to a safe area or into vented return line.
- 1/4" (6mm) orifice
- Inlet 1/2" NPT male union connection
- Outlet 1/2" NPT female
- Bronze body and cap
- Stainless steel element
- Maximum operating pressure 125 psig (8.6 bar)

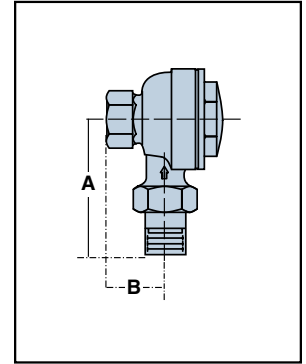

Dimensions, in. (mm)

Model	Pattern	NPT Size	A	B
8C-2	Angle	1/2	2 ²⁷ / ₃₂ (72)	1 ¹ / ₄ (32)

Air make up coil with F&T Float & Thermostatic trap draining into a wet return line

Note: A separate thermostatic trap is added to vent air into the dry return line.

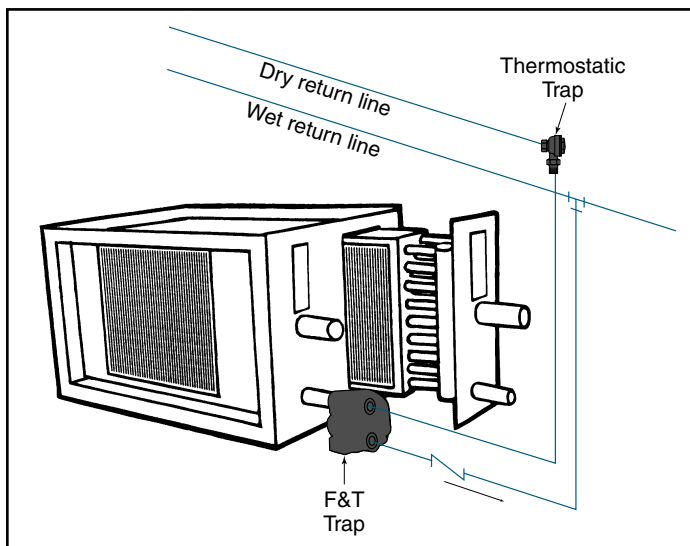

Radiator Steam Vents

Model 1A Part No. 401422

Air Valve (non-vacuum)

- Float-type vent
- Adjustable port for true proportional venting – 6 port settings from slow (1) to fast (6)
- 1/8" NPT angle connection
- Maximum operating pressure 1 1/2 psig (0.1 bar)*
- Maximum pressure 10 psig (0.7 bar)



Model 70A Part No. 401443

Air Valve (non-vacuum)

- Float-type vent
- Single non-adjustable port
- Meets Federal Specification WW-V-151 for Type 1 Non-Adjustable Valves
- 1/8" NPT angle connection
- Maximum operating pressure 11 psig (0.8 bar)*
- Maximum pressure 15 psig (1.0 bar)



Model 40 Part No. 401440

Air Valve (non-vacuum)

- Float-type vent
- For ordinary one-pipe system that doesn't require proportional venting
- Single non-adjustable port
- 1/8" NPT angle connection
- Maximum operating pressure 6 psig (0.4 bar)*
- Maximum pressure 10 psig (0.7 bar)



Typical Installation

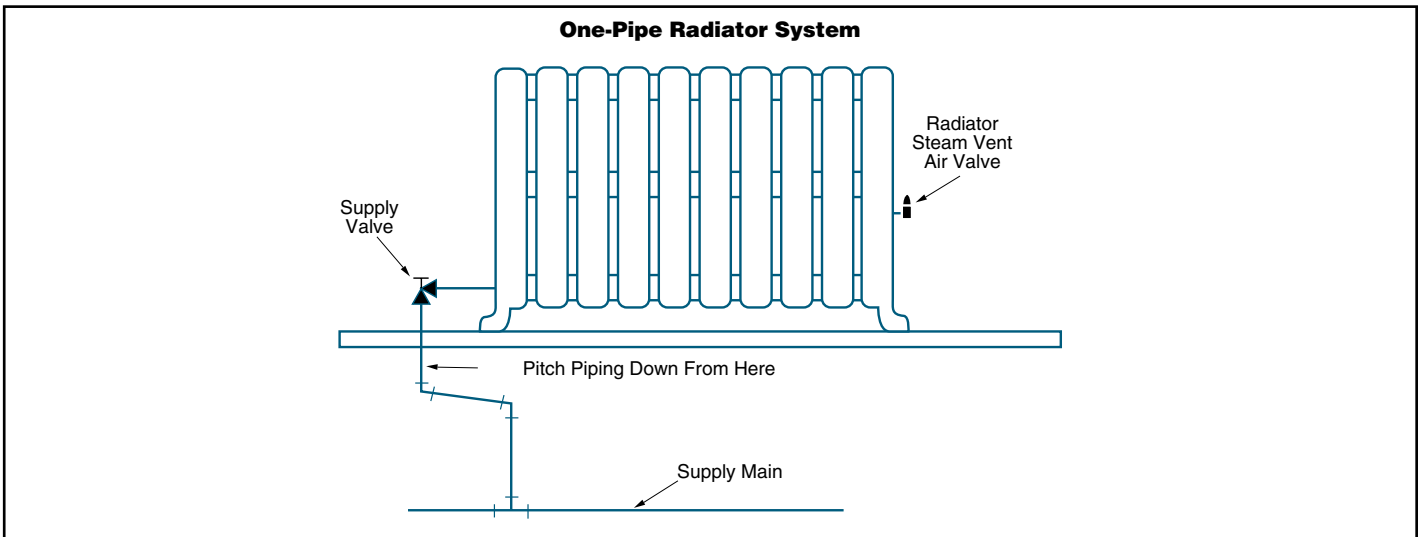

*Drop away pressure (maximum pressure against which the vent can open).

Special Steam Vents

Model 3 Part No. 401419

Steam Air Line Valve

- Thermostatic vent (no float)
- For Air Line or Paul Systems
- Inlet 1/8" NPT, outlet 1/4" NPT
- Maximum operating pressure 25 psig (1.7 bar)* to vacuum
- Maximum pressure 25 psig (1.7 bar)

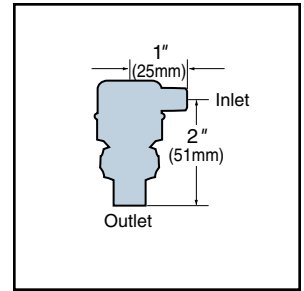

Model 74 Part No. 401429

Steam Unit Heater Air Valve

- Float-type thermostatic vent
- Single non-adjustable port
- 1/2" NPT female and 3/4" NPT male straight shank
- Install 6-10" (150-250mm) above horizontal return and 18" (450mm) above the boiler water line
- Maximum operating pressure 35 psig (2.4 bar)*
- Maximum pressure 35 psig (2.4 bar)

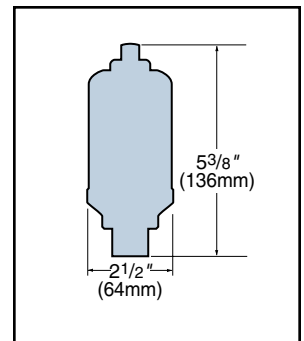

Installation

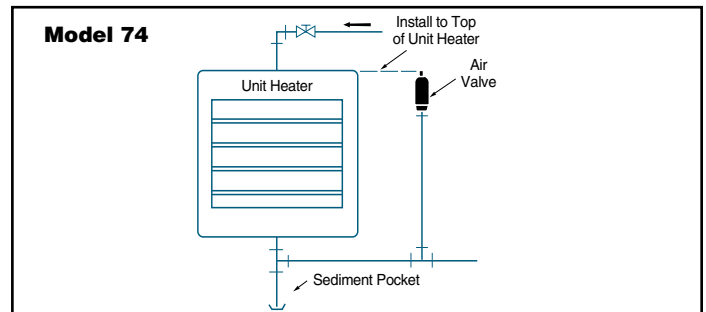

Model 4 Part No. 401416

Quick Valve

- Thermostatic air vent
- For steam systems and process equipment
- Operates on temperature change only; does not close against water
- Must be installed 6-10" (150-250mm) above horizontal return and 18" (450mm) above the boiler water line
- 1/2" NPT female and 3/4" NPT male straight shank
- Maximum operating pressure 25 psig (1.7 bar)*
- Maximum pressure 25 psig (1.7 bar)

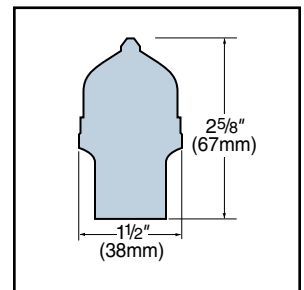

Installation

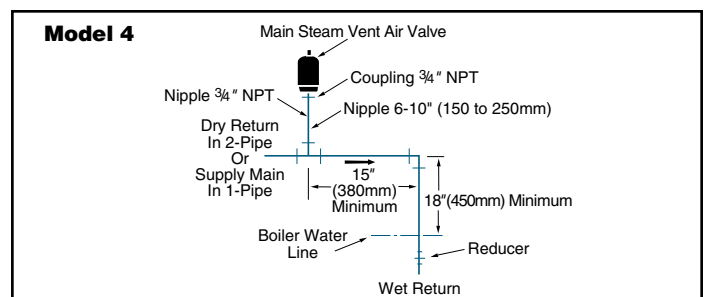

To prevent steam vents from sputtering water or damage from water hammer, observe the minimum elevations shown.

*Drop away pressure (maximum pressure against which the vent can open).

Convector Steam Vents

Model 1B Part No. 401425

Air Valve (non-vacuum)

- Float-type vent
- Adjustable port for true proportional venting – 6 port settings from slow (1) to fast (6)
- Telescopic siphon tube
- ¼" NPT straight shank
- Maximum operating pressure 1½ psig (0.1 bar)*
- Maximum pressure 10 psig (0.7 bar)



**Air Valve
Model 1B**

Model 41 Part No. 401455

43 Part No. 401458

45 Part No. 401461

Air Valve (non-vacuum)

- Single non-adjustable port
- For small steam systems
- Telescopic siphon tube with angle cut assures drainage
- ½" NPT straight shank (41)
- ¼" NPT straight shank (43)
- ½" NPT female and ¾" NPT male straight shank (45)
- Maximum operating pressure 6 psig (0.4 bar)*
- Maximum pressure 10 psig (0.7 bar)



**Air Valve
Model 41, 43, 45**

Model 71A Part No. 401470

71B Part No. 401464

71C Part No. 401467

Air Valve (non-vacuum)

- Float-type vent
- Single non-adjustable port
- Meets Federal Specification WW-V-151 for Type 1 Non-Adjustable Valves
- Telescopic siphon tube with angle cut assures drainage
- ½" NPT straight shank (71A)
- ¼" NPT straight shank (71B)
- ½" NPT female and ¾" NPT male straight shank (71C)
- Maximum operating pressure 11 psig (0.8 bar)*
- Maximum pressure 15 psig (1.0 bar)



**Air Valve
Model 71A, 71B, 71C**

Model 508 Part No. 401475

Air Valve (non-vacuum)

- Disc-type vent
- Built-in Check Valve
- For automatic venting of convectors and radiators
- Can be disassembled to clean without removing from line
- ½" NPT straight shank
- Maximum steam pressure of 15 psig (1.0 bar)



**Air Valve
Model 508**

*Drop away pressure (maximum pressure against which the vent can open).

Water Vents

For Water Vent selection information, please refer to "Selection Guidelines" on page 134.

How to Select Water Vents

Model Number	Radiator	Convactor	Mains	Built-in Vacuum Check	Maximum Operating Pressure psig (bar)	Remarks
77	X	X			50 (3.5)	Small Systems
78			X	X	150 (10.3)	High Pressure
79			X	X	75 (5.2)	Low Pressure
790		X			30 (2.1)	Small Systems
791		X	X		50 (3.5)	Small Systems
792			X		250 (17.3)	Cast Iron Body
550		X			100 (6.9)	Air Chamber
508	X	X			50 (3.5)	Moisture Type

Model 77 Part No. 401497

Water Vent Valve

- For efficient releasing of air in hydronic heating systems, such as baseboard radiators, convactor radiators and small heating units
- 1/8" NPT straight shank
- Maximum operating pressure 50 psig (3.5 bar)*
- Maximum temperature 240°F (116°C)

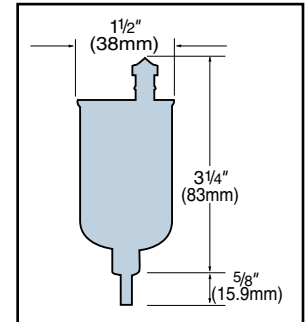

Model 78 Part No. 401485

Water Main Vent Valve

- For use on high pressure hot or cold water or glycol mains and process applications with specific gravity greater than 0.7
- Cast brass body
- Tapped at top for 1/8" NPT safety drain connection for discharging moisture
- Body unscrews for easy cleaning
- Built-in Check Valve
- 3/4" NPT straight shank
- Maximum operating pressure 150 psig (10.3 bar)*
- Maximum hydrostatic pressure 450 psig (31.1 bar)
- Maximum temperature 250°F (121°C)

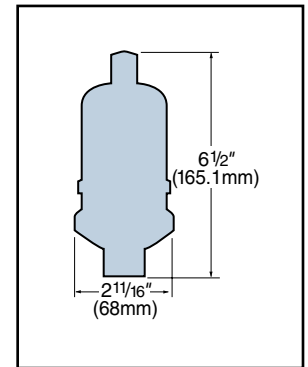

Model 79 Part No. 401488

Water Main Vent Valve

- For use on hot or cold or glycol water mains and process applications with specific gravity greater than 0.7
- Tapped at top for 1/8" NPT safety drain connection for discharging moisture
- Removable top
- Built-in Check Valve
- 1/2" NPT female and 3/4" NPT male straight shank
- Maximum operating pressure 75 psig (5.2 bar)*
- Maximum hydrostatic pressure 200 psig (13.8 bar)
- Maximum temperature 250°F (121°C)

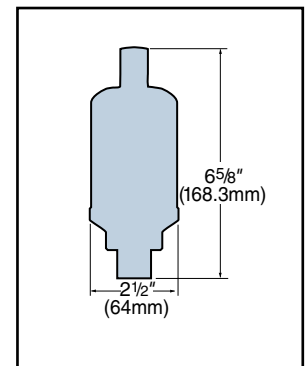

*Drop away pressure (maximum pressure against which the vent can open).

Vents

Model 790 Part No. 401479

Water Vent Valve

- For removing air from convectors, baseboard and wall radiation
- Safety drain connection for discharging moisture
- Fitting and ferrule for 3/16" (4.8mm) OD tubing
- Telescopic siphon tube
- 1/8" NPT straight shank
- Maximum operating pressure 30 psig (2.1 bar)*
- Maximum pressure 30 psig (2.1 bar)

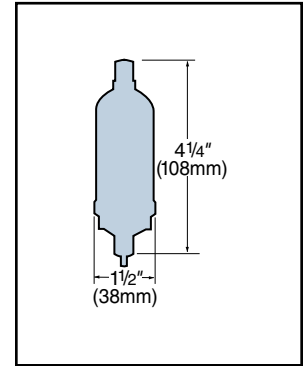

Model 791 Part No. 401482

Water Vent Valve

- For convectors and small mains
- Safety drain connection for discharging moisture
- Fitting and ferrule for 3/16" (4.8mm) OD tubing
- Telescopic siphon tube
- 1/4" NPT straight shank
- Maximum operating pressure 50 psig (3.5 bar)*
- Maximum pressure 50 psig (3.5 bar)

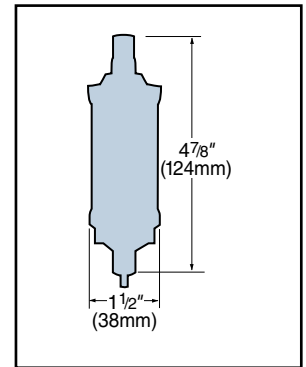

Model 792 Part No. 401494

High Pressure Water Vent Valve

- For releasing air from hot or cold water or glycol mains, hydronic heating and chilling systems, storage and processing tank filters, centrifugal pumps with specific gravity greater than 0.7
- Cast iron body and cover, stainless steel interior
- Maximum operating pressure 250 psig (17.3 bar)*
- Maximum hydrostatic pressure 350 psig (24.2 bar)
- Maximum temperature 300°F (149°C)

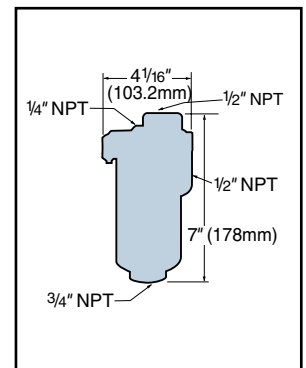

Model 792 Capacity	
Water Pressure psig (bar)	Air Discharge to Atmosphere cu. ft./min. (cu. m/min.)
100 (6.9)	10 (.28)
150 (10.3)	15 (.42)
200 (13.8)	20 (.57)
250 (17.3)	25 (.70)

*Maximum pressure against which the vent can open.

Model 550 Part No. 401476

Air Chamber

- For use on convectors which are not provided with built-in air chambers or air collection fittings
- Brass construction.
- ¼" NPT straight shank connection tapped at the top for ½" NPT connection
- 6 cubic inch (98.3cm) volume
- Maximum water pressure 100 psig (6.9 bar)
- Maximum steam pressure 25 psig (1.7 bar)

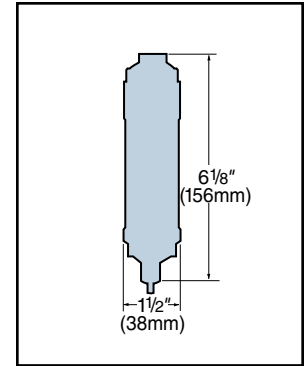

Model 508 Part No. 401475

Water Vent Valve

- For automatic or manual venting systems
- Ideal for use with Model 550 Air Chamber
- Disc-type vent
- Built-in check valve
- Cartridge with discs can be replaced without draining the system
- ½" NPT straight shank
- Maximum water pressure 50 psig (3.5 bar)
- Maximum pressure 50 psig (3.5 bar)

