

**TITEN®** Screws

Titen screws are 3/16" and 1/4" diameter masonry screws for attaching various components to concrete and masonry. Available in hex and phillips head designs in three colors. Use with appropriately sized Titen drill bits included with each box.  
**CODES:** See page 12 for Code Reference Key Chart.

**WARNING:** Industry studies show that hardened fasteners can experience performance problems in wet or corrosive environments. Accordingly, use this product in dry and noncorrosive environments only or provide a moisture barrier.

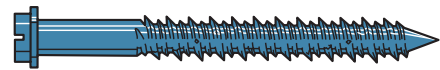

Titen Hex Head

**Titen Screw Anchors for Concrete**

Titen Dia. (in)	Drill Bit Dia. (in)	Embed. Depth (in)	Critical Spacing (in)	Critical Edge Dist. (in)	Allowable Loads				Code Ref.
					Concrete		CMU		
					Tension	Shear	Tension	Shear	
3/16	5/32	1	2 1/4	1 1/8	125	255	110	205	170
3/16	5/32	1 1/2	2 1/4	1 1/8	305	415	—	—	
1/4	3/16	1	3	1 1/2	145	225	150	250	
1/4	3/16	1 1/2	3	1 1/2	365	400	—	—	

1. Allowable loads may not be increased for short term loading due to wind or seismic forces.
2. Concrete shall have a minimum  $f'_c = 2000$  psi. CMU is based on installation into face shell of hollow and grout-filled CMU.
3. The attached member or element may govern the allowable load. The designer shall verify allowable load.
4. Refer to the Simpson Strong-Tie® *Anchoring and Fastening Systems for Concrete and Masonry* catalog (form C-SAS) for complete information on the Titen screws (see page 191 for details).

**WM/WMI/WMU Hangers**

See pages 96-105 for sizes, fasteners and load information.

WMs are designed for use on standard 8" grouted masonry block wall construction.

**MATERIAL:** See tables on pages 70-73, 96-105, 122;

WM, WMI, WMU—12 ga. top flange and stirrup

**FINISH:** Simpson Strong-Tie® gray paint; hot-dip galvanized available; specify HDG.

**INSTALLATION:** • Use all specified fasteners.

- WM—two 16d duplex nails must be installed into the top flange and embedded into the grouted wall. Verify that the grouted wall can take the required fasteners specified in the table.
- **MID-WALL INSTALLATION:** Installed between blocks with duplex nails cast into grout with a minimum of one grouted course above and below the top flange and one #5 vertical rebar minimum 24" long in each adjacent cell.
- **TOP OF WALL INSTALLATION:** Install on top of wall to a grouted beam with masonry screws.
- Refer to technical bulletin T-SLOPEJST for information regarding load reductions on selected hangers which can be used without modification to support joists which have shallow slopes ( $\leq 3/4:12$ ) (see page 191 for details).

**OPTIONS:** • See Hanger Options, pages 181-183 for hanger modifications and associated load reductions.

- WMU may not be modified.

**CODES:** See page 12 for Code Reference Key Chart.

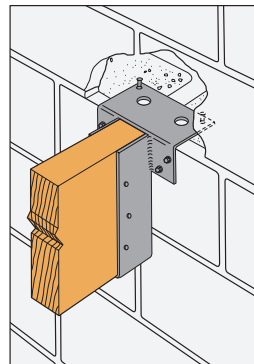

WMU Mid-Wall Installation

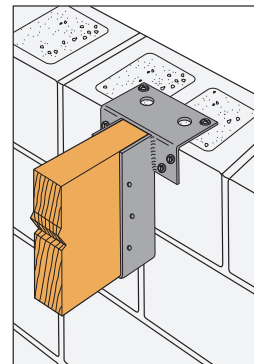

WMU Top of Wall Installation

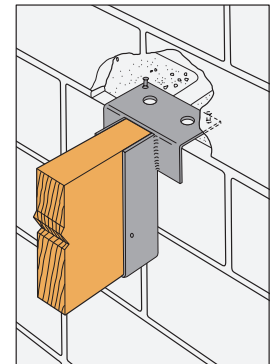

WM Mid-Wall Installation

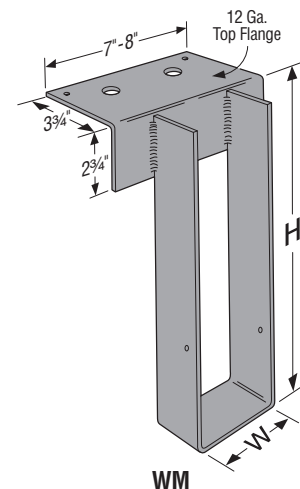

Model	Joist		Fasteners			Masonry Allowable Loads		Code Ref.
	W	H	Top	Face	Joist	Uplift (160)	Download (100/115/125)	
WM/WMI	1 1/2 to 7 1/2	3 1/2 to 30	2-16d DPLX	—	2-10dx1 1/2	—	4175 <sup>2</sup>	WM = IL12, L12 WMI = 170
			2-1/4x1 3/4 Titen	—	2-10dx1 1/2	—	3380 <sup>2</sup>	
WMU	1 1/2 to 7 1/2	9 to 28	2-16d DPLX	4-1/4x1 1/4 Titen	6-10dx1 1/2	625	4175 <sup>3</sup>	170
			2-1/4x1 3/4 Titen	4-1/4x1 3/4 Titen	6-10dx1 1/2	545	3380 <sup>3</sup>	

1. Uplift loads have been increased 60% for wind or earthquake loading; no further increase allowed. For normal loading applications such as cantilever construction refer to Simpson Strong-Tie® Connector Selector™ software or conservatively divide the uplift load by 1.6.
2. Mid-Wall Installation (see installation notes and figures) – minimum  $f'_m = 1500$  psi.
3. Top of Wall Installation (see installation notes and figures) – minimum  $f'_m = 1500$  psi.
4. Products shall be installed such that the Titen screws are not exposed to the weather.
5. For hanger heights exceeding the joist height, the allowable load is 0.50 of the table load.
6. **NAILS:** 16d DPLX = 0.162" dia. x 3 1/2" long, 10dx1 1/2 = 0.148" dia. x 1 1/2" long. See page 16-17 for other nail sizes and information.