

GBC Gable Brace Connector



This product is preferable to similar connectors because of a) easier installation, b) higher loads, c) lower installed cost, or a combination of these features.

The GBC provides improved anchorage of gable bracing to the exterior wall. Installation flexibility for brace angle. GBC has tension and compression capacities.

MATERIAL: 16 gauge

FINISH: Galvanized

INSTALLATION:

- Use all specified fasteners. See General Notes.
- The GBC must be installed in pairs to achieve full load capacity.

CODES: See page 12 for Code Reference Key Chart.

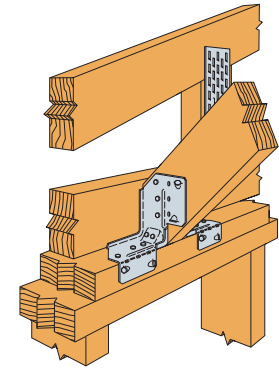
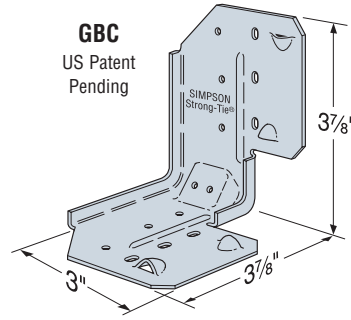

Typical GBC Installation

| Model No. | Qty Req'd | Fasteners per Connector | | DF/SP Allowable Loads (160) Perpendicular to Endwall (F ₂) | | | | SPF/HF Allowable Loads (160) Perpendicular to Endwall (F ₂) | | | | Code Ref. |
|-----------|-----------|-------------------------|------------|--|-------------------|-------------------|-------------------|---|-------------------|-------------------|-------------------|-----------|
| | | | | Toward GBC | | Away from GBC | | Toward Anchors | | Away from Anchors | | |
| | | Gable Brace | Top Plates | Gable Brace Angle | Gable Brace Angle | Gable Brace Angle | Gable Brace Angle | Gable Brace Angle | Gable Brace Angle | Gable Brace Angle | Gable Brace Angle | |
| GBC | 2 | 5-8dx1½ | 7-8d | 40°-45° | 46°-60° | 40°-45° | 46°-60° | 40°-45° | 46°-60° | 40°-45° | 46°-60° | I13, F12 |
| | | | | 635 | 570 | 425 | 325 | 535 | 480 | 355 | 275 | |

1. For 1¼ x 3½ (or larger) LVL gable brace, the allowable load at 40° to 45° is 635 lbs. towards anchors, 515 lbs. away from anchors.
2. Loads have been increased 60% for wind or earthquake loading with no further increase allowed; reduce where other loads govern.
3. Use a minimum 2x4 gable brace. Larger members may be used.
4. **NAILS:** 8d = 0.131" dia. x 2½" long, 8dx1½ = 0.131" dia. x 1½" long. See page 16-17 for other nail sizes and information.

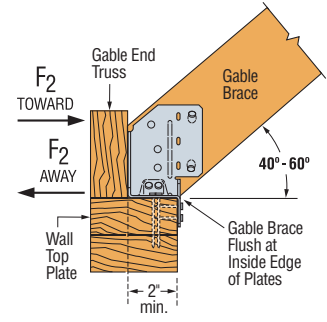

Typical Sloped Installation

GBC INSTALLATION SEQUENCE

| Slope | H Dimension |
|-------|-------------|
| 40° | 2 15/16 |
| 50° | 3 1/16 |
| 60° | 3 3/16 |

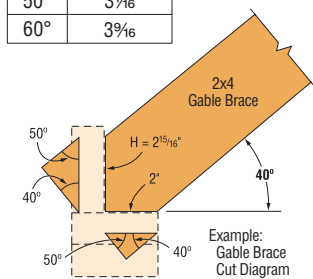

STEP 1

Double angle cut the gable brace to sit flat on the wall double top plate and flush against the gable end truss for 2x4 top plate. The double angle cuts should form a 90° angle on the end of the gable brace.

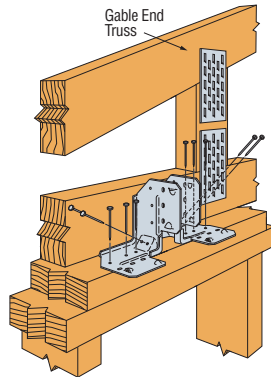

STEP 2

Set each GBC on top of the double top plate so that the bend line slots are flush with the inside edge of the double top plate. Install fasteners into the top of the double top plate.

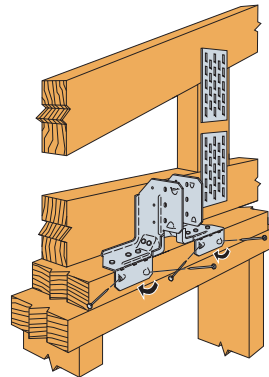

STEP 3

Bend GBC legs (*one time only*) over the inside of the double top plate and install fasteners.

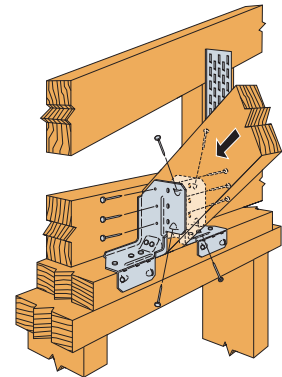

STEP 4

Install fasteners into the gable brace.

NOTE: Attach the other end of the gable brace to blocking at the roof diaphragm as directed by the Designer.