

Cavity Shaftwall Systems



09 21 16.23

CAVITY SHAFTWALL SYSTEMS

DESCRIPTION

Gypsum drywall shaft construction has become the preferred alternative to traditional masonry shafts. One-inch Shaftliner board was developed as a lightweight, easy-to-install replacement for masonry in the interior core of buildings for shaftwalls, stairwells, other vertical chases and mechanical enclosures. Shaftliner board is also used as a component of 2" solid partitions, and area separation walls with a layer of 1/2" Regular or Fire-Shield Gypsum Board attached to each side.

Historically, heavy masonry weighing 20 to 45 lbs. per square foot was used for shaftwall construction. With the use of Shaftliner, shaftwall assemblies weigh in at a remarkably low 10 to 13 lbs. per square foot.

The benefits of gypsum drywall shaft systems go far beyond the difference in weight alone. The core wall of a shaft can be installed from the exterior of the shaft and requires no scaffolding. Erection is speedy and clean. Shaftliner also provides excellent sound control and can achieve the fire ratings necessary for today's building construction. Best of all, gypsum shaftwall systems are more economical than masonry shaft construction.

National Gypsum produces Shaftliner board with green moisture-resistant paper or purple moisture/mold/mildew resistant paper on both sides with a beveled edge configuration allowing for simple installation into the Shaftwall System framing.

Cavity Shaftwall systems are a nonload-bearing drywall partition made up of two basic components, gypsum board and metal framing. Gypsum board includes 1" Fire-Shield Shaftliner or 1" Fire-Shield Shaftliner XP panels, 1/2" Fire-Shield C

and 5/8" Fire-Shield Gypsum Board face panels. 1/2" XP Fire-Shield C or 5/8" XP Fire-Shield Gypsum Board face panels may be utilized for extra protection against mold and mildew. The framing includes I-Studs, C-T Studs and C-H studs with integral tabs/flange which hold the panels in place and J Track for runners at top and bottom, as well as vertically at partition ends and to frame openings.

The Cavity Shaftwall Systems were developed to enclose elevator shafts and other vertical chases in buildings where it is advantageous to erect these walls from one side only and where fire resistance and resistance to air pressures are required.

National Gypsum Company Cavity Shaftwall Systems may be constructed with C-T, C-H or I-Stud shaftwall framing.

Lightweight. Cavity Shaftwall Systems are very lightweight compared to conventional shaftwalls, weighing approximately 10 lbs. per sq. ft. of wall when finished with two layers of 1/2" Fire-Shield C Gypsum Board.

Economical. Shafts can be quickly enclosed with shaftwall framing and Shaftliner under most conditions in which installers can work, well below temperature limitations for finish gypsum board applications.

Practical. The 1" Shaftliner is faced with light green moisture-resistant paper and Shaftliner XP is faced with purple moisture/mold/mildew resistant paper for protection against weather during installation.

I-Stud Code Report References:

ICC ES, Inc. Legacy Report 89-35.01
 ICC ES, Inc. Legacy Report 9525B
 ICBO ES, ER-3579

Note: In addition to National Gypsum systems, 1/2" Fire-Shield C, 5/8" Fire-Shield and 1" Fire-Shield Shaftliner panels are listed in Dietrich Industries ICC ES Legacy Report NER-506, Shaftwall and Stairwell Fire-Resistive (C-T stud) Assemblies.

TECHNICAL DATA

FUNCTION AND UTILITY

Loading Performance.

Although the cavity shaftwall systems are non-load-bearing, this System has been designed and tested to withstand positive and negative air pressure forces exerted by high-speed, high-rise elevators.

Fire Resistance. The cavity shaftwall systems have been fire tested and have achieved fire resistance ratings of 1 and 2 hours. All components are noncombustible. Refer to pages 19 and 20.

25 GA (.020" minimum steel thickness) J Track exceeded 2,000,000 lateral load oscillation cycles in a test conducted to duplicate the positive and negative pressures created as elevator cabs rise and descend in a shaft.

Sound Transmission. STC ratings of 40 to 51 have been achieved in tests conducted in accordance with ASTM E 90. Refer to pages 19 and 20.

LIMITATIONS

1. Nonload-bearing.
2. The cavity shaftwall systems should not be used where exposed to constant dampness or conditions under which free water can be formed.
3. This System should not be exposed to temperatures over 125° F for extended periods of time.
4. Where reference is made to nominal gauges, 25 gauge relates to minimum base steel of .020" and 20 gauge to .0329".

I-STUD SECTION PROPERTIES ABOUT X-X AXIS

A= Section Area, in.²

Y= Distance from neutral axis to extreme steel fiber, in.

I = Moment of Inertia, in.⁴

S= Section Modulus, in.³

Section properties based on steel without galvanizing.

Stud Size	Min. Base Steel	A	Y	I	S
2 1/2" (63.5 mm)	0.020"	0.133	1.366	0.151	0.110
2 1/2" (63.5 mm)	0.0329"	0.253	1.262	0.288	0.228
4" (102 mm)	0.020"	0.163	2.152	0.421	0.196
4" (102 mm)	0.0329"	0.307	2.016	0.822	0.408
6" (152 mm)	0.0329"	0.342	3.020	1.860	0.616

Above properties are in accordance with AISI "Specifications For the Design of Cold-Formed Steel Structural Members."

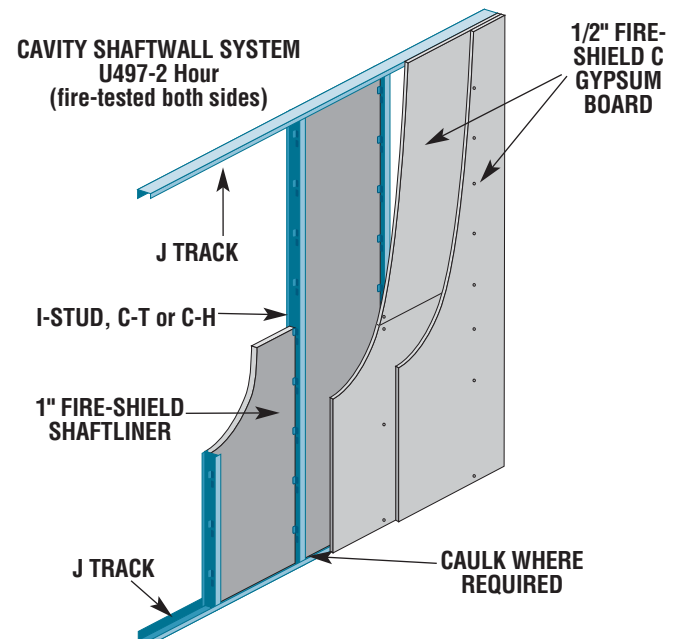

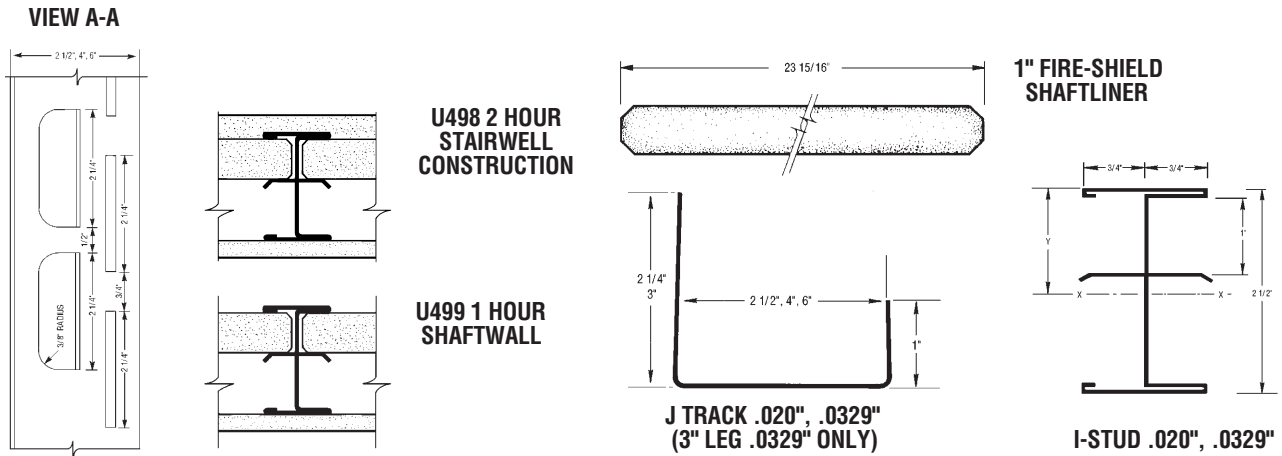

ALLOWABLE WALL HEIGHTS FOR 1-HOUR FIRE-RATED I-STUD ASSEMBLIES

Stud Size in. (mm)	Stud Spacing in. O.C. (mm)	Min. Steel Thickness in.	Allowable Deflection	Sustained Air Pressure Load PSF			
				5	7.5	10	15
2 1/2" (63.5 mm)	24" (610 mm)	0.020	L/120	13'- 4" (4060 mm)	11'- 7" (3531 mm)	10'- 1" (3073 mm)	8'- 3" (2515 mm)
			L/240	10'- 7" (3226 mm)	9'- 3" (2819 mm)	8'- 4" (2235 mm)	7'- 4" (2235 mm)
			L/360	9'- 3" (2819 mm)	8'- 1" (2464 mm)	7'- 4" (2235 mm)	6'- 5" (1956 mm)
2 1/2" (63.5 mm)	24" (610 mm)	0.0329	L/120	15'- 2" (4623 mm)	13'- 3" (4039 mm)	12'- 1" (3683 mm)	10'- 7" (3226 mm)
			L/240	12'- 1" (3683 mm)	10'- 7" (3226 mm)	9'- 7" (2921 mm)	8'- 4" (2540 mm)
			L/360	10'- 7" (3226 mm)	9'- 2" (2794 mm)	8'- 4" (2540 mm)	7'- 4" (2235 mm)
4" (102 mm)	24" (610 mm)	0.020	L/120	17'- 11" (5461 mm)	14'- 10" (4521 mm)	12'- 10" (3912 mm)	9'- 9" (2972 mm)
			L/240	14'- 3" (4343 mm)	12'- 5" (3785 mm)	11'- 4" (3454 mm)	9'- 5" (2870 mm)
			L/360	12'- 5" (3785 mm)	10'- 10" (3302 mm)	9'- 5" (2870 mm)	8'- 3" (2515 mm)
4" (102 mm)	24" (610 mm)	0.0329	L/120	20'- 0" (6096 mm)	18'- 2" (5537 mm)	16'- 6" (5029 mm)	14'- 3" (4343 mm)
			L/240	16'- 6" (5029 mm)	14'- 5" (4394 mm)	13'- 1" (3988 mm)	11'- 5" (3480 mm)
			L/360	14'- 5" (4394 mm)	12'- 7" (3835 mm)	11'- 5" (3480 mm)	9'- 4" (2845 mm)
6" (152 mm)	24" (610 mm)	0.0329	L/120	24'- 0" (7315 mm)	22'- 10" (6960 mm)	19'- 9" (6020 mm)	16'- 2" (4928 mm)
			L/240	20'- 11" (6375 mm)	18'- 4" (5588 mm)	16'- 8" (5080 mm)	14'- 6" (4420 mm)
			L/360	18'- 4" (5588 mm)	16'- 0" (4877 mm)	14'- 6" (4420 mm)	10'- 11" (3327 mm)

>Yield strength 40,000 psi
Limiting heights are based on transverse load tests (in accordance with ASTM E 72) and calculated utilizing the loads indicated.

ALLOWABLE WALL HEIGHTS FOR 2-HOUR FIRE-RATED I-STUD ASSEMBLIES UNLINED RETURN AIR SHAFTS

Stud Size in. (mm)	Stud Spacing in. O.C. (mm)	Min. Steel Thickness in.	Allowable Deflection	Sustained Air Pressure Load PSF			
				5	7.5	10	15
2 1/2" (63.5 mm)	24" (610 mm)	0.020	L/120	14'- 7" (4445 mm)	12'- 4" (3759 mm)	10'- 9" (3277 mm)	8'- 9" (2667 mm)
			L/240	11'- 7" (3531 mm)	10'- 1" (3073 mm)	9'- 2" (2794 mm)	8'- 0" (2438 mm)
			L/360	10'- 1" (3073 mm)	8'- 10" (2692 mm)	8'- 0" (2438 mm)	7'- 0" (2134 mm)
2 1/2" (63.5 mm)	24" (610 mm)	0.0329	L/120	17'- 9" (5410 mm)	15'- 6" (4724 mm)	14'- 1" (4293 mm)	12'- 4" (3759 mm)
			L/240	14'- 1" (4293 mm)	12'- 4" (3759 mm)	11'- 2" (3404 mm)	8'- 9" (3404 mm)
			L/360	12'- 4" (3759 mm)	9'- 8" (2946 mm)	8'- 9" (2667 mm)	7'- 8" (2337 mm)
4" (102 mm)	24" (610 mm)	0.020	L/120	19'- 10" (6045 mm)	16'- 3" (4953 mm)	14'- 0" (4267 mm)	10'- 2" (3099 mm)
			L/240	16'- 2" (4928 mm)	14'- 2" (4318 mm)	11'- 6" (3505 mm)	10'- 0" (3048 mm)
			L/360	14'- 2" (4318 mm)	11'- 0" (3353 mm)	10'- 0" (3048 mm)	8'- 9" (2667 mm)
4" (102 mm)	24" (610 mm)	0.0329	L/120	23'- 2" (7061 mm)	20'- 2" (6147 mm)	18'- 1" (5512 mm)	14'- 9" (4496 mm)
			L/240	18'- 4" (5588 mm)	16'- 1" (4902 mm)	14'- 7" (4445 mm)	11'- 1" (3378 mm)
			L/360	16'- 1" (4902 mm)	14'- 0" (4267 mm)	11'- 1" (3378 mm)	9'- 8" (2946 mm)
6" (152 mm)	24" (610 mm)	0.0329	L/120	28'- 0" (8534 mm)	23'- 11" (7290 mm)	20'- 9" (6325 mm)	16'- 11" (5156 mm)
			L/240	22'- 9" (6934 mm)	19'- 10" (6045 mm)	18'- 0" (5486 mm)	12'- 10" (3912 mm)
			L/360	19'- 10" (6045 mm)	17'- 4" (5283 mm)	12'- 10" (3912 mm)	11'- 2" (3404 mm)

>Yield strength 40,000 psi
Limiting heights are based on transverse load tests (in accordance with ASTM E 72) and calculated utilizing the loads indicated.

09 21 16.23

ALLOWABLE WALL HEIGHTS FOR 2-HOUR FIRE-RATED I-STUD ASSEMBLIES STAIRWELLS

Stud Size in. (mm)	Stud Spacing in. O.C. (mm)	Min. Steel Thickness in.	Allowable Deflection	Sustained Air Pressure Load PSF			
				5	7.5	10	15
2 1/2" (63.5 mm)	24" (610 mm)	0.020	L/120	13'- 11" (4242 mm)	12'- 2" (3708 mm)	11'- 0" (3353 mm)	9'- 8" (2946 mm)
			L/240	11'- 0" (3353 mm)	9'- 8" (2946 mm)	8'- 9" (3404 mm)	7'- 8" (2337 mm)
			L/360	8'- 9" (2946 mm)	8'- 5" (2565 mm)	7'- 8" (2337 mm)	6'- 8" (2032 mm)
2 1/2" (63.5 mm)	24" (610 mm)	0.0329	L/120	16'- 7" (5055 mm)	14'- 6" (4420 mm)	13'- 2" (4013 mm)	11'- 6" (3505 mm)
			L/240	13'- 2" (4013 mm)	11'- 6" (3505 mm)	9'- 10" (2897 mm)	8'- 7" (2616 mm)
			L/360	11'- 6" (3505 mm)	10'- 0" (3048 mm)	8'- 7" (2616 mm)	7'- 6" (2286 mm)
4" (102 mm)	24" (610 mm)	0.020	L/120	20'- 2" (6147 mm)	17'- 8" (5385 mm)	16'- 0" (4877 mm)	11'- 11" (3632 mm)
			L/240	16'- 0" (4877 mm)	11'- 11" (3632 mm)	10'- 10" (3302 mm)	9'- 5" (2870 mm)
			L/360	11'- 11" (3632 mm)	10'- 6" (3175 mm)	9'- 5" (2870 mm)	8'- 3" (2515 mm)
4" (102 mm)	24" (610 mm)	0.0329	L/120	22'- 3" (6782 mm)	19'- 6" (5944 mm)	17'- 8" (5385 mm)	15'- 6" (4724 mm)
			L/240	17'- 8" (5385 mm)	15'- 6" (4724 mm)	14'- 1" (4293 mm)	10'- 8" (3251 mm)
			L/360	15'- 6" (4724 mm)	11'- 9" (3581 mm)	10'- 8" (3251 mm)	9'- 4" (2845 mm)
6" (152 mm)	24" (610 mm)	0.0329	L/120	28'- 0" (8534 mm)	24'- 10" (7569 mm)	22'- 7" (6883 mm)	19'- 9" (6020 mm)
			L/240	22'- 7" (6883 mm)	19'- 9" (6020 mm)	17'- 11" (5461 mm)	12'- 3" (3734 mm)
			L/360	19'- 9" (6020 mm)	13'- 6" (4115 mm)	12'- 3" (3734 mm)	10'- 9" (3277 mm)

>Yield strength 40,000 psi
Limiting heights are based on transverse load tests (in accordance with ASTM E 72) and calculated utilizing the loads indicated.

ALLOWABLE WALL HEIGHTS FOR 2-HOUR FIRE-RATED I-STUD ASSEMBLIES

Stud Size in. (mm)	Stud Spacing in. O.C. (mm)	Min. Steel Thickness-in.	Allowable Deflection	Intermittent Air Pressure Load PSF			
				5	7.5	10	15
2 1/2" (63.5 mm)	24 (610 mm)	0.020	L/120	15'- 3" (4648 mm)	12'- 6" (3810 mm)	10'- 9" (3276 mm)	8'-10" (2692 mm)
			L/240	12'- 6" (3810 mm)	11'- 0" (3352 mm)	10'- 0" (3048 mm)	8'- 9" (2667 mm)
			L/360	11'- 0" (3352 mm)	9'- 6" (2895 mm)	8'- 8" (2641 mm)	7'- 7" (2311 mm)
2 1/2" (63.5 mm)	24 (610 mm)	0.0329	L/120	17'-10" (5435 mm)	15'- 8" (4775 mm)	14'- 2" (4318 mm)	*12'- 5" (3784 mm)
			L/240	14'- 2" (4318 mm)	12'- 5" (3784 mm)	11'- 4" (3454 mm)	9'-10" (2997 mm)
			L/360	12'- 5" (3784 mm)	10'-11" (3327 mm)	9'-10" (2997 mm)	8'- 7" (2616 mm)
4 (102 mm)	24 (610 mm)	0.020	L/120	20'- 4" (6197 mm)	16'- 8" (5080 mm)	*14'- 5" (4394 mm)	*11'-10" (3606 mm)
			L/240	16'- 1" (4902 mm)	14'- 1" (4292 mm)	12'-10" (3911 mm)	*11'- 2" (3403 mm)
			L/360	14'- 1" (4292 mm)	12'- 4" (3759 mm)	11'- 2" (3403 mm)	* 9'-10" (2997 mm)
4 (102 mm)	24 (610 mm)	0.0329	L/120	21'-10" (4114 mm)	*19'- 1" (5816 mm)	*17'- 4" (5283 mm)	*15'- 1" (4597 mm)
			L/240	17'- 4" (5283 mm)	15'- 1" (4597 mm)	13'-10" (4216 mm)	*12'- 0" (3657 mm)
			L/360	15'- 1" (4597 mm)	13'- 2" (4013 mm)	12'- 0" (3657 mm)	*10'- 6" (3200 mm)
6 (152 mm)	24 (610 mm)	0.0329	L/120	25'- 4" (7721 mm)	*22'- 1" (6731 mm)	*20'- 1" (6121 mm)	*17'- 6" (5334 mm)
			L/240	20'- 1" (6121 mm)	*17'- 6" (5334 mm)	*15'-11" (4851 mm)	*13'-11" (4241 mm)
			L/360	17'- 6" (5334 mm)	15'- 4" (4673 mm)	13'-11" (4241 mm)	*12'- 2" (3708 mm)

f Limited by bending stress
v Limited by end reaction relating to stud or track
* 20 gauge track required

> Yield strength 40,000 psi
> Unless noted, heights are limited by deflection.
> For heights limited by bending stress, allowable bending stresses have been increased by 33.33% for intermittent loading.
> Heights limited by deflection are based on transverse load tests (in accordance with ASTM E 72) and calculated utilizing the loads indicated.

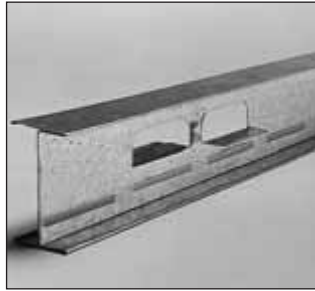

SHAFTWALL STUD
Used with J Track for framing Cavity Shaftwalls. Tabs retain 1" shaftliner. Galvanized steel.

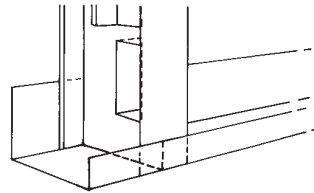

J TRACK
2 1/4" Leg.
Used with I-Stud for framing Cavity Shaftwalls. Galvanized steel.

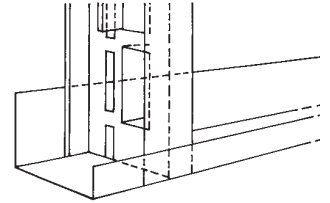

DETAILS

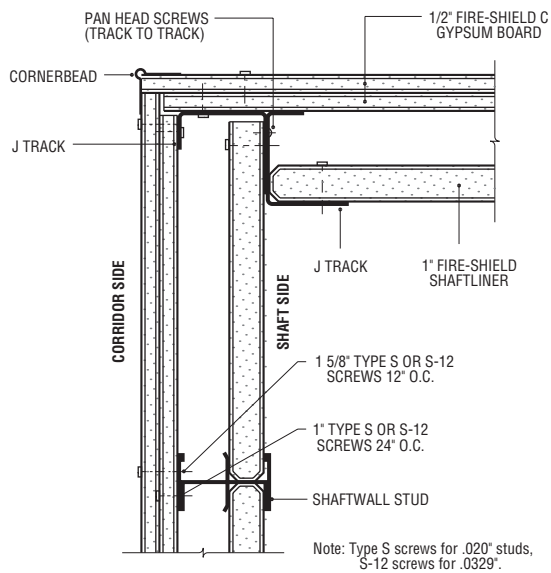

OUTSIDE CORNER
09260C
Scale: 2 1/4" = 1'-0"

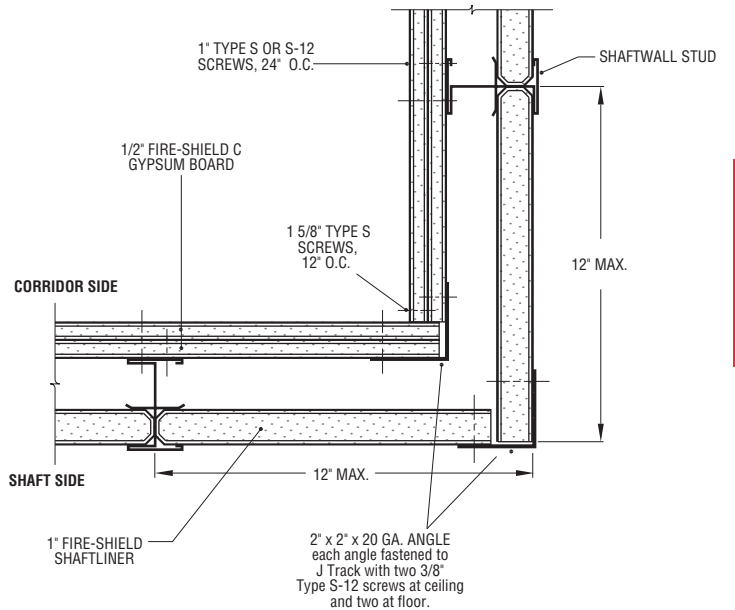

INSIDE CORNER
09260D
Scale: 2 1/4" = 1'-0"

09 21 16.23

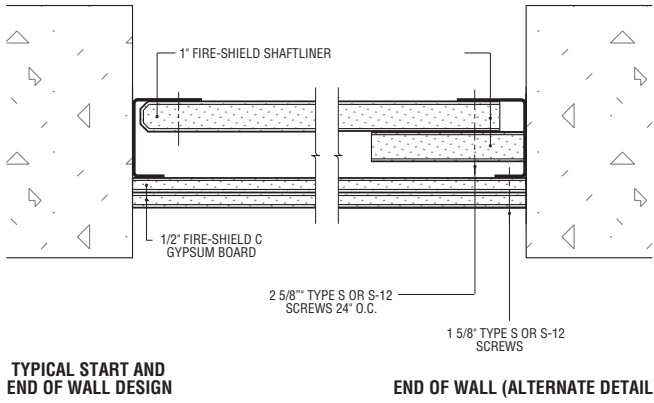

**TYPICAL START AND
END OF WALL DESIGN**

09260B
Scale: 2 1/4" = 1'-0"

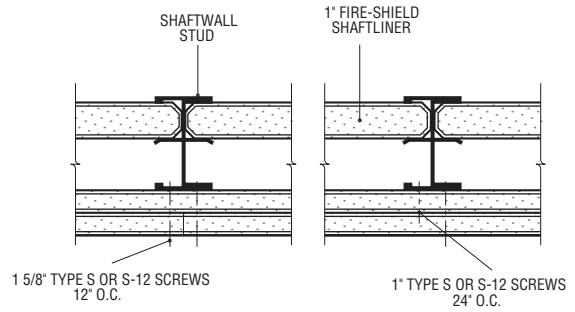

TYPICAL SECTION

09260A
Scale: 2 1/4" = 1'-0"

7' Elevator Door Frames

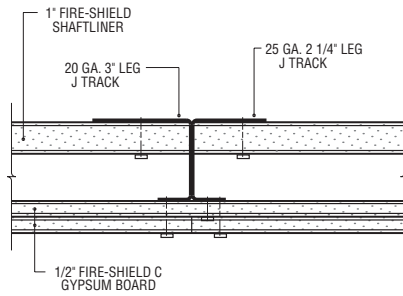

**SHAFTWALL J TRACK FRAMING ABOVE 7'-0"
ELEVATOR DOOR
(Section C-C)**

09260G
Scale: 2 1/4" = 1'-0"

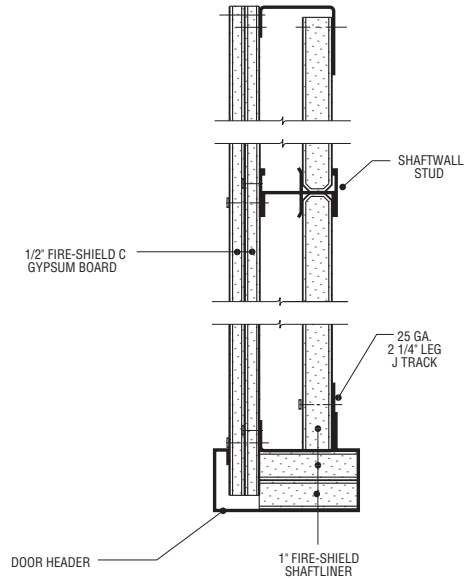

**SHAFTWALL ELEVATOR DOOR HEAD
(Section B-B)**

09260H
Scale: 2 1/4" = 1'-0"

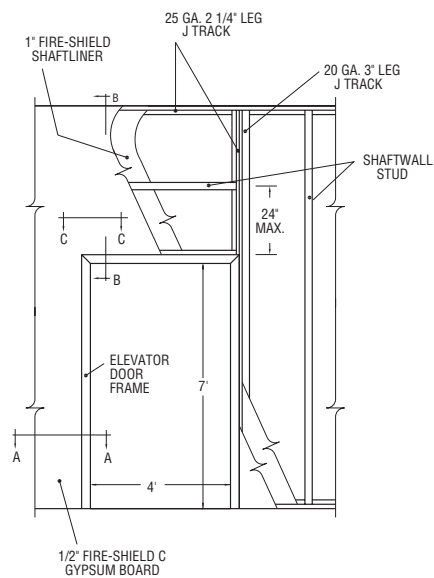

SHAFTWALL FRAMING FOR ELEVATOR DOOR UP TO 7'-0"

09260E
Scale: 1/4" = 1'-0"

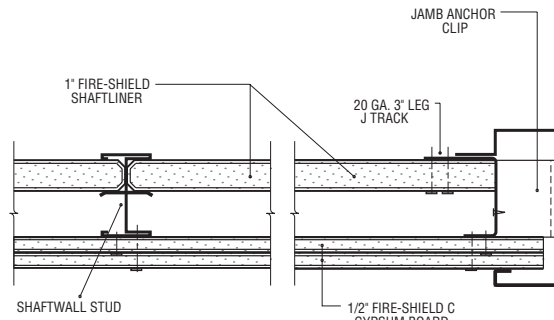

**SHAFTWALL 7'-0" ELEVATOR DOOR JAMB
(Section A-A)**

09260F
Scale: 2 1/4" = 1'-0"

Elevator Door Frames Over 7'

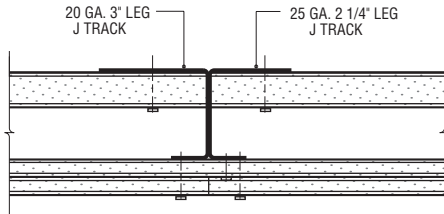

SHAFTWALL J TRACK FRAMING ABOVE ELEVATOR DOOR (Section F-F)

09260K
Scale: 2 1/4" = 1'-0"

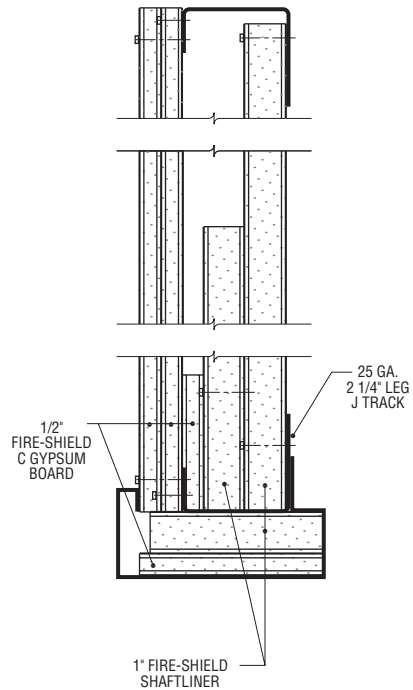

SHAFTWALL ELEVATOR DOOR HEAD (Section E-E)

09260L
Scale: 3" = 1'-0"

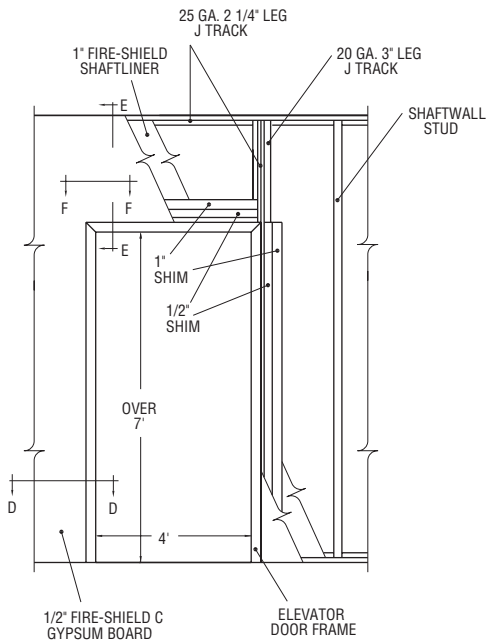

SHAFTWALL FRAMING FOR ELEVATOR DOOR OVER 7'-0"

09260I
Scale: 1/4" = 1'-0"

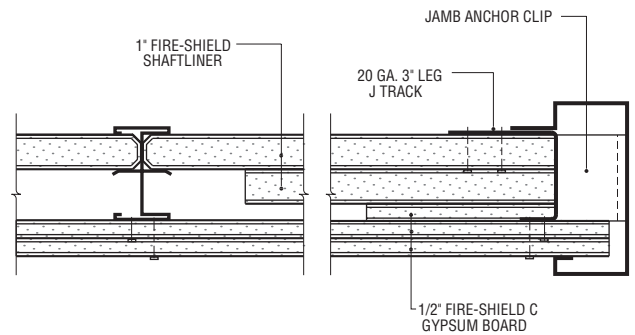

SHAFTWALL ELEVATOR DOOR JAMB (Section D-D)

09260J
Scale: 2 1/4" = 1'-0"

09 21 16.23

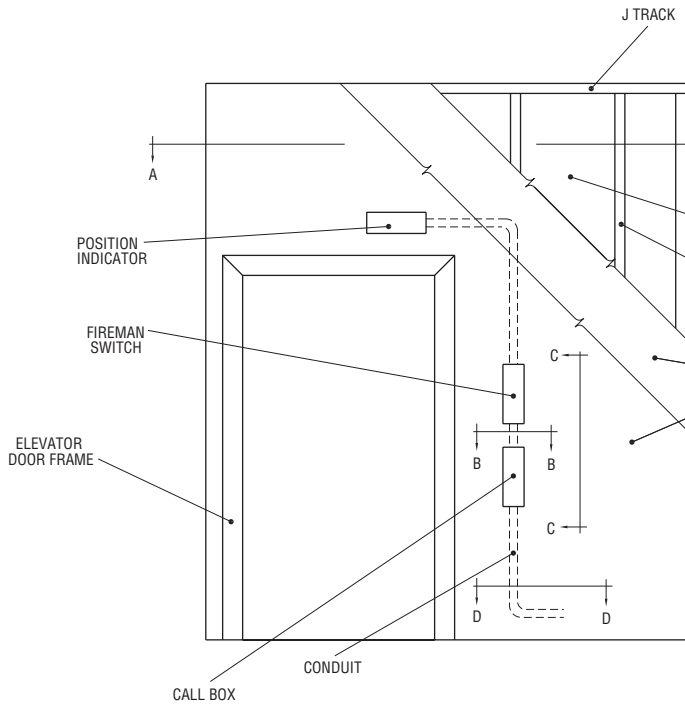

SHAFTWALL ELEVATOR ELECTRICAL CONTROL LAYOUT

09260Z
Scale: 1/4" = 1'-0"

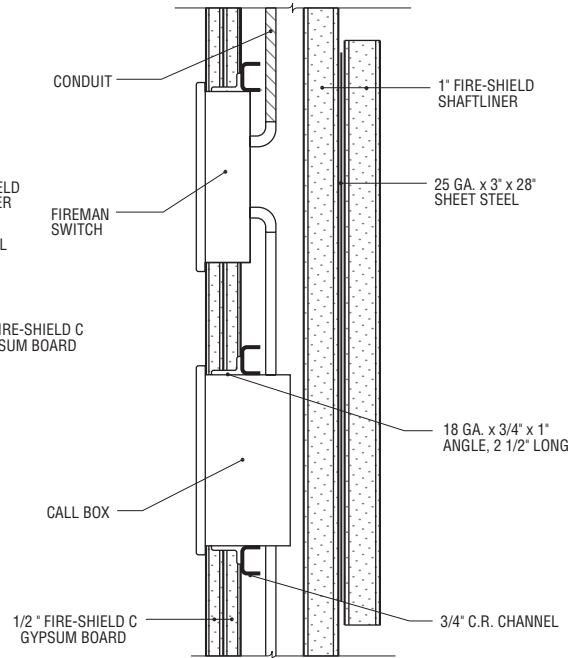

**SHAFTWALL FIREMAN SWITCH AND CALL BOX
(Section CC)**

09260AA
Scale: 2 1/4" = 1'-0"

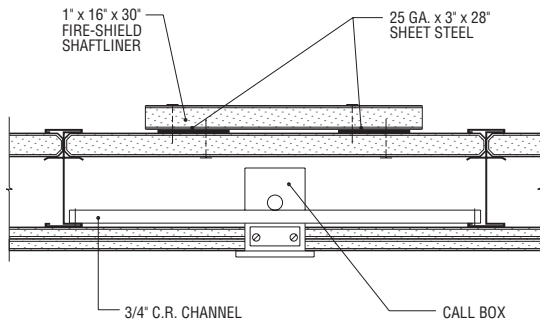

**SHAFTWALL CALL BOX
(Section BB)**

09260BB
Scale: 1 1/2" = 1'-0"

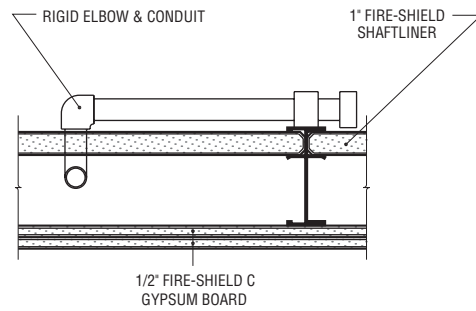

**SHAFTWALL WITH CONDUIT
(Section DD)**

09260CC
Scale: 1 1/2" = 1'-0"

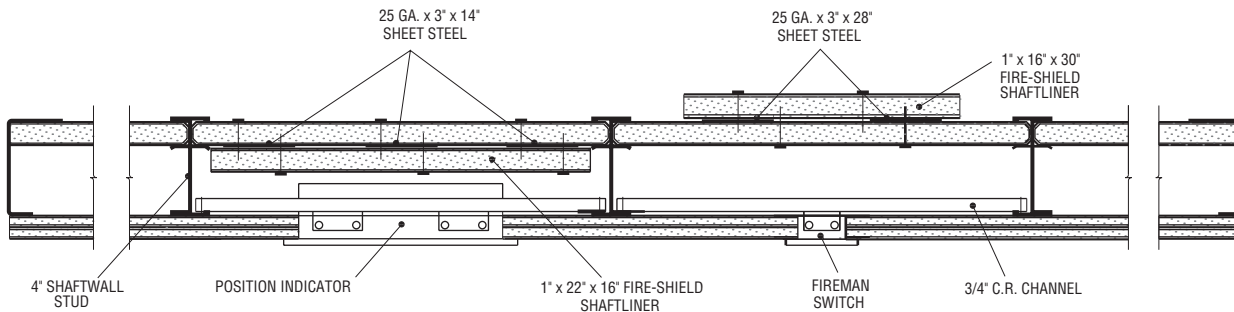

**SHAFTWALL FIREMAN SWITCH AND INDICATOR BOX
(Section AA)**

09260DD
Scale: 1 1/2" = 1'-0"

NOTE: These assemblies tested Factory Mutual
Design WP 621 and Factory Mutual WP 612

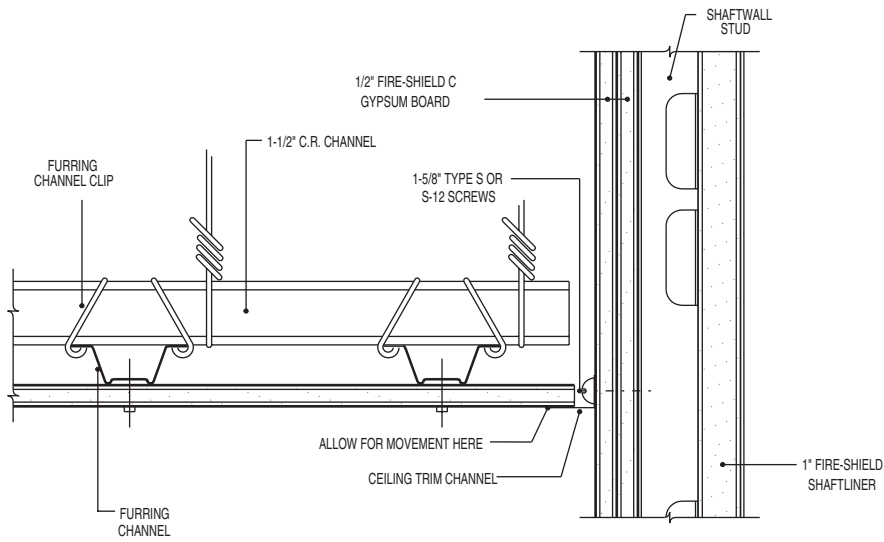

SHAFTWALL AT SUSPENDED CEILING

(UNRESTRAINED)

09260M

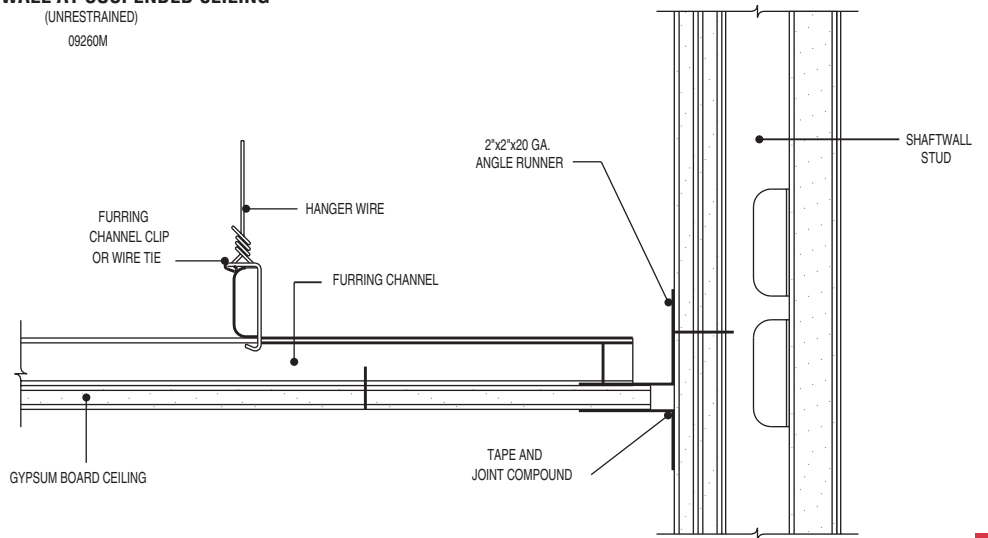

SHAFTWALL AT SUSPENDED CEILING

(RESTRAINED)

09260N

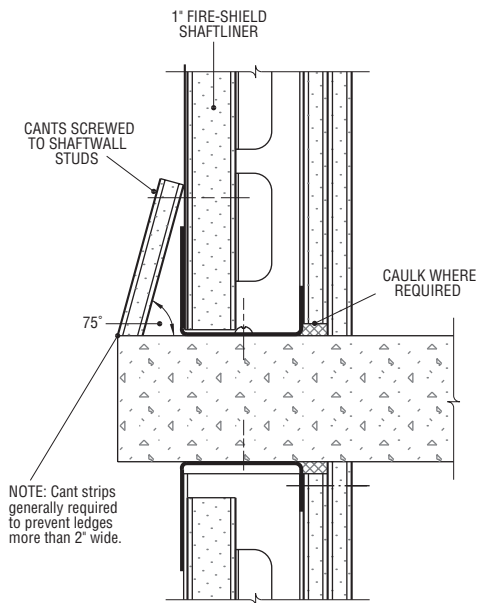

SHAFT CANTS

09260P

Scale: 3" = 1'-0"

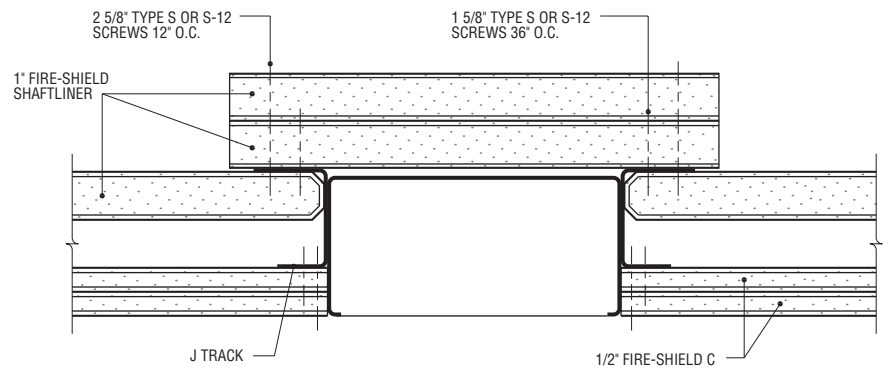

MAIL CHUTE

092600

Scale: 3" = 1'-0"

09 21 16.23

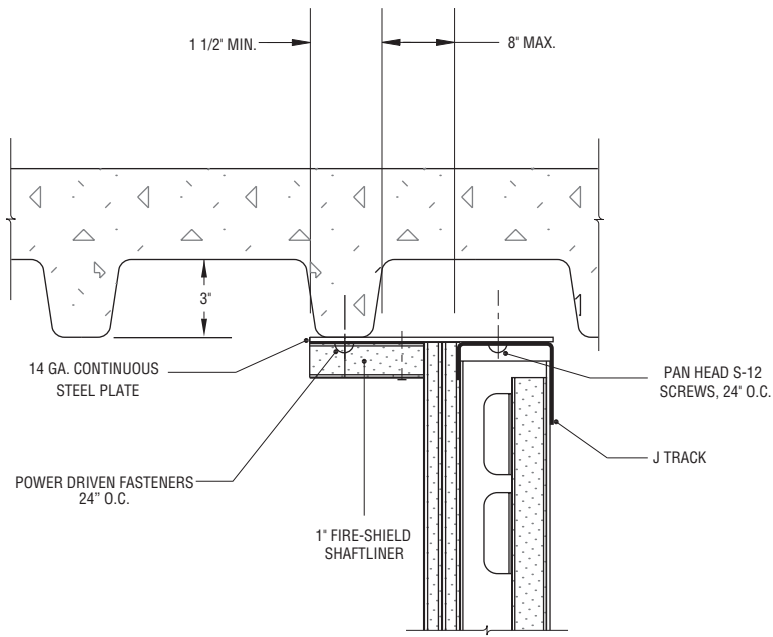

**STUD CAVITY WALL
PARALLEL TO DECK VALLEYS**

09260Q
Scale: 2 1/4" = 1'-0"

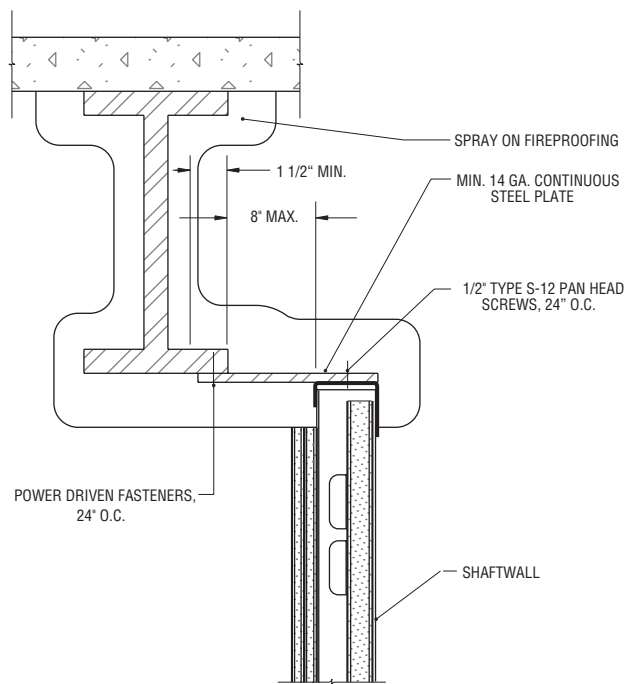

**SHAFTWALL OFFSET
FROM STEEL BEAM**

09260R
Scale: 1 1/2" = 1'-0"

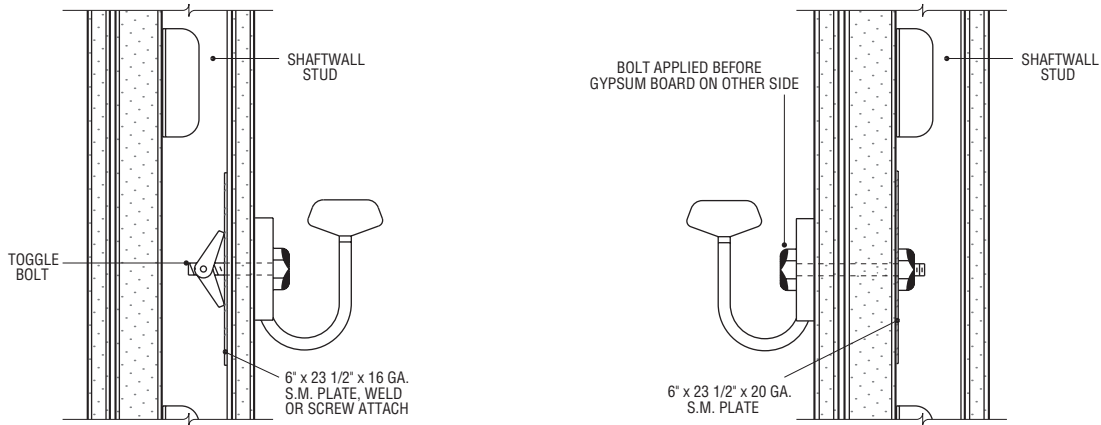

HANDRAIL SUPPORT DETAILS

NOTE: HANDRAIL BRACKET SHALL HAVE A MINIMUM AREA OF 3.25 SQ. IN. AND MINIMUM WIDTH ALONG BOTTOM EDGE OF 1 3/8" IF RECTANGULAR, AND A MINIMUM DIAMETER OF 2 3/8" IF ROUND IN ORDER TO COMPLY WITH 200 POUND PULLOUT AND/OR COMPRESSION TESTS (NFPA 101-1985 LIFE SAFETY CODE - BRACKETS).

09260U
Scale: 3" = 1'-0"

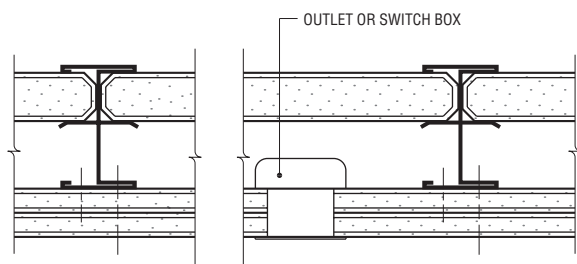

CROSS SECTION
09260V
Scale: 3" = 1'-0"

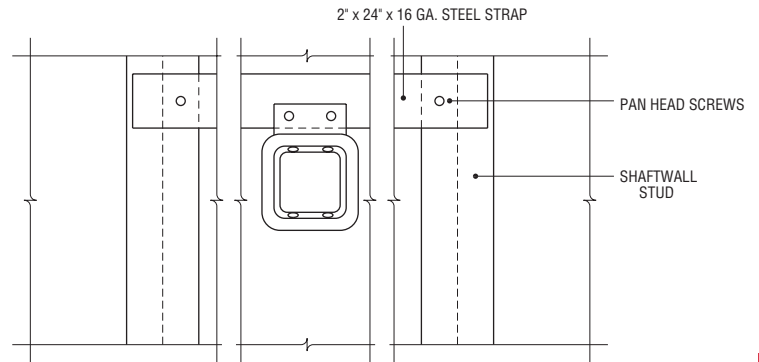

ELECTRICAL OUTLET SUPPORT
09260W
Scale: 3" = 1'-0"

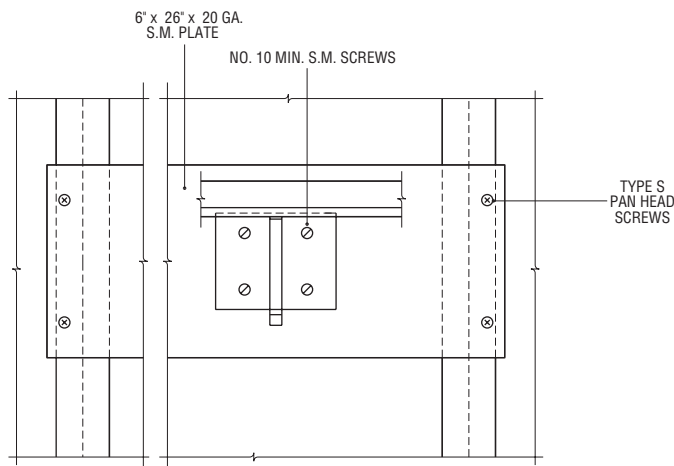

HANDRAIL SUPPORT DETAILS
09260S
Scale: 2" = 1'-0"

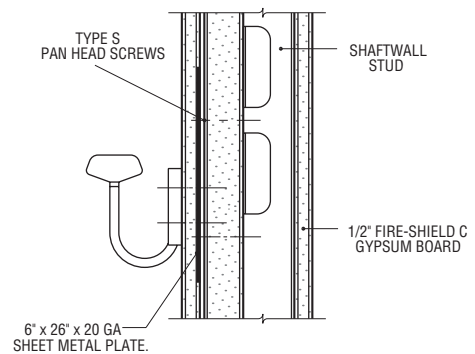

HANDRAIL SUPPORT DETAILS
09260T
Scale: 2 1/4" = 1'-0"

09 21 16.23

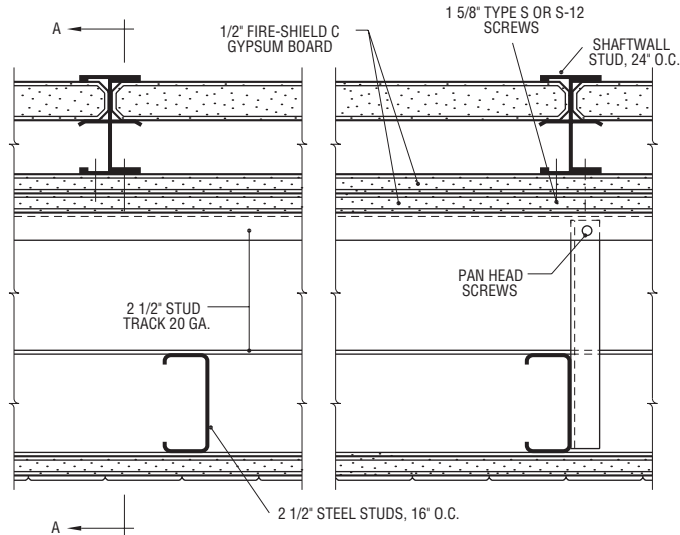

CHASE WALL
09260EE
Scale: 3" = 1'-0"

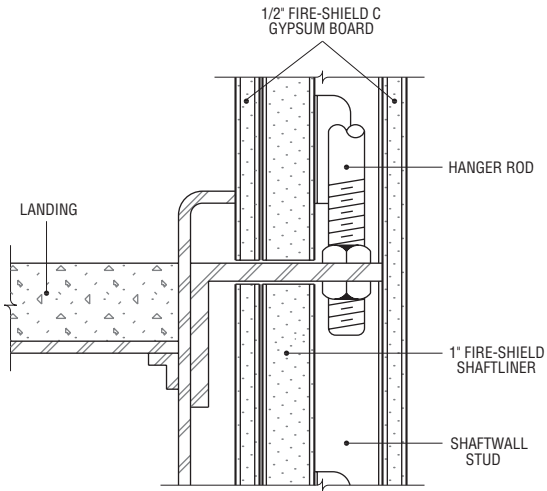

STAIR HANGER ROD
09260X
Scale: 3" = 1'-0"

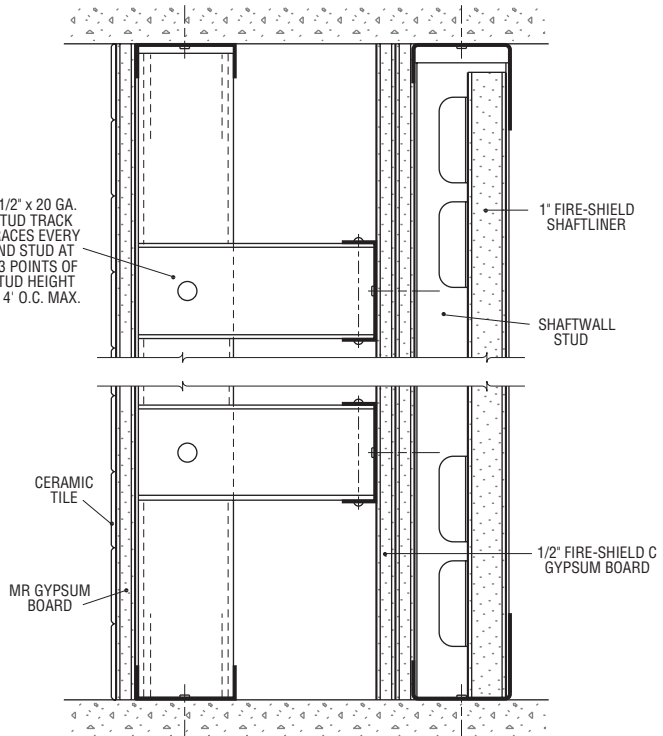

SHAFTWALL CHASE WALL (SECTION A-A)
09260FF
Scale: 3" = 1'-0"

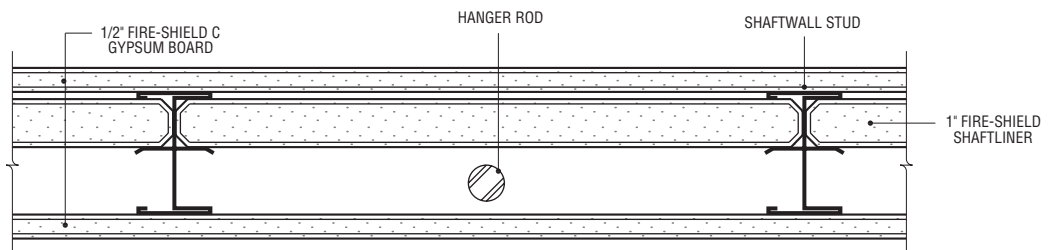

STAIRWELL STAIR HANGER ROD
09260Y
Scale: 3" = 1'-0"

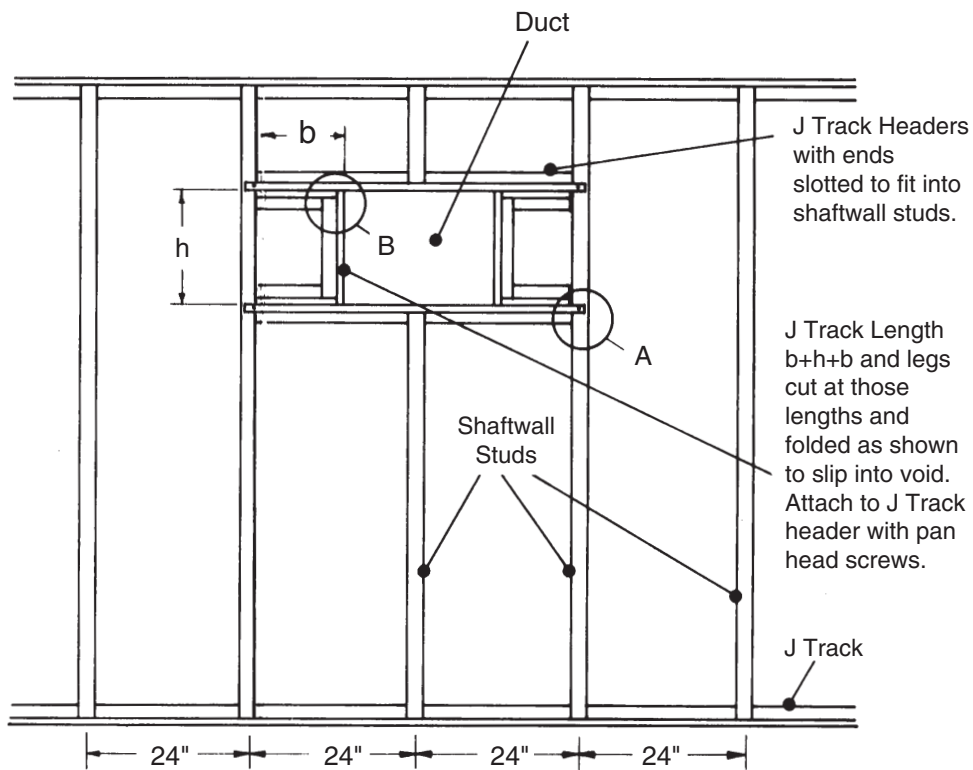

**TYPICAL DUCT OPENING
RECOMMENDED FRAMING**

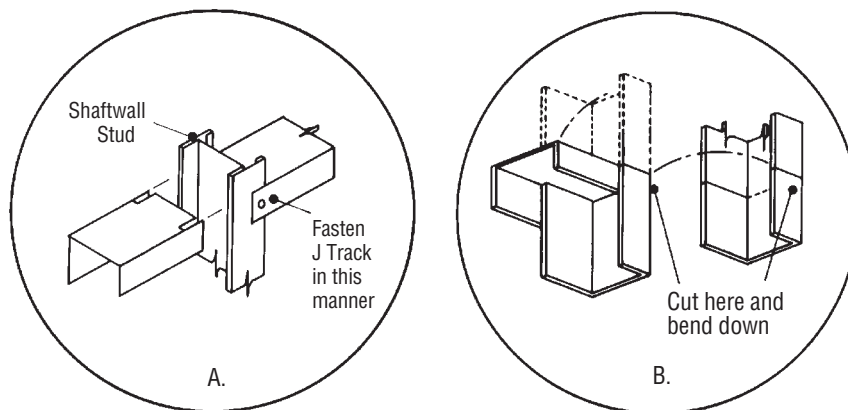

09 21 16.23

RECOMMENDATIONS

Shaftliner panels should be handled with care to prevent fracturing or deformation of edges.

FRAMING AND SHAFTLINER CAVITY SHAFTWALL

1. Locate and lay out partition floor and ceiling lines to ensure plumb partition.
2. Insure accurate stud spacing to maintain gypsum board face layer module.
3. Position top and bottom J Track with long leg toward the shaft along ceiling, floor and vertically at column and/or wall where erection of shaftwall will begin. Attach with power driven fasteners 24" o.c. max.
4. Frame all openings cut into partitions for ducts, etc. with J Track as shown in accompanying details to protect cut gypsum core edges and to provide resistance to bending and other stresses.
5. Cut shaftliner panels 1" less than ceiling height and install first by placing outside vertical edge against long leg of vertical track, plumb and attach with Type S 1 5/8" Screws 24" o.c.
6. Place studs within flanges of floor and ceiling track and rotate into place. Slide stud tabs/flange snugly over edge of shaftliner previously installed.
7. Install next shaftliner panel between tabs/flange of studs. Continue in this manner until end of partition run. Occasionally check spacing of studs to maintain 24" module.
8. At end of run, cut vertical J Track at least 2" short of partition height. Cut shaftliner 1/4" less than remaining width of partition and 2" short of full height. Lay piece of shaftliner 2" wide x length of opening in floor track as support for last shaftliner panel. Fit cut edge of shaftliner into vertical track and, holding shaftliner and track together, slide paper

bound edge of shaftliner into stud. Align last panel and fasten the vertical track with appropriate fasteners 24" o.c. max. Fasten shaftliner to vertical track with 1 5/8" Type S or S-12 Screws 24" o.c. See drawing on page 126 for alternate detail.

9. Locate shaftwall horizontal end joints within the upper and lower third points of wall. Stagger joints in adjacent panels to avoid continuous horizontal joint. Shaftliner horizontal end joints do not require taping, back blocking or framing. When using I-Studs the shaftliner panels shall be of sufficient length to engage a minimum of two I-Stub tabs along the edge.

GYPSUM BOARD

Apply first layer of 1/2" Fire-Shield C (5/8" Fire-Shield) Gypsum Board horizontally to face of studs with screws spaced 24" o.c. Apply second layer vertically with screws spaced 12" o.c. (Use 1" Type S Screws on first layer, 1 5/8" Type S Screws on second layer for 25 gauge nominal framing.) (Use 1" Type S-12 Screws on first layer, 1 5/8" Type S-12 Screws on second layer for 20 gauge or heavier framing.) Stagger all vertical and horizontal joints. For proper joint treatment, maintain uniform room temperature between 50°F and 70°F during cold weather. Treat joints of face layer with tape and joint compound.

CAULKING

Caulk Cavity Shaftwall system with acoustical sealant wherever the wall is enclosing shafts where positive or negative air pressure exists. Caulk perimeter of wall and at any other place where voids create the possibility of moving air causing dust accumulation, noise or smoke leakage. Caulking shall be done in compliance with details specified by the architect/designer.

AIR SHAFTS

The System is not designed to serve as an unlined air supply duct. Caulking is recommended at perimeters and penetrations wherever the I-Stub System is used to enclose elevators or other shafts where positive or negative pressures will exist. The contractor installing this System shall caulk in compliance with details specified by the architect/designer. Proper caulking will seal perimeters and penetrations to minimize air noises and dust associated with air movement.

FRAMING FOR OPENINGS

Frame doors and duct openings with J Track. Use adequate structural support for openings over 48" wide. For openings up to 48" wide, use vertical J Track on either side of openings. For head and sill of openings, place J Track horizontally across openings. Cut J Track about 12" longer than openings. Then cut flanges and fold back to nest over vertical J Track and fasten webs or flanges with two 3/8" Type S or 1/2" Type S-12 Pan Head Screws per connection. When nesting J Track to J Track, cut off short flange of horizontal J Track so it will fit over vertical J Track.

CALL BOXES AND POSITION INDICATORS

Protect call boxes, position indicators and fireman's switches as shown in drawings on page 130.

CHASES

When possible, locate all vertical rise, conduit, stair hangers, etc., within wall cavity. If the cavity in the 2 1/2" stud wall is not of sufficient width, the 4" or 6" studs can be used for chases or erect chase walls as shown on page 134.

ELEVATOR DOORS

Elevator door frames must be braced and supported independently of the

shaftwall. However, shaftwall must be tied into elevator door frames by being attached to jamb and anchor clips with pan head screws. The 3" leg, nominal 20 gauge J Track shall be used at the juncture of the elevator door frame and the Cavity Shaftwall System. See drawings on pages 128 and 129 for details.

Door frames (other than elevator door frames) should be formed from not less than 18 gauge steel, shop primed, with throat openings accurately formed to the nominal wall thickness plus 3/32". Frames must have trim returns not less than 7/16" in width to bear flush against the gypsum board surface. Floor anchor plates should be 14 gauge (min.) steel, firmly welded to frames and designed with not less than two anchor holes 3" o.c. minimum to prevent frame rotation. Anchor plates should be securely fastened to the floor with power driven fasteners having minimum dimensions of 3/16" diameter and 3/4" length. The type and size of fastener is dependent on job conditions, type of concrete or steel framing, etc., and must be sufficient to provide rigid, continuous anchorage to the frames. Jamb anchor clips should be formed from 18 gauge (min.) steel, and welded to jambs to provide adequate anchorage to jamb framing as shown on details. Elevator door frames must be fastened to and supported by the building structure, separately framed and independent of the partition. They shall be securely anchored to the sills and to the building structure or to the track supports. Anchors or fastenings to suit the wall construction are required and shall be not more than 2" apart. See details on pages 128 and 129 for connection of partition and elevator door frames.