

distinct designs

FLEXCO® offers one of today's most extensive lines of PVC free rubber stair treads. Our system of rubber stair treads, risers, stringers and landing tiles was developed to bring style, dependability and efficiency together. So design outside the box. Choose from our Distinct Designs colors to give your project a fresh look. May contribute to LEED® CI and NC credits MR 4, MR 5 and MR 6.

features and benefits

- > Natural resistance to bacteria and fungi when tested in accordance with ASTM G 21.
- > PVC free rubber treads meet ASTM F 2169, Type TS.
- > Exceeds ADA recommendations for slip resistance on flat surfaces.
- > Enhanced performance of rubber treads with our metal-reinforced nose is backed by a 25-year warranty.
- > Compression molded into a dense, homogeneous construction with color that extends through the entire thickness.
- > Colors coordinate with wall base, accessories and tile products in our FlexTones® color matching system.
- > Ribbed inserts or grit strips can be inserted for the visually impaired or extra traction.
- > Meets Class 1 Fire Rating.
- > Available in Class A formulation upon request.
- > 16/86 Multiperformance Tile & Tread Adhesive contains an antimicrobial agent for added protection against mold and bacteria.

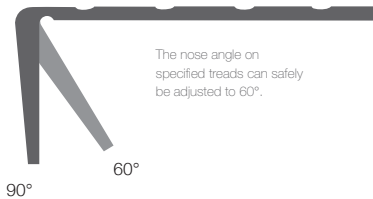

The nose angle on specified treads can safely be adjusted to 60°.

Treads with an adjustable nose help speed installation and meet ADA recommendations.

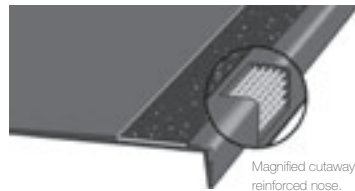

Magnified cutaway to show metal-reinforced nose.

Rubber treads with our exclusive metal-reinforced nose enhance performance and durability.

25-year warranty.



Continuous-length treads up to 9' are available in types 550, 585, 650 SQ Nose, 685, 701, 776, 1701 and 1776 for very wide stairs.





distinct designs rubber stair treads

Heavy Duty Radial® II Order Prefix 701 & 776

Gauge	3/16" at nose
Depth	12"
Lengths	36", 42", 48", 54", 60", 72", 84", 96", 108"
Nose	Square, adjustable to 60°
Pieces /Ctn	6 (72" or less), 4 (84" and up)
Weight /Lin Ft (lb)	2
Matching Profile	Radial II (RGT)

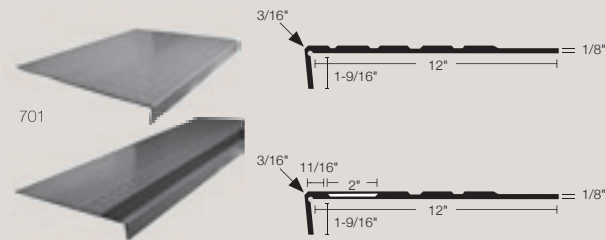

776 Visually Impaired Contrast
2" strip

Heavy Duty Square² Order Prefix 800 & 875

Gauge	1/4" at nose
Depth	12-1/4"
Lengths	36", 42", 48", 54", 60", 72"
Nose	Square
Pieces /Ctn	6 (72" or less)
Weight /Lin Ft (lb)	2.8
Matching Profile	Square ² (SQ)

Exclusive metal-reinforced nose included.

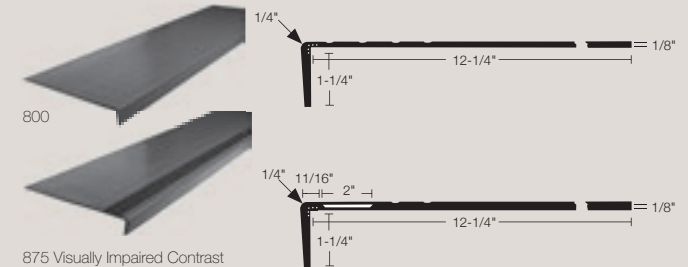

875 Visually Impaired Contrast
2" strip

Extra Heavy Duty Radial® Order Prefix 500 & 575

Gauge	5/16" at nose
Depth	12"
Lengths	36", 42", 48", 54", 60", 72"
Nose	Square
Pieces /Ctn	6
Weight /Lin Ft (lb)	2.8
Matching Profile	Radial high profile (RBT)

Exclusive metal-reinforced nose included.

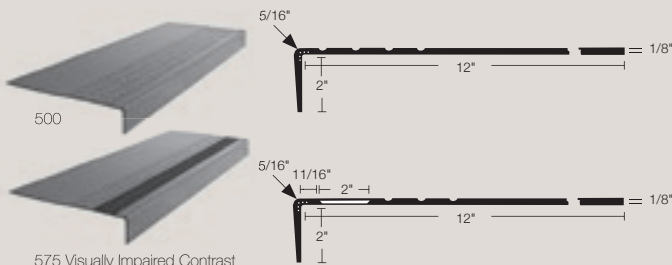

575 Visually Impaired Contrast
2" strip

Heavy Duty Radial® Order Prefix 550 & 585

Gauge	3/16" at nose
Depth	12"
Lengths	36", 42", 48", 54", 60", 72", 84", 96", 108"
Nose	Square, adjustable to 60°
Pieces /Ctn	6 (72" or less), 4 (84" and up)
Weight /Lin Ft (lb)	2.4
Matching Profile	Radial high profile (RBT)

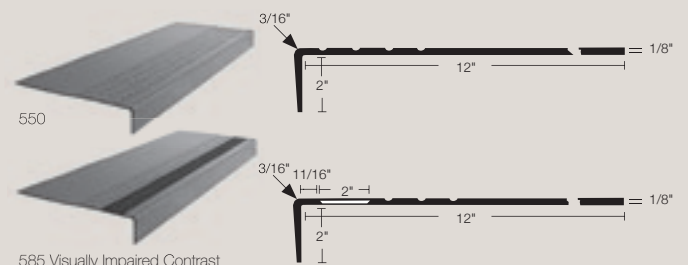

585 Visually Impaired Contrast
2" strip

Heavy Duty Radial® II One-Piece Tread with Riser Order Prefix 1701 & 1776

Gauge	1/4" at nose
Depth	20-1/2"
Lengths	36", 42", 48", 54", 60", 72", 84", 96", 108"
Nose	Square, adjustable to 60°
Pieces /Ctn	6 (48" or less), 4 (54" and up)
Weight /Lin Ft (lb)	2.5
Matching Profile	Radial II (RGT)

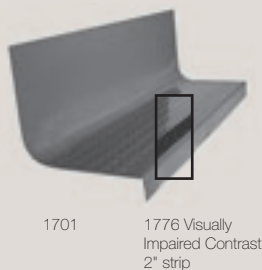

1701 1776 Visually Impaired Contrast
2" strip

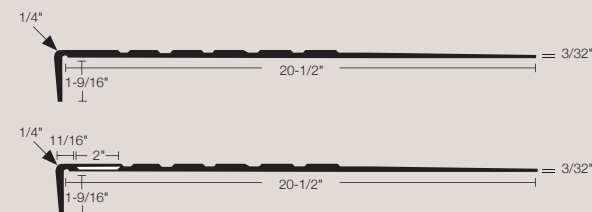

Heavy Duty Extended Radial® II Order Prefix 701E & 776E

Gauge	1/4" at nose
Depth	15"
Lengths	36", 42", 48", 54", 60", 72"
Nose	Square, adjustable to 60°
Pieces /Ctn	6
Weight /Lin Ft (lb)	2
Matching Profile	Radial II (RGT)

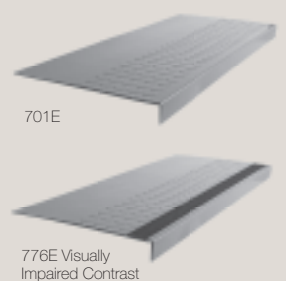

776E Visually Impaired Contrast

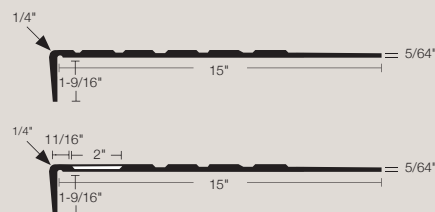

- > All stair treads must be installed with FLEXCO® 16/86 Multipurpose Tile & Tread Adhesive, FlexTape or 77 Solvent-Free Epoxy Adhesive. FLEXCO® 36 Epoxy Caulking Compound must be applied to nose of the tread. Adjustable nose portion should be secured with contact adhesive or FlexTape according to FLEXCO® instructions.
- > 25-year warranty on treads with our metal-reinforced nose applies to treads 500, 575, 600, 675, 800, 875.
- > Use prefix S when ordering SpexTones®.

Heavy Duty Smooth
Order Prefix 120, 130 & 170

Gauge 3/16" at nose
Depth 12-1/4"
Lengths 36", 42", 48", 54", 60", 72"
Nose Square
Pieces /Ctn 10
Weight /Lin Ft (lb) 1.5
Matching Profile Smooth Tile or Sheet and Diamond Landing
Grit strips for 130 in black only.

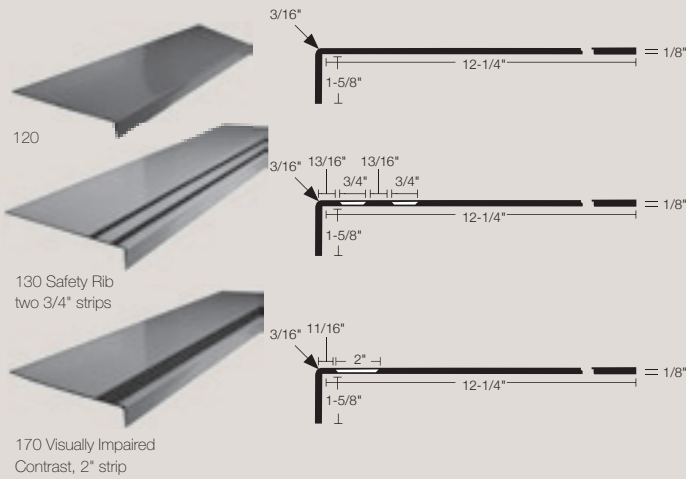

Extra Heavy Duty Diamond
Order Prefix 600 & 675

Gauge 5/16" at nose
Depth 12"
Lengths 36", 42", 48", 54", 60", 72"
Nose Square
Pieces /Ctn 6
Weight /Lin Ft (lb) 600 2.8
675 2.4
Matching Profile Smooth Tile or Sheet and Diamond Landing
Exclusive metal-reinforced nose included.

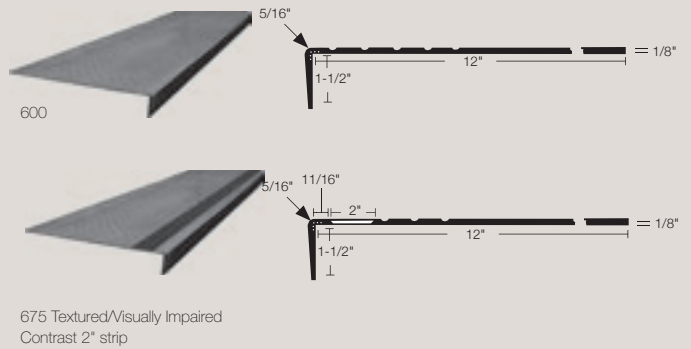

Heavy Duty Diamond
Order Prefix 650 and 685

Gauge Square 1/4" at nose and round 7/64" at nose.
Depth 12"
Lengths 36", 42", 48", 54", 60", 72", 84", 96", 108"
Nose Round Nose only up to 72" in length
Square and Round
Pieces /Ctn 6 (72" or less)
4 (84" and up)
Weight /Lin Ft (lb) 2.25
Matching Profile Smooth Tile or Sheet and Diamond Landing

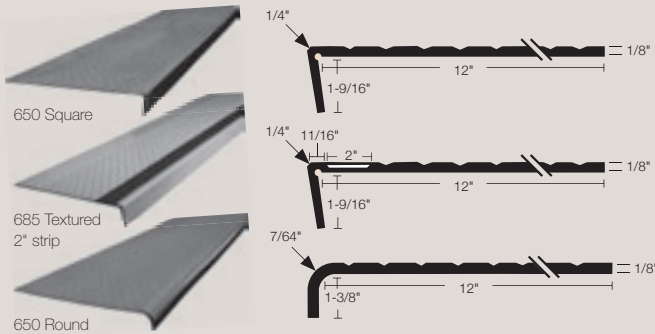

Heavy Duty Hammered One-Piece Tread with Riser
Order Prefix 1900 and 1975

Gauge 13/64" at nose
Depth 20-3/8"
Lengths 36", 42", 48", 54", 60", 72"
Nose Square
Pieces /Ctn 6
Weight /Lin Ft (lb) 2.5
Matching Profile Hammered (SE)

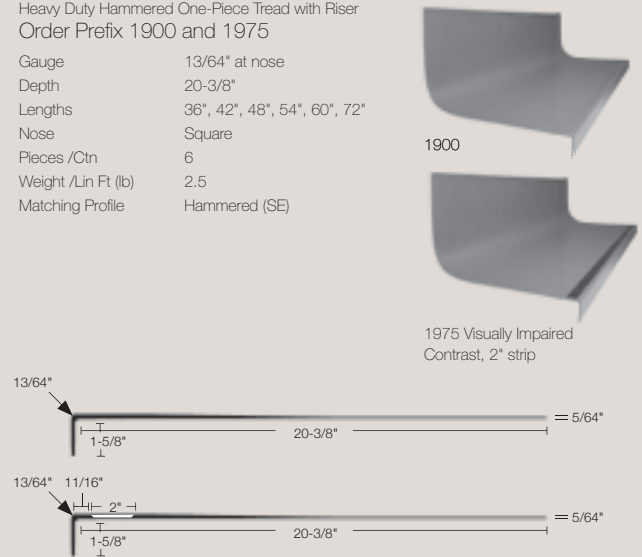

the end user

radial rubber tile and
rubber stair treads

Architect: Salco Construction/Emily Torrence
General Contractor: Salco Construction
Subcontractor: Kennedy Commercial Floors
Project: American Red Cross, Baton Rouge,
Louisiana

stair tread accessories

Rubber risers, stringers, landing tiles, assurance detectable warning tile (ADWT) and other accessories make up the common denominators for use with FLEXCO® rubber stair treads.

- > Coordinating colors match rubber floor tiles, including Radial®, Radial® II, Radial® III, Weave and Square² textures, Evolving Styles®, and SpexTones®
- > Diamond pattern landing tiles are available in Evolving Styles®, SpexTones® and FlexTones® colors to match our stair treads.

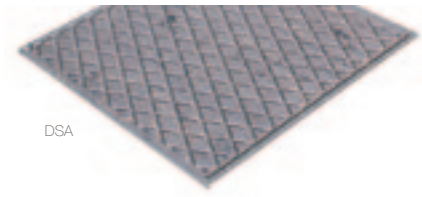

DSA

Diamond Landing Tile
Order Prefix DSA

Gauge	3/16"
Size	27" x 27"
Pieces /Ctn	6
Weight /Ctn (lb)	40.2
Sq Ft /Ctn	30.37

Available in SpexTones®, FlexTones®, and Evolving Styles color palettes.

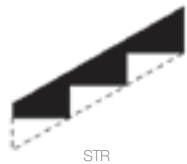

STR

Stringer Material
Order Prefix STR*

Gauge	0.080"
Size	10" x 72"
Pieces /Ctn	10
Weight /Lin Ft (lb)	0.65

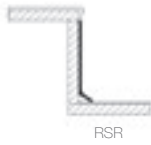

RSR

Risers
Order Prefix RSR**

Gauge	1/8" solid 1/8" marbled
Height	7"
Lengths	36", 42", 48", 54", 60", 72"
Pieces /Ctn	24
Weight /Lin Ft (lb)	0.75

*Risers over 72" will be packaged 10 per carton.
FlexTones up to 108" in risers and all other color selections up to 72".

- * Use prefix SSTR for SpexTones® colors. ** Use prefix SRSR for SpexTones® colors.
- > Rubber stringers and risers available in FlexTones®, SpexTones®, and Evolving Styles® colors.



warning tile

Assurance detectable warning tile features deeply set, pre-grooved strips which can be "felt" through a cane or walking device to alert the visually impaired of approaching stairways. May contribute to LEED® CI and NC credits MR 5 and MR 6.

- > Meets ANSI A117.1/705.3.3 for detectable warnings on walking surfaces.

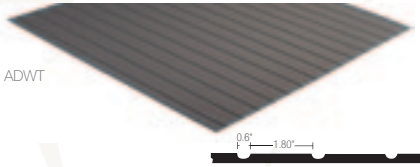

ADWT

Assurance Detectable Warning Tile
Order Prefix ADWT

Gauge	1/8"	1/8"	1/8"
Size	12" x 12"	12" x 36"	36" x 36"
Weight /Ctn (lb)	50	60	60
Sq Ft /Ctn	45	54	54

- > Warning tile colors shown on page 10.

abrasive strips

Rubber and vinyl stair treads with abrasive grit strips are available in Glow-in-the-Dark and other colors to meet OSHA, ADA, CA Title 24 and DIN requirements. The 3/4" strips for the 130 treads are available in black only and the 2" strips are available in all colors listed below.

features and benefits

- > Available to meet ADA requirements for contrasting color.
- > Yellow striping meets OSHA safety standards.
- > Glow-in-the-Dark luminescent safety strips meet DIN 67510.
- > Meets California state standard code Title 24, Section 2-3306 (R).

abrasive grit strip colors

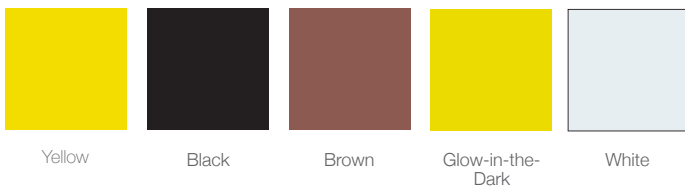

Color selections must be made from actual samples.

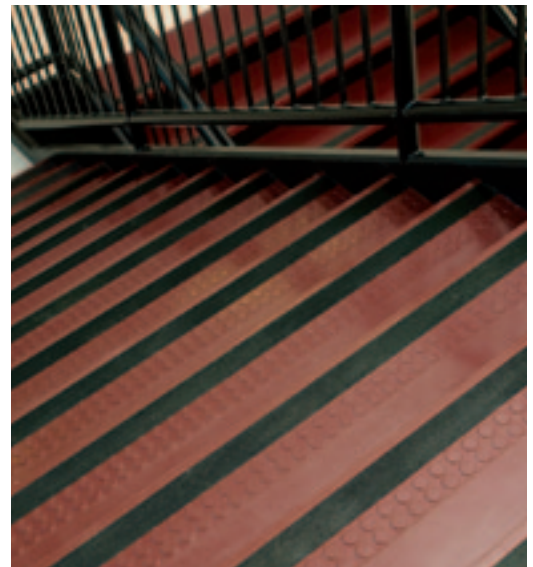

ribbed rubber inserts

FLEXCO® stair treads with ribbed inserts provide a tactile surface that's durable and easy to clean. In addition, the low-profile 2" strips are available in FlexTones® colors and 075 Canary for easy coordination with our wall base, tiles, risers, stringers and accessories.

features and benefits

- > Available in FlexTones® colors plus Canary Yellow.
- > Ideal for vinyl treads as well as all rubber tread in profiles.
- > Available to meet ADA requirements for contrasting color.
- > Canary ribbed inserts meet OSHA safety standards.
- > Meets California state standard code Title 24, Section 2-3306 (R).

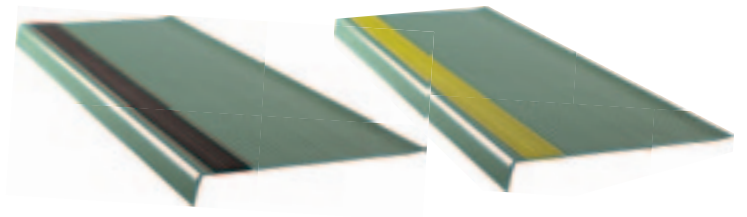

ribbed rubber insert strip colors



stair treads

Made of tough, long-wearing vinyl with a specially designed safety rib surface, FLEXCO® vinyl stair treads are engineered to meet all the demands of high traffic areas – particularly in settings where design counts. May contribute to LEED® CI and NC credits MR 4, MR 5 and MR 6.

features and benefits

- > Commercial weight (VT, 1/4") for heavy traffic conditions.
- > Standard weight (LVT, 5/32") for light commercial and residential applications.
- > Very resilient stair covering.
- > Exceeds ADA recommendations for slip resistance on flat surfaces.
- > Highly resistant to soil and stains.
- > Ribbed inserts or grit strips can be inserted for the visually impaired or extra traction.
- > Meets ASTM F 2169, Type TV.
- > 16/86 Multiperformance Tile & Tread Adhesive contains an antimicrobial agent for added protection against mold and bacteria.
- > Available with an adjustable nose.
- > Treads can be ordered with 2" grit strip or ribbed rubber insert.



* See page 47 for color selection of strips.





specifications

order prefix = LVT
Standard Safety Rib Tread

Gauge 5/32" at nose
Depth 12-13/32" square, 12-11/32" round
Lengths 36", 42", 48", 54", 60", 72", 84", 96", 108"
Nose Round or square
Pieces /Ctn 10 (72" or less), 6 (84" and up)
Weight /Lin Ft (lb) 1.5



order prefix = VT
Commercial Safety Rib Tread

Gauge 1/4" at nose
Depth 12-1/2"
Lengths 36", 42", 48", 54", 60", 72", 84", 96", 108"
Nose Round or square
Pieces /Ctn 6
Weight /Lin Ft (lb) 2



Stair treads must be installed with FLEXCO® 16/86 Multiperformance Tile & Tread Adhesive, FlexTape or 77 Solvent-Free Epoxy Adhesive. FLEXCO® 36 Epoxy Caulking Compound must be applied to nose of the tread. Adjustable nose portion should be secured with contact adhesive or FlexTape according to FLEXCO® instructions.

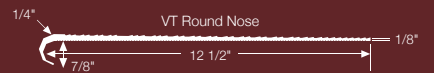
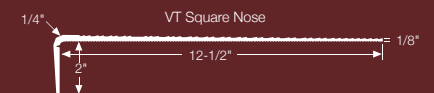
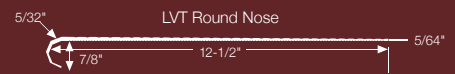
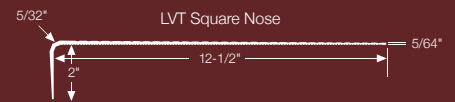

STV

Order Prefix STV
Stringer Material

Gauge 0.080"
Size 10"
Length 50' rolls
Weight/ 38
Lin Ft (lb) 0.75



RSV

Order Prefix RSV
Risers

Gauge 0.080" solid
Height 7"
Length 50' rolls
Weight/ 38
Lin Ft (lb) 0.75

vinyl stair tread colors

Page 10

grit strips / ribbed insert colors

Page 47

flexterior™

Outdoors in rugged conditions, indoors in industrial or commercial applications, FlexTerior™ treads provide a slip resistant surface that's made to last. Made of exterior-grade aluminum and inlaid with an epoxy and abrasive grit blend, FlexTerior™ treads are ideal for installation on new or existing stairs and landings.

features and benefits

- > Resistant to corrosion, extruded aluminum also is heat-treated for strength.
- > Available in two standard lengths, 36" (91.4cm) and 48" (1.22m), or custom lengths to 12 ft. (3.66m). Also available in 9" and 11" depths.
- > Available with 1-3/16" nose measuring from the inside.
- > Colored closed-cell, anti-slip epoxy coating is combined with mineral abrasive grits to resist marring, scratching and chipping.
- > Coal and Sunshine combination meets ADA contrasting color requirements for the visually impaired.
- > Exceeds ADA recommendations for slip resistance on flat surfaces.
- > Two-section tread surface has a 2" strip in front and a wider channel in back, so treads can be one color or two. First color specified represents front channel.
- > Select from many popular colors – all UV stable for fade resistance – or opt for custom color-matching.
- > Factory pre-drilled with countersunk holes for a flush finish and easy installation.

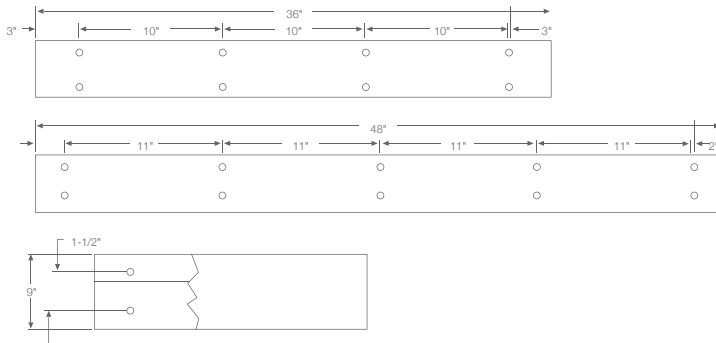

specifications

order prefix:

ODT = FlexTerior™ Treads

Flexterior™ Treads	Stock	Special Order
Gauge	1/4" overall	1/4" overall
Depth	9"	9" and 11"
Lengths	36", 48"	over 48"
Scow Packaging	36" – 9 per set 48" – 13 per set	
Nose	Square	Square
Pieces/Ctn	6	Determined by manufacturer
Weight/Lin Ft (lb)	2.2	2.76

Must specify type of installation for correct screws.

Note: Must indicate concrete or wood installation for proper mechanical fasteners. A premium-grade, exterior polyurethane adhesive approved by the adhesive manufacturer for bonding aluminum directly to concrete, exterior-grade plywood or metal is required.

