

JB Plugger Junction Box Installation Instructions

This junction box provides a convenient location to connect all wiring required for a typical pumping station installation. The junction box employs a receptacle to accept a 120 VAC or 230 VAC piggy-back plug and a pump plug.

The JB Plugger also features an easy-to-use terminal strip which can be used for connecting an alarm system in the junction box.

The JB Plugger package ensures a liquid-tight seal and strain relief for the cable entering the junction box from the pumping station.

JB PLUGGER JUNCTION BOX



- NEMA 4X enclosure rated for outdoor use.
- Hinged cover for convenience.
- Receptacle for pump & pump switch (120V or 230V).
- Custom engineered liquid-tight cord seal.
- Strain relief for pump and float cords provided by cord seal.
- Terminal strip for use with alarm system.
- Separate alarm and pump control circuitry provided by terminal strip.
- Dual safety certification for the United States and Canada.
- Three-year limited warranty.

PREVENTATIVE MAINTENANCE

- Periodically inspect the product. Check that the cable has not become worn or that the housing has not been damaged so as to impair the protection of the product. Replace the product immediately if any damage is found or suspected.
- Periodically check to see that the floats are free to move and operate the pump and alarm.
- Use only SJE-Rhombus[®] replacement parts.

SJE-RHOMBUS[®] THREE-YEAR LIMITED WARRANTY

SJE-RHOMBUS[®] warrants to the original consumer that this product shall be free of manufacturing defects for three years after the date of consumer purchase. During that time period and subject to the conditions set forth below, SJE-RHOMBUS[®] will repair or replace, for the original consumer, any component which proves to be defective due to defective materials or workmanship of SJE-RHOMBUS[®].

THIS EXPRESS WARRANTY DOES NOT APPLY TO THE MOTOR START KIT COMPONENT. SJE-RHOMBUS[®] MAKES NO WARRANTIES OF ANY TYPE WITH RESPECT TO THE MOTOR START KIT.

ELECTRICAL WIRING AND SERVICING OF THIS PRODUCT MUST BE PERFORMED BY A LICENSED ELECTRICIAN.

THIS WARRANTY DOES NOT APPLY: (A) to damage due to lightning or conditions beyond the control of SJE-RHOMBUS[®]; (B) to defects or malfunctions resulting from failure to properly install, operate or maintain the unit in accordance with printed instructions provided; (C) to failures resulting from abuse, misuse, accident, or negligence; (D) to units which are not installed in accordance with applicable local codes, ordinances, or accepted trade practices, and (E) to units repaired and/or modified without prior authorization from SJE-RHOMBUS[®].

Some states do not allow limitations on how long an implied warranty lasts, so the above limitation may not apply to you. Some states do not allow the exclusion or limitation of incidental or consequential damages, so the above limitation or exclusion may not apply to you. This warranty gives you specific legal rights, and you may also have other rights which vary from state to state.

TO OBTAIN WARRANTY SERVICE: The consumer shall assume all responsibility and expense for removal, reinstallation, and freight. Any item to be repaired or replaced under this warranty must be returned to SJE-RHOMBUS[®], or such place as designated by SJE-RHOMBUS[®].

ANY IMPLIED WARRANTIES OF MERCHANTABILITY OR FITNESS ARE LIMITED TO THE DURATION OF THIS WRITTEN WARRANTY. SJE-RHOMBUS[®] SHALL NOT, IN ANY MANNER, BE LIABLE FOR ANY INCIDENTAL OR CONSEQUENTIAL DAMAGES AS A RESULT OF A BREACH OF THIS WRITTEN WARRANTY OR ANY IMPLIED WARRANTY.

WARNING**ELECTRICAL SHOCK HAZARD**

Disconnect power before installing or servicing this product. A qualified service person must install and service this product according to applicable electrical and plumbing codes.

WARNING**EXPLOSION OR FIRE HAZARD**

Do not use this product with flammable liquids. Do not install in hazardous locations as defined by National Electrical Code, ANSI/NFPA 70.

Failure to follow these precautions could result in serious injury or death. Replace product immediately if switch cable becomes damaged or severed. Keep these instructions with warranty after installation. This product must be installed in accordance with National Electric Code, ANSI/NFPA 70 so as to prevent moisture from entering or accumulating within boxes, conduit bodies, fittings, float housing, or cable.

For detailed specifications on this product, or for the complete line of SJE-Rhombus® panel, alarm, and switch products, visit our web-site at www.sjerhombus.com.

INSTALLING THE JB PLUGGER JUNCTION BOX

- Determine where the junction box will be mounted on the riser. Mount the junction box so the base of the enclosure will be at grade once back-filled as shown in Figure A.
NOTE: Bottom mounting to the 3/4" terminal adapter may be preferred in some instances as shown in Figure B.
- Access the riser by providing a 2 3/8" access hole through the riser.
- Place the 6" threaded conduit into the terminal adapter that is already installed in the junction box. Slip one PVC washer over the conduit and slide the conduit through the riser wall as shown in Figure C.
- After installation through the riser, slip the 1/2" gasket and the second PVC washer over the conduit. Determine if the threads provided will be adequate to tighten the assembly to the riser. If threading is not adequate, remove the assembly and shorten the conduit until threading is adequate as shown in Figure C. **NOTE: The 1/2" gasket should compress approximately 1/4" when lock nut is tightened.**
- Repeat steps 3 and 4 until desired length is achieved. With PVC solvent, weld the conduit into the terminal adapter.
- Mount the 3/4" terminal adapter to the bottom of the junction box with the O-ring and lock nut provided. A 1 1/16" hole should be provided for the adapter.
- Mount the assembly through the riser as described in steps 3 and 4. Using the 2" lock nut, compress the gasket and riser to secure the junction box.
- Remove the backplate assembly from the enclosure. Bring the wiring for the pump power and alarm junction through the 3/4" terminal adapter. Connect the conductors for the pump to the terminal block; connect N (neutral) to position 1, and L1 (line) to position 2. Connect L2 to position 1 for 230 VAC installations. **NOTE: Overload protection, branch circuit protection and main disconnect provided by others.** Connect the conductors for the alarm circuit to positions 3 and 4 as shown in Figures C and D. Place the backplate assembly back into the enclosure. **NOTE: If an alarm system is not used, plug the third open position in the cord seal with the PVC plug provided.**
- Pass the piggy-back plug, pump plug and alarm float cables through the 2" conduit.
- With the three position cord seal, route the three cables through the seal, leaving approximately 8" of cable to work with. Insert the cord seal into the panel terminal adapter and tighten the hex nut until adequate strain relief is achieved.
- Gather all ground wires, including grounding conductor on the cord seal, and washer. Route and secure to ground terminal as shown in Figures C and D.
- Connect the conductors from the alarm float switch to positions 3 and 4. Coil remaining cable into the junction box as shown in Figures C and D.
- Seal the 3/4" terminal adapter with a conduit sealing compound.
- Plug the piggy-back plug and pump plug into the receptacle as shown in Figure D.
- Secure the junction box cover using the two preinstalled screws.
- Turn on power.
- Check the installation by manually tipping the floats on the pump and then the alarm float.
- Test the unit periodically to insure proper operation.

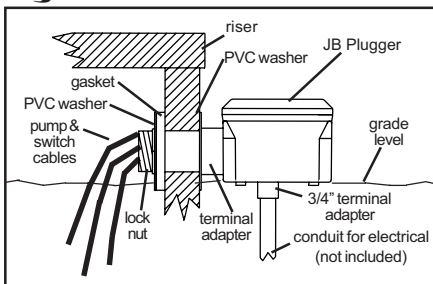
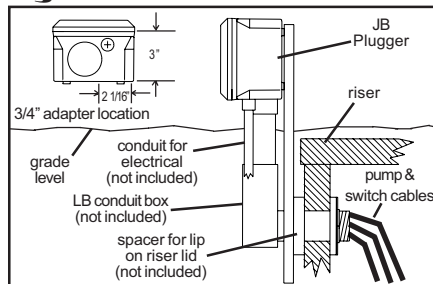
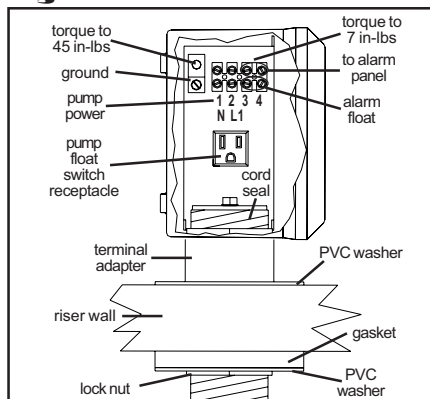
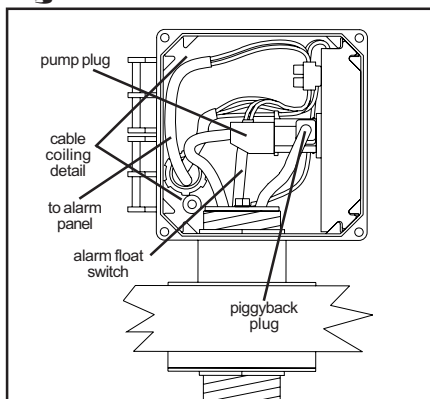
Figure A**Figure B****Figure C****Figure D**

SJE-Rhombus
CONTROLS

22650 County Highway 6 ■ P.O. Box 1708 ■ Detroit Lakes, Minnesota 56502 USA
1-888-DIAL-SJE (1-888-342-5753) ■ Phone: 218-847-1317 ■ Fax: 218-847-4617 ■ E-mail: sje@sjerhombus.com