



F1240

UTILITY AREA DRAIN

Internet address: www.mifab.com

Toll Free: 1-800-465-2736

Canada Toll Free: 1-800-387-3880

SPECIFICATION: MIFAB Series F124 ___ (specify connection size) lacquered ductile iron area drain with 1/2" (13) thick, 6-1/2" (165) diameter heavy duty ductile iron grate with stainless steel screws. Recommended for use in vehicular traffic areas.

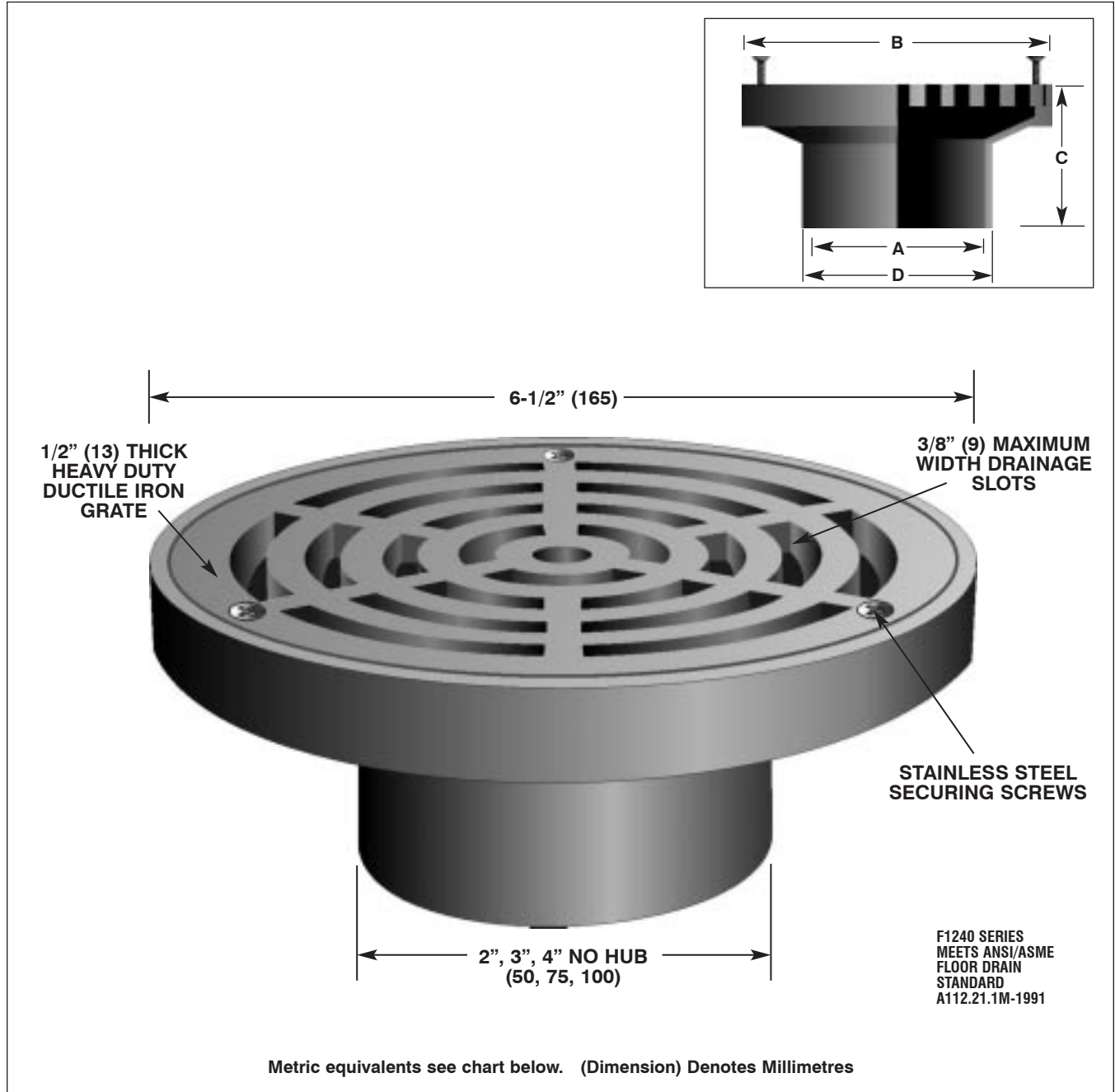

MODEL NO.	PRODUCT DESCRIPTION	A	B	C	D	ANSI/ASME LOAD RATING	GRATE THICKNESS	FREE AREA
		IN	IN	IN	IN			
F1242	2" (50) No hub C.I. body	2" (50)	6-1/2" (165)	3" (75)	2-3/8" (60)	Heavy Duty	1/2" (13)	10 in ² (6,452 ²)
F1243	3" (75) No hub C.I. body	3" (75)	6-1/2" (165)	3" (75)	3-3/8" (86)	Heavy Duty	1/2" (13)	
F1244	4" (100) No hub C.I. body	4" (100)	6-1/2" (165)	3" (75)	4-3/8" (111)	Heavy Duty	1/2" (13)	

OPTIONAL VARIATIONS:

Vandal proof

suffix -6