



# F1510

## AREA DRAIN WITH HEAVY DUTY GRATE AND SEDIMENT BUCKET (CONFORMS TO CSA STD.S413m)

**Specification:** MIFAB® Series F1510 lacquered cast iron floor drain with deep sump body, wide anchor flange, weepholes and adjustable collar with square heavy duty ductile iron hinged tractor grate with four piece surface membrane clamp, sediment bucket and free area of 51 in<sup>2</sup> (32,903<sup>2</sup>).

**Function:** For installation in parking structures where a heavy duty area drain with surface membrane clamps and the security of a hinged grate are required.

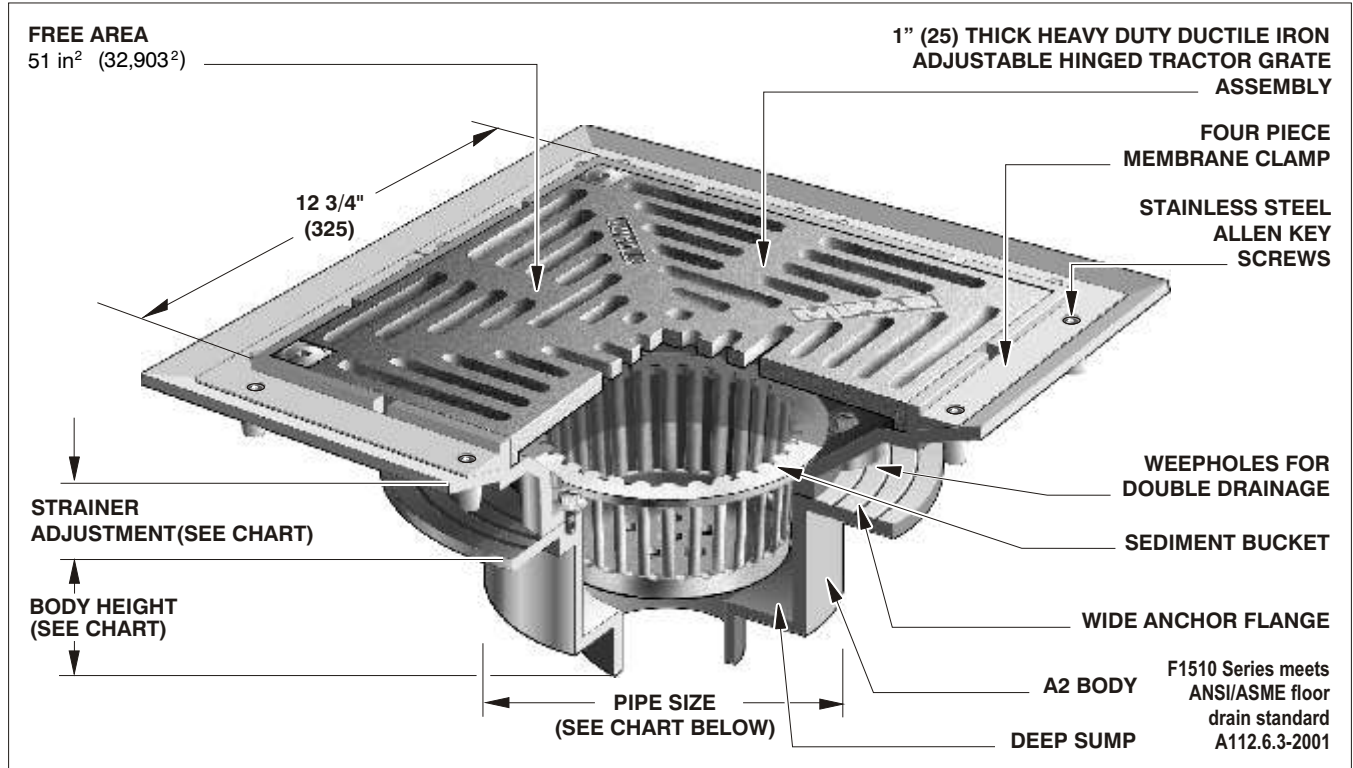

Metric equivalent see chart below. (Dimensions) Donates Millimeters

STRAINER DIAMETER	STRAINER ADJUSTMENT		ANSI/ASME RATING		BODY HEIGHT				
	MIN	MAX	FREE AREA	LOAD RATING	PIPE SIZE	NO HUB (STANDARD)	PUSH ON (P)	THREADED (T)	INSIDE CAULK (X)
12" x 12" (300 x 300)	2 1/4" (57)	4 1/8 (105)	51 in. <sup>2</sup> (32,903 <sup>2</sup> )	ANSI/ASME	2" (51)	5 7/16" (138)	6 1/8" (156)	6 1/4" (159)	7 1/8" (181)
				LOAD CLASS	3" (76)	5 7/16" (138)	6 1/8" (156)	6 1/4" (159)	7 1/8" (206)
				"SPECIAL DUTY"	4" (102)	5 7/16" (138)	6 1/8" (156)	6 1/4" (159)	7 1/8" (206)
				(OVER 10,000	5" (127)	5 7/16" (138)	6 1/8" (156)	6 1/4" (159)	
				LBS.)	6" (152)	5 7/8" (149)	8" (203)	6 1/4" (159)	
				8" (203)	5 7/8" (149)		use A7-8X		

**OPTIONAL VARIATIONS:**

- 3M epoxy finish -3M
- Stainless steel strainer (vener) -3
- Ductile iron grate (standard) -4
- Security screws (T-20 torx & pin) -6
- Trap seal primer tapping -7
- Backwater valve (3", 4") -8
- Acid resistant epoxy coating -11
- Galvanized grate and frame -12
- All galvanized -13
- 2" Extension (-TE) -15
- Bronze body -27
- Stainless steel body (type 304) -28

**SUFFIX**

- Stainless steel body (type 316) -29
- PVC socket connection body -30
- ABS socket connection body -31
- Underdeck clamp -40
- Sump receiver -41
- All aluminum -80
- Threaded side outlet -90
- Membrane clamp -C
- Push on outlet -P
- Threaded outlet -T
- Inside caulk outlet -X
- No hub outlet (standard)

Job Name \_\_\_\_\_ Job Location \_\_\_\_\_  
 Engineer \_\_\_\_\_ Contractor \_\_\_\_\_  
 Model No: \_\_\_\_\_ Purchase Order No: \_\_\_\_\_

MIFAB reserves the right to make changes in material and design without formal notice and obligation.