

CONTROLVIEW™ XTREME

PAN/TILT/ZOOM CAMERA CONTROL SYSTEMS

The Vaddio ControlVIEW Xtreme Camera Control System begins a new generation in camera control systems. The system is designed to control up to four PTZ cameras and assign up to 72 total system



camera preset positions to any or all cameras. The ControlVIEW Xtreme works with any VISCA controllable PTZ camera and has four video inputs for cameras one through four. The internal four port video switcher automatically switches the video to that of the triggered camera. Vaddio has a complete line of camera control triggering devices including the AutoVIEW™ IR, StepVIEW™, TouchVIEW™ and MicVIEW™ that can automate your camera control projects. Presets can also be controlled by any number of different types of devices such as microphone mixers, control systems, and contact closure devices.

INCLUDED ACCESSORIES

- 12 VDC power supply
- IR remote control
- Rack ears
- Terminal connectors
- Owners manual

TECHNICAL FEATURES

72 Camera Presets

The ControlVIEW Xtreme can store up to 72 camera presets in the main control system. This allows you to have as many presets as you want and not be limited by the internal preset limitations of the camera. Any combination of presets can be assigned as needed between the four cameras.

Four Port Video Switcher

A four port S-Video switcher is built into the ControlVIEW Xtreme. The switcher can be automatically switched by preset activation, manually switched on the front panel or be switched by using the IR remote control. The system programming allows for setting up a default camera video selection or a camera preset default.

VISCA Camera Compatibility

The ControlVIEW Xtreme can support any PTZ camera that has a complete VISCA camera control command set (such as the Sony® EVI Series Cameras). Up to four PTZ cameras can be controlled by the ControlVIEW Xtreme.

Universal Microphone Mixer Camera Control Interface

Provides an integrator with an easy solution to provide PTZ camera control with a new or existing microphone mixer that has outputs for gate status (also called logic outputs). Logic outputs normally refer to a software/hardware mixer that has variable gate status control outputs that tell a external control device what microphone is being switched on and off. The ControlVIEW Xtreme takes that signal and switches to the appropriate camera and preset assigned to that microphone. Signal switching on most mixers can be done by voice activation or by push-to-talk microphones. The ControlVIEW Xtreme can then be programmed to assign that microphone to any one of four cameras and then give it one of the 72 system camera presets. ControlVIEW Xtreme only requires that the mixers logic/gate status output must provide an 'active high' (up to 5 V) or 'active low' (0 V) signaling.

Automatic Camera Detection

ControlVIEW Xtreme automatically detects the number and type of camera on the system and assigns them accordingly. Camera assignment is based on their location on the daisy-chain control string.

IR Remote Control

An IR remote control is included with the ControlVIEW Xtreme. The remote provides the ability to control camera selection, PTZ functions and all camera preset programming.

TECHNICAL SPECIFICATIONS

Serial Communication	Data Rate: 9600, 8N1 Pass-through, Control and Data
Video Input	– (4) S-Video inputs
Video Output	S-Video and Composite
Switcher Input Controller	<ul style="list-style-type: none"> – (2) 12-pin Phoenix type connectors for control triggers – (2) DB25 connector inputs (24 inputs + 1 ground each) for control triggering – (1) 2-pin Phoenix type connector for ground – (1) 2-pin Phoenix type connector for +5 V – (2) RS-232 Serial Ports (one to camera and one to AMX®/Crestron®) – (1) RS-232 Instruction Set for Camera Control – (1) RS-232 Pass-through Function for external control systems – (1) 4-Port Video Switcher Controller
Weight	4.60lbs/2.08kg
Dimensions	
Depth	6 1/4”/15.9cm
Width	16 3/4”/42.6cm
Height	3 1/2”/8.81cm
Power Supply	12 VDC, 750mA

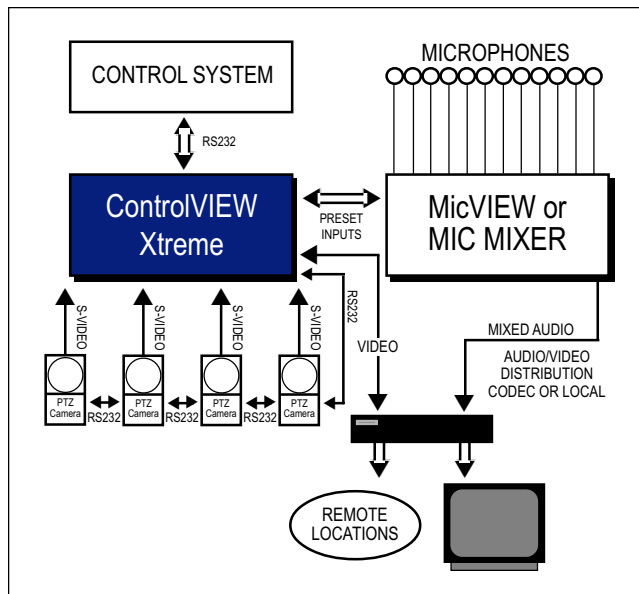

Figure 1 – ControlVIEW Xtreme setup, audio mixer.

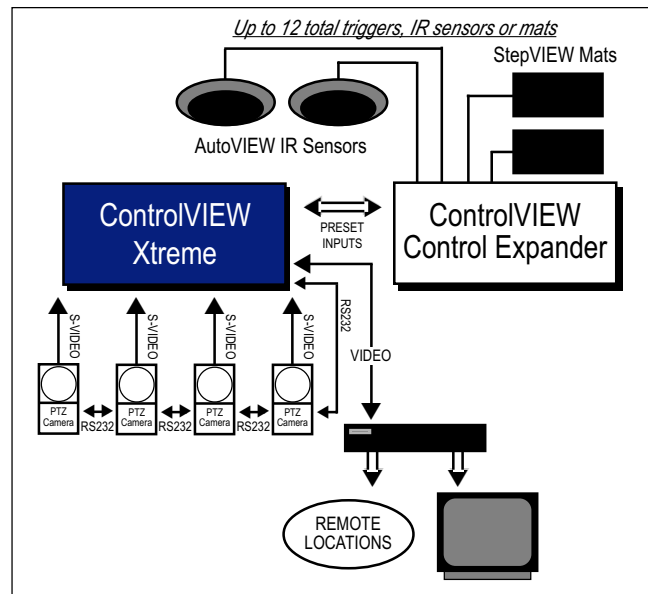

Figure 2 – ControlVIEW Xtreme setup, AutoVIEW.

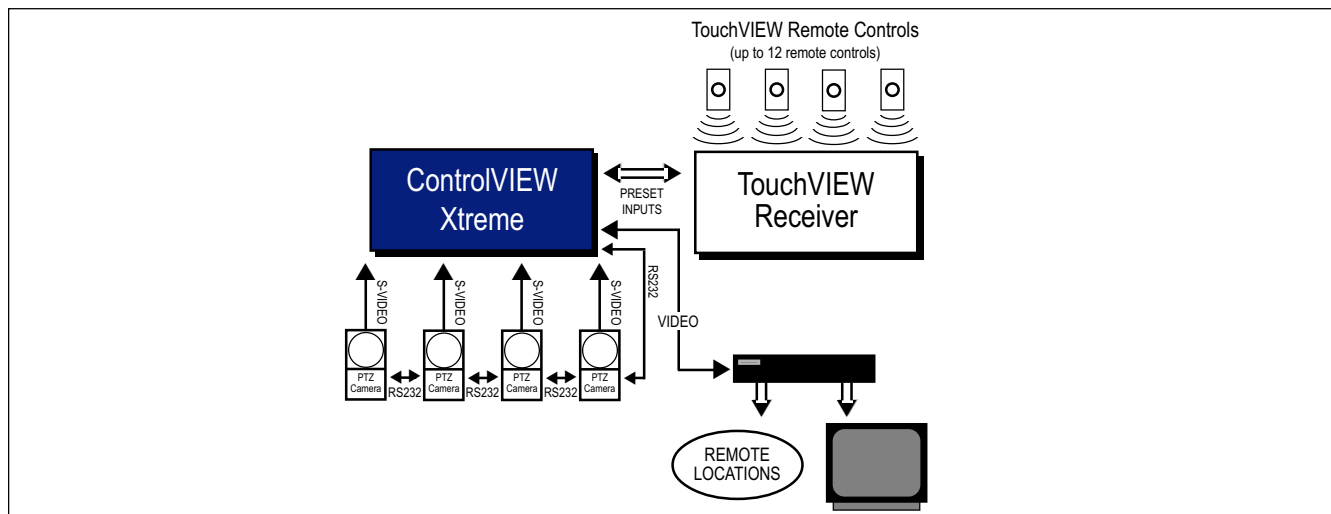

Figure 3 – ControlVIEW Xtreme setup, TouchVIEW.

CONTROL OPTIONS

The following equipment can be integrated and provide camera preset control triggering to the ControlVIEW Xtreme Camera Controller.

Audio/Mixers

With a ControlVIEW Xtreme you can interface with any mixer that provides an 'active high' (up to 5 V) or 'active low' (0 V) state output.

MicVIEW™

Vaddio's MicVIEW is an automated 12-input microphone switching/mixing system that was designed for distance education and other videoconferencing applications. MicVIEW integrates directly with the ControlVIEW Xtreme Camera Control by using the optional link cable. Up to eight MicVIEW units can be linked together to get a total of 96 microphones.

TouchVIEW™

Vaddio's TouchVIEW Wireless Remote Control System provides for individual RF remote control buttons that can be placed on whiteboards, podiums, desktops, etc. so that the presenter can switch to any video preset they desire as they move around the room. Up to 62 remote buttons can be used on a system.

AutoVIEW™

Vaddio's AutoVIEW IR Ceiling-Mounted Presenter Camera Control System provides for automated presenter control of camera presets programmed in the ControlVIEW Xtreme. At the IR sensor detects the presenter, cameras and presets change automatically allowing for hands-free camera tracking. The AutoVIEW Active IR Sensor is adjustable for precise presenter control over each IR sensing zone.

StepVIEW™

The StepVIEW System works by having the presenter step on the heavy-duty, presence sensing and non-slip auto locator mats in the area that the cameras are to be used. Camera presets are assigned to those mat locations and programmed into the ControlVIEW Xtreme. As the presenter walks to different areas in the room the mats trigger the cameras to move to that area automatically.

Control Systems

The Vaddio ControlVIEW Xtreme can also be integrated with a control system such as Crestron® or AMX® by using the RS-232 control port.

Contact Closure Interface

The preset input interface allows for connection of external devices such as switches, sensors, floormats, etc. The contact must see an "active high" (up to 5 V) or "active low" (0 V).

PROGRAM FEATURES

Front Panel Programming

A scrolling LCD menu display provides users with the ability to do system programming and can also be used for user system control of PTZ cameras and system functions.

IR Remote Programming

System programming can be done with the provided IR remote control.

Switching Delay Settings

Both the camera switching delay and the video switching delay can be programmed to select the appropriate delay time before switching to the default position or another camera. The settings are from 0 to 60 seconds. There is also an OFF position which turns off the default position function.

Preset Recall ON/OFF

When the preset recall is ON the system switches to the default camera and user selected preset. When the preset recall is OFF, only the default camera video is selected.

Default Camera Selector

Selects what camera will be the default camera when no other camera is being activated by the system.

Camera Video Delay

This feature delays switching the camera's video output until the camera moves and zooms into place. This feature is activated when switching between different cameras.

Crestron or AMX

The ControlVIEW Xtreme allows RS-232 control through the external port.

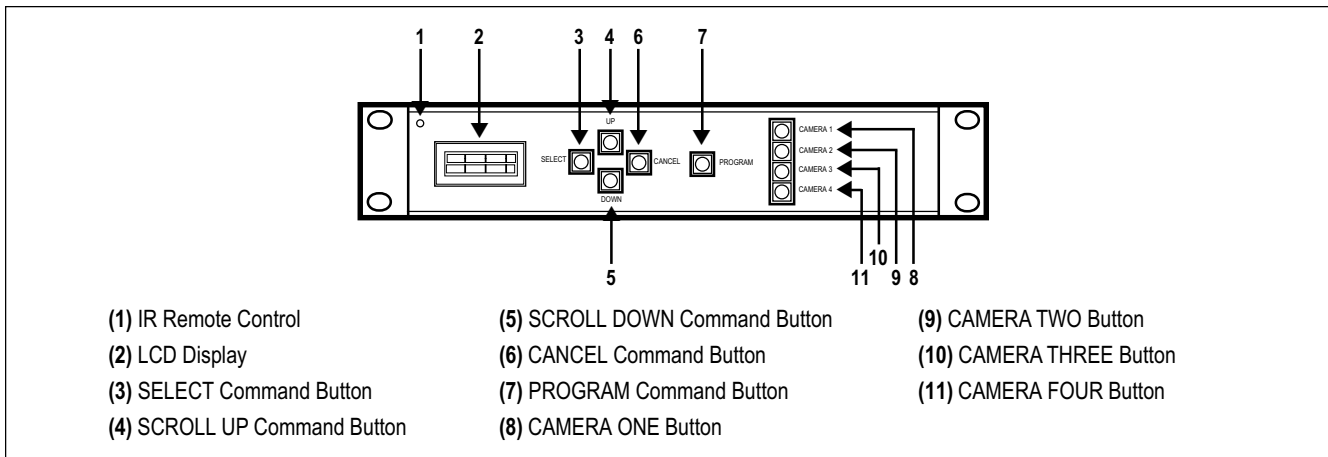

Figure 4 – ControlVIEW Xtreme front panel functions.9

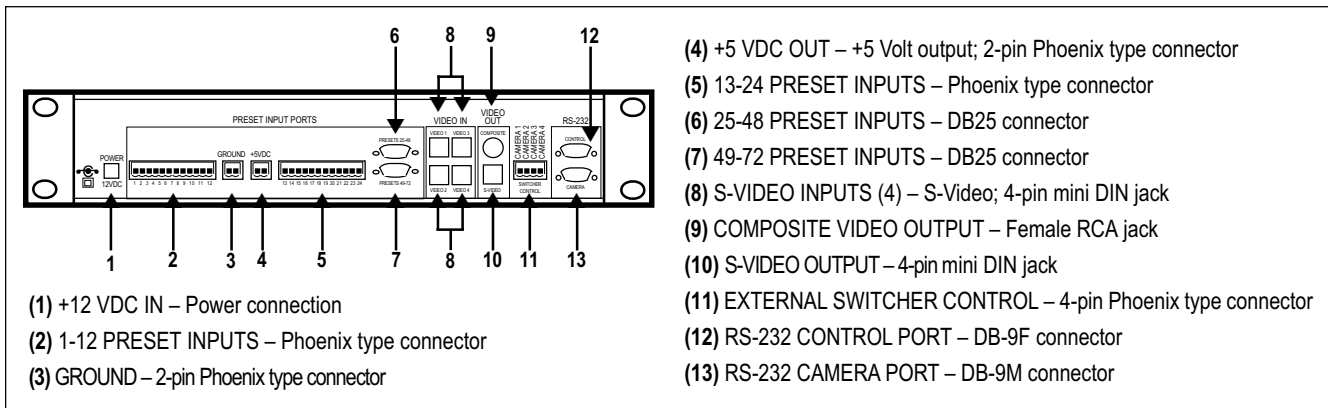

Figure 5 – ControlVIEW Xtreme back panel functions.

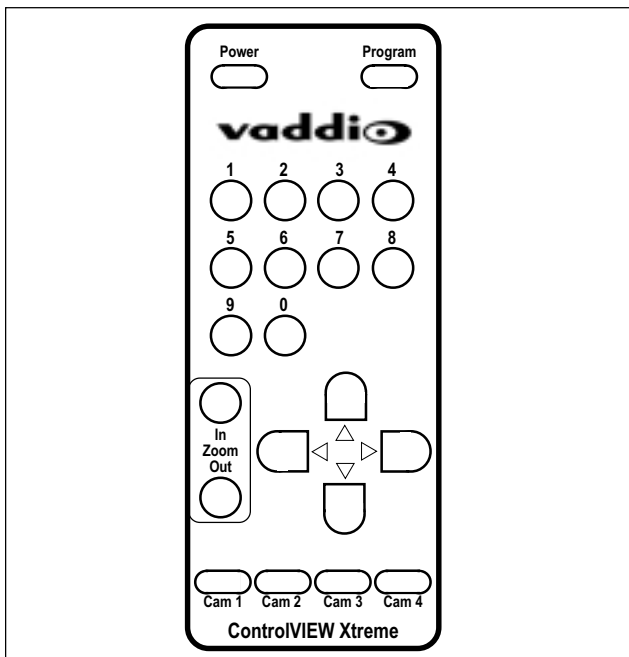

Figure 6 – ControlVIEW Xtreme IR remote control.



9433 Science Center Drive • New Hope, MN 55428
 Toll Free: 800.572.2011 • Phone: 763.971-4400 • Fax: 763.971.4464
 www.vaddio.com