

F1580 SERIES 24" x 24" HEAVY DUTY DEEP SUMP AREA DRAIN WITH BOTTOM OUTLET

F1580
SERIES

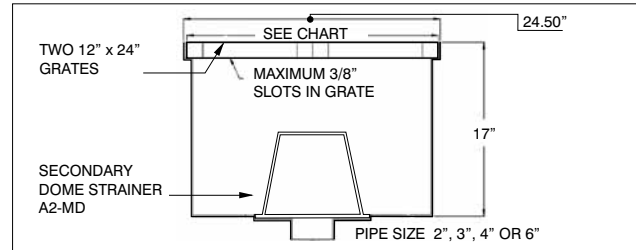
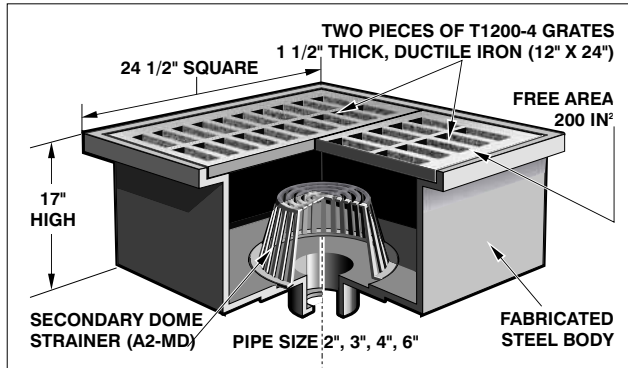

24" SQ HEAVY DUTY DEEP SUMP AREA DRAIN W/BOTTOM OUTLET			
MODEL NUMBER	WT. Lbs	BAKED EPOXY COATED STEEL BODY WITH:	
		DUCTILE IRON (-4)	STAINLESS STEEL (VENEER) (-3)
F1582,3,4,6	400.00	\$6967.00	\$8363.00

F1580 OPTIONAL VARIATIONS:

SUFFIX	DESCRIPTION	LIST PRICE	SUFFIX	DESCRIPTION	LIST PRICE
-5	Sediment bucket (FS1700-PB)	\$230.00	-13	All galvanized (Min. order 25 pcs. or P.O.A.)	\$ 977.00
-6	Vandal proof secured grate (TR30 Torx and pin)	\$234.00	-28	Stainless Steel Body (Type 304)	P.O.A.
-8	Backwater valve (BV1250 Series) (2", 3", 4")	\$195.00	-FL	Anchor flange	\$ 381.00
-12	Galvanized grate (Min. order 25 pcs. or P.O.A.)	\$489.00	-FLC	Anchor flange and membrane clamp	\$ 945.00

F1590 SERIES 24" x 24" HEAVY DUTY AREA DRAIN WITH OFFSET BOTTOM OUTLET

F1590
SERIES

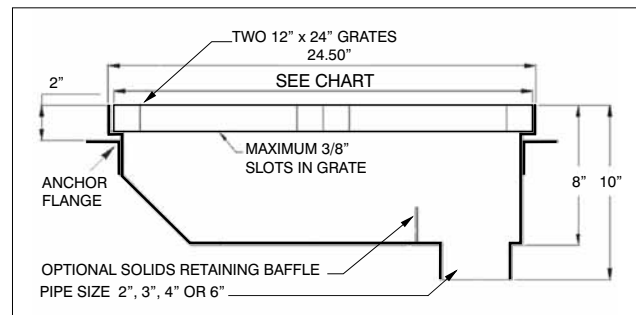
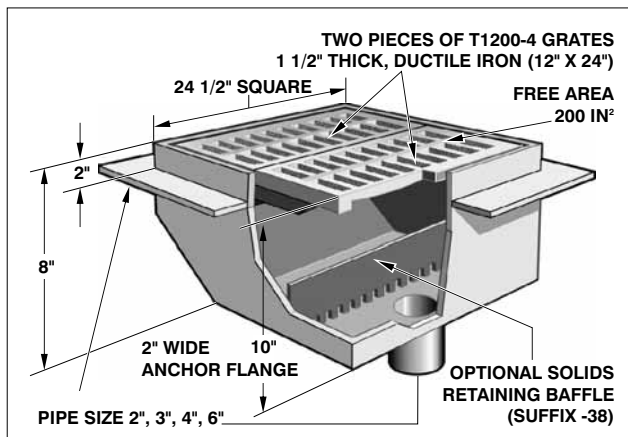

24" SQ. HEAVY DUTY AREA DRAIN WITH OFFSET BOTTOM OUTLET			
MODEL NUMBER	WT. Lbs	BAKED EPOXY COATED STEEL BODY WITH:	
		DUCTILE IRON (-4)	STAINLESS STEEL (VENEER) (-3)
F1592,3,4,6	400.00	\$6967.00	\$8363.00

F1590 OPTIONAL VARIATIONS:

SUFFIX	DESCRIPTION	LIST PRICE	SUFFIX	DESCRIPTION	LIST PRICE
-6	Vandal proof secured grate (TR30 Torx and pin)	\$234.00	-13	All galvanized (Min. order 25 pcs. or P.O.A.)	\$977.00
-8	Backwater valve (BV1250 Series) (2", 3", 4")	\$195.00	-28	Stainless Steel Body (Type 304)	P.O.A.
-12	Galvanized grate (Min. order 25 pcs. or P.O.A.)	\$489.00	-38	Solids retaining baffle	\$340.00
			-C	Membrane clamp	\$564.00

F1590-90 SERIES 24" x 24" HEAVY DUTY PARKING AREA DRAIN WITH SIDE OUTLET

F1590-90
SERIES

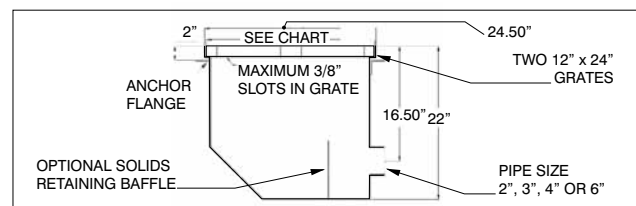
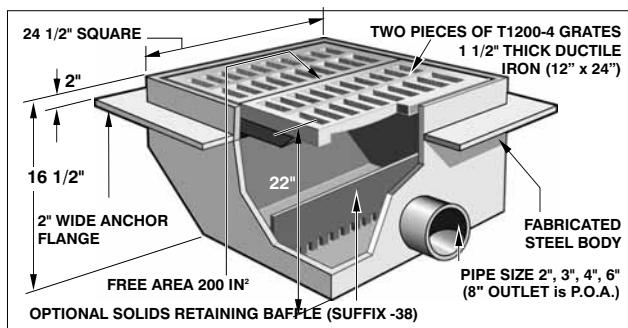

24" X 24" HEAVY DUTY PARKING AREA DRAIN WITH SIDE OUTLET			
MODEL NUMBER	WT. Lbs	BAKED EPOXY COATED STEEL BODY WITH:	
		DUCTILE IRON (-4)	STAINLESS STEEL (VENEER) (-3)
F1592,3,4,6-90	400.00	\$6967.00	\$8363.00

F1590-90 OPTIONAL VARIATIONS:

SUFFIX	DESCRIPTION	LIST PRICE	SUFFIX	DESCRIPTION	LIST PRICE
-6	Vandal proof secured grate (TR30 Torx and pin)	\$234.00	-28	Stainless Steel Body (Type 304)	P.O.A.
-12	Galvanized grate (Min. order 25 pcs. or P.O.A.)	\$489.00	-38	Solids retaining baffle	\$340.00
-13	All galvanized (Min. order 25 pcs. or P.O.A.)	\$977.00	-C	Membrane clamp	\$564.00

Design and dimensions are subject to modification. Prices do not include applicable taxes. Visit www.mifab.com for the most recent product information.

MIFAB, Inc., 1321 West 119th Street, Chicago, Illinois 60643-5109, USA

Toll Free 1-800-465-2736, Fax 773-341-3049

All sales subject to MIFAB's Terms and Warranties. Please refer to inside front cover.