

## F1100-C-ZS FLOOR DRAIN WITH SQUARE STRAINER AND ELASTOMERIC FLANGE F1100-C-ZS SERIES

SERIES

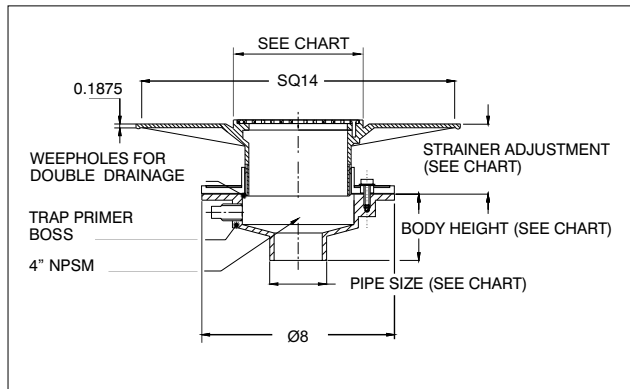
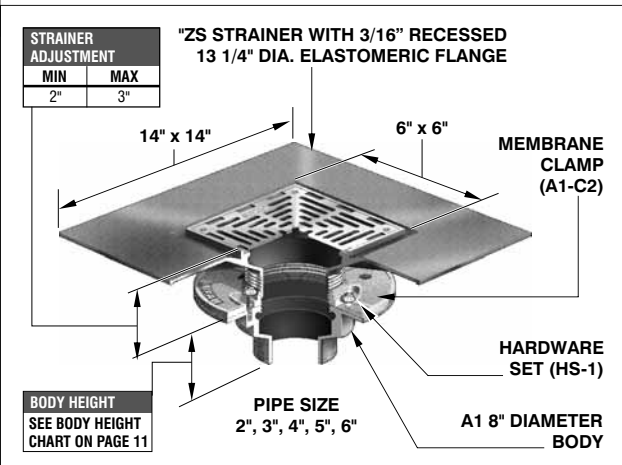

ANSI/ASME RATING		
STRAINER	FREE AREA	LOAD RATING
ZS-1	12 IN <sup>2</sup>	UP TO 2000 lbs
ZS-3	12 IN <sup>2</sup>	5000 - 7499 lbs

PARTS			
A1 BODY	ZS-(*)	A1-C2	HS-1

(\*) Denotes strainer finish (-1 or -3)

FLOOR DRAIN WITH SQUARE STRAINER AND ELASTOMERIC FLANGE			
MODEL NUMBER	WT. Lbs	STRAINER SIZE	LIST PRICE: NICKEL BRONZE (-1) STAINLESS STEEL (-3)
F1102,3,4-C-ZS	12.50	6" x 6"	\$718.00

WHEN NO MEMBRANE CLAMP IS REQUIRED, DELETE SUFFIX (-C) AND DEDUCT \$43.00

OPTIONAL VARIATIONS CONTINUE ON PAGE 23 CONTINUE ▶▶▶

## F1100-C-90 FLOOR DRAIN WITH SIDE OUTLET F1100-C-90 SERIES

SERIES

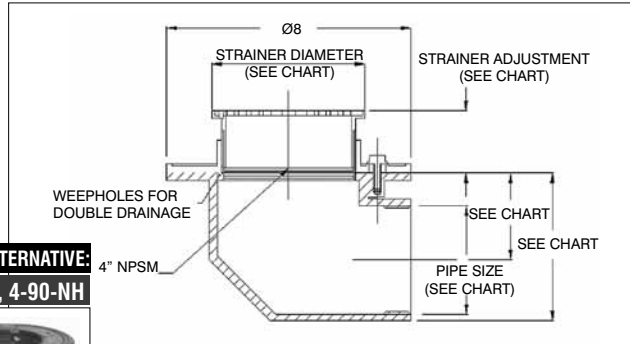
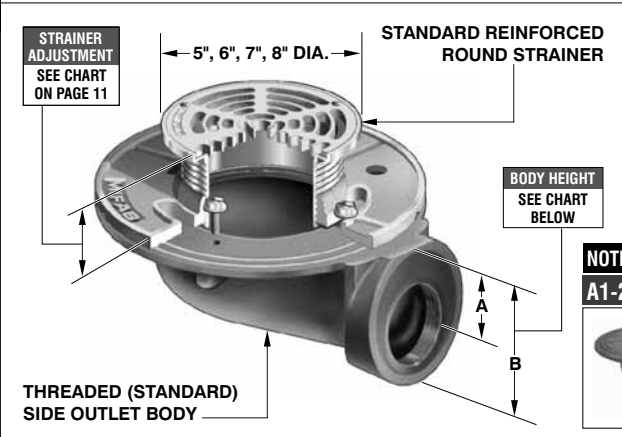

ANSI/ASME RATING	
FREE AREA / LOAD RATING	
SEE STD (*) STRAINER CHART ON PAGE 11	



(Photo of A1 No Hub side outlet body)  
Add Suffix -NH for no hub outlet and specify integral A1 no hub body A1-2,3,4-90-NH. No Add.

PARTS	
A1 (+)T-90	(*)-(**)
A1-C2	HS-1

FOR ALL OTHER STRAINER TYPES, TAKE STRAINER PRICE FROM PAGES 24-25 AND ADD \$168.00 FOR 2" AND 3" THREADED SIDE OUTLET BODY AND \$215 FOR 4" THREADED SIDE OUTLET BODY

FLOOR DRAIN WITH SIDE OUTLET					
MODEL NUMBER	WT. Lbs	OUTLET SIZE	STRAINER SIZE	LIST PRICE: NICKEL BRONZE (-1) STAINLESS STEEL (-3)	LIST PRICE DUCTILE IRON (-4)
F1102,3-C-90-5	7.50	2", 3"	5" DIA	\$361.00	\$330.00
F1104-C-90-5	8.00	4"	5" DIA	\$408.00	\$377.00
F1102,3-C-90-6	8.50	2", 3"	6" DIA	\$413.00	-
F1104-C-90-6	9.00	4"	6" DIA	\$460.00	-
F1102,3-C-90-7	9.00	2", 3"	7" DIA	\$462.00	-
F1104-C-90-7	9.50	4"	7" DIA	\$509.00	-
F1102,3-C-90-8	9.00	2", 3"	8" DIA	\$552.00	\$455.00
F1104-C-90-8	9.50	4"	8" DIA	\$599.00	\$502.00

WHEN NO MEMBRANE CLAMP IS REQUIRED, DELETE SUFFIX (-C) AND DEDUCT \$43.00

All sales subject to MIFAB's Terms and Warranties. Please refer to inside front cover.

Design and dimensions are subject to modification. Prices do not include applicable taxes. Visit [www.mifab.com](http://www.mifab.com) for the most recent product information.

MIFAB, Inc., 1321 West 119th Street, Chicago, Illinois 60643-5109, USA

Toll Free 1-800-465-2736, Fax 773-341-3049

All sales subject to MIFAB's Terms and Warranties. Please refer to inside front cover.