

F1540
SERIES

PARKING AREA DRAIN WITH 12" ROUND HEAVY DUTY TRACTOR GRATE WITH DEEP SUMP AND HEAVY DUTY MEMBRANE COLLAR WITH SEEPAGE OPENINGS

F1540
SERIES

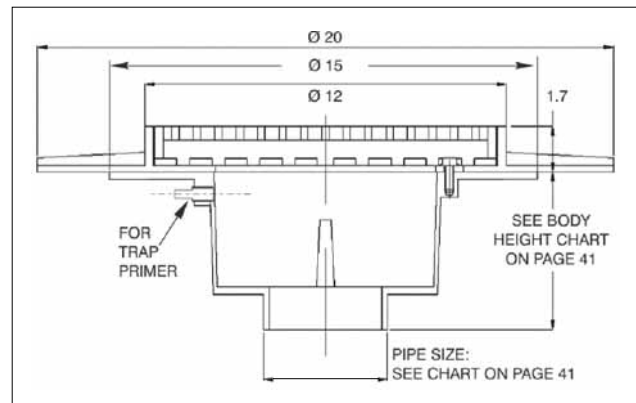
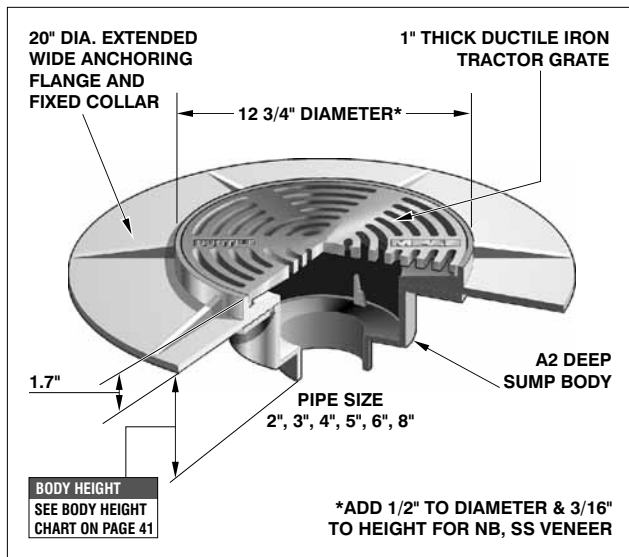

PARTS	A2 BODY	F1540-TA-(*)	HS-1
(*) Denotes Strainer finish (-1, -3 or -4)			

PARKING AREA DRAIN WITH 12" ROUND HEAVY DUTY TRACTOR GRATE					
MODEL NUMBER	WT. Lbs	STRAINER DESCRIPTION	LIST PRICE LACQUERED CAST IRON BODY WITH:		
			DUCTILE IRON (-4)	NICKEL BRONZE (VENEER) (-1)	STAINLESS STEEL (VENEER) (-3)
F1542,3,4,6,8	75.00	12" Dia. tractor grate	\$1303.00	\$1978.00	\$1978.00

F1540 AND F1550 OPTIONAL VARIATIONS:					
SUFFIX	DESCRIPTION	LIST PRICE	SUFFIX	DESCRIPTION	LIST PRICE
-5	Sediment bucket (FS1750-PB)	\$ 111.00	-13	All galvanized (Min order 25 pcs or P.O.A.)	\$564.00
-6	Vandal proof secured grate (TR30 Torx and pin)	\$ 76.00	-90	Threaded side outlet (2", 3" or 4")	\$190.00
-7	Trap seal primer tapping	\$ 77.00	-30	PVC Socket Connection Body* (2", 3", 4")	No Add
-8	Backwater valve (BV1250 Series) (2", 3", 4")	\$ 195.00	-31	ABS Socket Connection Body* (2", 3", 4")	No Add
-11	Acid resistant epoxy coating (Min. Order 25 pcs. or P.O.A.)	\$ 564.00	P	Push on outlet (2", 3", 4" or 6")	No Add
-12	Galvanized grate (Min. order 25 pcs. or P.O.A.)	\$ 283.00	T	Threaded outlet (2", 3", 4" or 6")	\$ 40.00
			X	Inside caulk outlet (2", 3", 4" or 6")	No Add

*PVC/ABS Socket bodies available for 2", 3" or 4" connection sizes

F1550
SERIES

PARKING AREA DRAIN WITH 15" ROUND HEAVY DUTY TRACTOR GRATE WITH DEEP SUMP AND HEAVY DUTY MEMBRANE COLLAR WITH SEEPAGE OPENINGS

F1550
SERIES

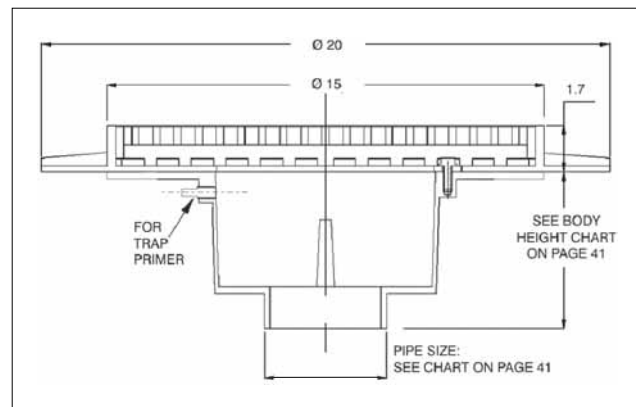
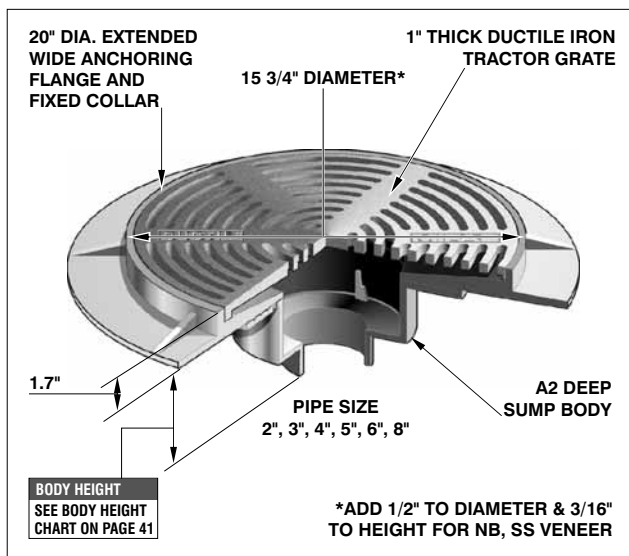

PARTS	A2 BODY	F1550-TA-(*)	HS-1
(*) Denotes Strainer finish (-1, -3 or -4)			

PARKING AREA DRAIN WITH 15" ROUND HEAVY DUTY TRACTOR GRATE WITH DEEP SUMP					
MODEL NUMBER	WT. Lbs	STRAINER DESCRIPTION	LIST PRICE LACQUERED CAST IRON BODY WITH:		
			DUCTILE IRON (-4)	NICKEL BRONZE (VENEER) (-1)	STAINLESS STEEL (VENEER) (-3)
F1552,3,4,6,8	75.00	15" Dia. tractor grate	\$1627.00	\$2092.00	\$2092.00

Design and dimensions are subject to modification. Prices do not include applicable taxes. Visit www.mifab.com for the most recent product information.

MIFAB, Inc., 1321 West 119th Street, Chicago, Illinois 60643-5109, USA

Toll Free 1-800-465-2736, Fax 773-341-3049

All sales subject to MIFAB's Terms and Warranties. Please refer to inside front cover.

PARKING AREA DRAINS