

C1100-XS SERIES FLOOR CLEANOUT WITH HEAVY DUTY SQUARE TOP

C1100-XS SERIES

CLEANOUTS

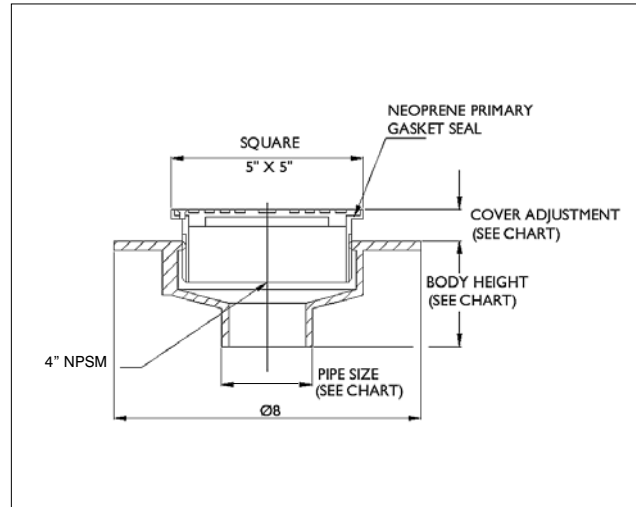
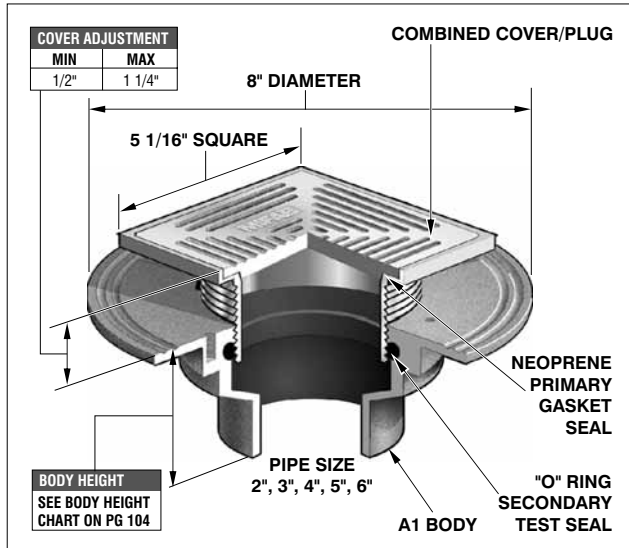

SEE PAGE 106 FOR C1100-XS OPTIONAL VARIATIONS

C1100-XS FLOOR CLEANOUT WITH HEAVY DUTY SQUARE TOP				
MODEL NUMBER	WT. Lbs	COVER SIZE	OUTLET SIZE	LACQUERED CAST IRON BODY WITH NB (-1) OR SS (-3)
C1102-XS	7.25	5" x 5"	2"	\$403.00
C1103-XS	6.75	5" x 5"	3"	\$421.00
C1104-XS	7.25	5" x 5"	4"	\$535.00
C1105,6-XS	8.50	5" x 5"	5", 6"	\$823.00

ANSI/ASME RATING	
COVER	LOAD RATING
5" DIA. NB	2000-4999 lbs
5" DIA. SS	5000-7499 lbs

C1100 SERIES MEETS ANSI CLEANOUT STANDARD A112.36.2M-1991

PARTS	A1 BODY	XS-1 or -3

C1200-C-R SERIES ISOLATION FLOOR CLEANOUT WITH ROUND TOP

C1200-C-R SERIES

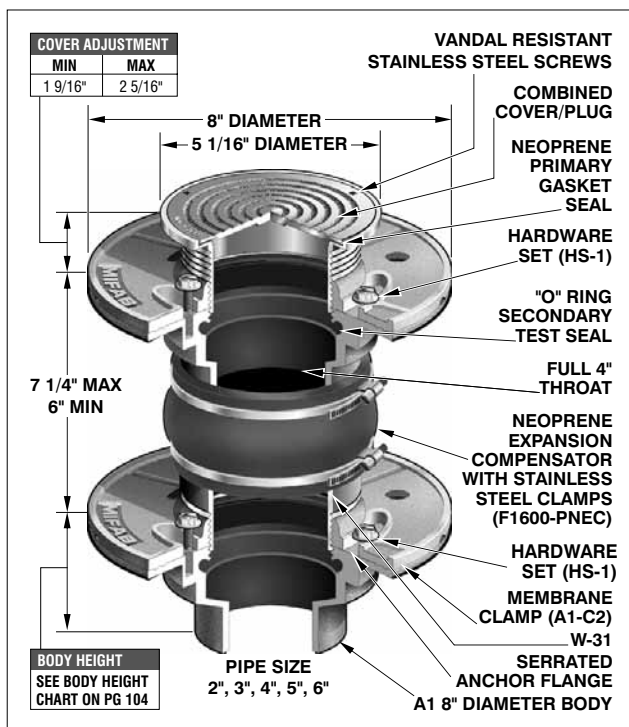

PARTS
R-1,3,4
F1600-PNEC
W-31
HS-1
A1-C2
A1 BODY

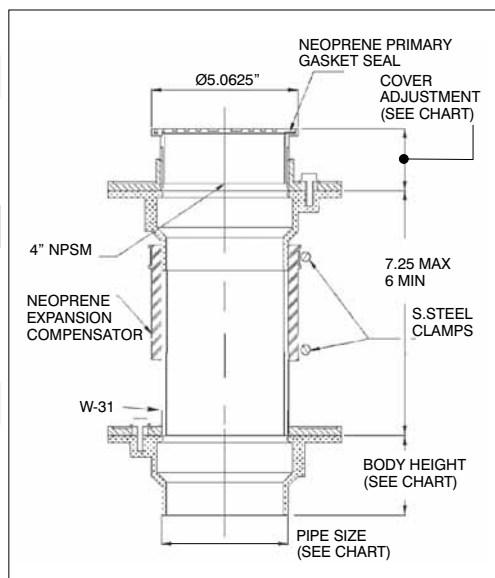

C1100 SERIES MEETS ANSI CLEANOUT STANDARD A112.36.2M-1991 SEE PAGE 108 FOR C1200-C-R OPTIONAL VARIATIONS

C1200-C-R ISOLATION FLOOR CLEANOUT WITH ROUND TOP				
MODEL NUMBER	WT. Lbs	COVER SIZE	OUTLET SIZE	LACQUERED CAST IRON BODY WITH: DUCTILE IRON (-4) NB (-1) OR SS (-3)
C1202-C-R	16.75	5" Round	2"	\$730.00 \$ 878.00
C1203-C-R	16.00	5" Round	3"	\$730.00 \$ 878.00
C1204-C-R	16.75	5" Round	4"	\$730.00 \$ 878.00
C1205,6-C-R	18.00	5" Round	5", 6"	\$888.00 \$1035.00

ANSI/ASME RATING	
COVER	LOAD RATING
5" DIA. NB	2000-4999 lbs
5" DIA. SS	5000-7499 lbs
5" DIA. DI	OVER 10,000 lbs

Design and dimensions are subject to modification. Prices do not include applicable taxes. Visit www.mifab.com for the most recent product information.

MIFAB, Inc., 1321 West 119th Street, Chicago, Illinois 60643-5109, USA

Toll Free 1-800-465-2736, Fax 773-341-3049

All sales subject to MIFAB's Terms and Warranties. Please refer to inside front cover.