

F1460 SERIES AREA DRAIN WITH 15" SQUARE ADJUSTABLE HEAVY DUTY TRACTOR GRATE

F1460 SERIES

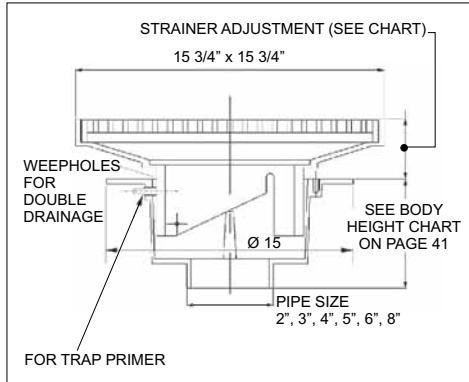
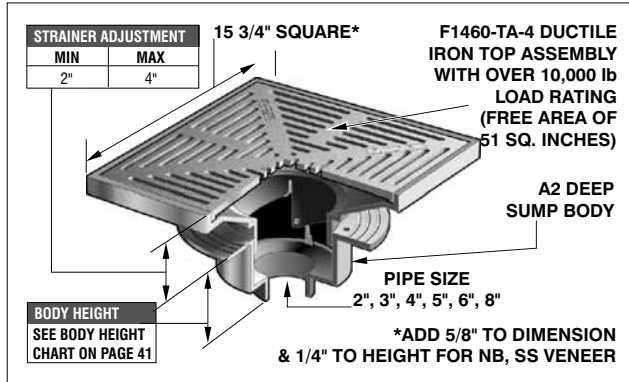

MODEL NUMBER	WT. Lbs	STRAINER DESCRIPTION	LIST PRICE LACQUERED CAST IRON BODY WITH:		
			DUCTILE IRON (-4)	NICKEL BRONZE (VENEER) (-1)	STAINLESS STEEL (VENEER) (-3)
F1462,3,4,6,8	69.00	15" x 15" Adj. tractor grate	\$1497.00	\$2193.00	\$2193.00
F1462,3,4,6,8-Y	69.00	15" x 15" Non-Adj. flat grate	\$1256.00	\$2193.00	\$2193.00

WHEN A MEMBRANE CLAMP IS REQUIRED, ADD SUFFIX (-C) NO ADD

F1440, F1450, F1460 AND F1470 OPTIONAL VARIATIONS CONTINUED FROM PAGE 38:						
SUFFIX	DESCRIPTION	F1440	F1450	F1460	F1470	
-35	SS mesh screen over bucket	P.O.A.	P.O.A.	P.O.A.	P.O.A.	
-40	Underdeck clamp (A2-C3)	\$ 124.00	\$ 124.00	\$ 124.00	\$ 124.00	
-41	Sump receiver (A2-BP)	\$ 139.00	\$ 139.00	\$ 139.00	\$ 139.00	
-90	Threaded side outlet (2", 3", 4")	\$ 190.00	\$ 190.00	\$ 190.00	\$ 190.00	
-C	Membrane clamp (A2-C3)	No Add	No Add	No Add	No Add	
-F4-(1,3)	4" NB or SS round funnel	\$ 218.00	\$ 218.00	\$ 218.00	\$ 218.00	
-F4-50	4" cast iron round funnel	\$ 91.00	\$ 91.00	\$ 91.00	\$ 91.00	
-F6-(1,3)	6" NB or SS round funnel	\$ 325.00	\$ 325.00	\$ 325.00	\$ 325.00	
-F6-50	6" cast iron round funnel	\$ 147.00	\$ 147.00	\$ 147.00	\$ 147.00	
-G-(1,3)	4" x 9" NB or SS oval funnel	\$ 454.00	\$ 454.00	\$ 454.00	\$ 454.00	
-G-50	4" x 9" C.I. oval funnel	\$ 218.00	\$ 218.00	\$ 218.00	\$ 218.00	
-J-(1,3)	3" x 1" NB or SS oval funnel	P.O.A.	P.O.A.	P.O.A.	P.O.A.	
-J-50	3" x 1" cast iron oval funnel	P.O.A.	P.O.A.	P.O.A.	P.O.A.	
P	Push on outlet (2", 3" or 4")	No Add	No Add	No Add	No Add	
T	Threaded outlet (2", 3" or 4")	\$ 40.00	\$ 40.00	\$ 40.00	\$ 40.00	
X	Inside caulk outlet (2", 3", 4")	No Add	No Add	No Add	No Add	
-Z	Extended wide elastomeric flange (20"x 20" x 1/4" thick)	P.O.A.	P.O.A.	P.O.A.	P.O.A.	
5	5" no hub outlet	\$ 284.00	\$ 284.00	\$ 284.00	\$ 284.00	
5T	5" threaded outlet	\$ 284.00	\$ 284.00	\$ 284.00	\$ 284.00	
5X	5" inside caulk outlet	\$ 284.00	\$ 284.00	\$ 284.00	\$ 284.00	

AREA DRAINS

F1470 SERIES AREA DRAIN WITH 15" SQ. ADJ. HEAVY DUTY TRACTOR GRATE & EXTRA DEEP SUMP

F1470 SERIES

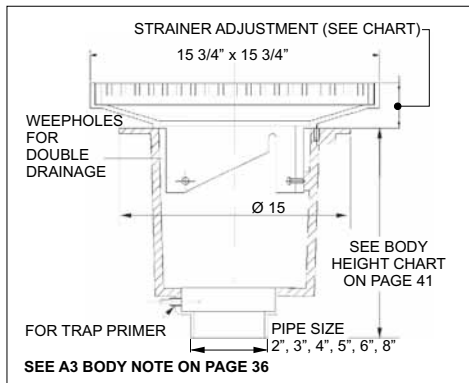
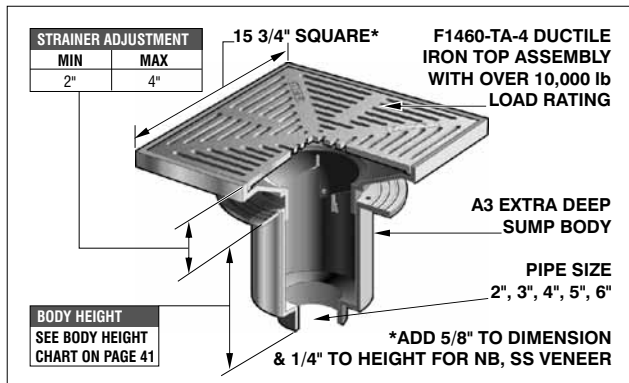

MODEL NUMBER	WT. Lbs	STRAINER DESCRIPTION	LIST PRICE LACQUERED CAST IRON BODY WITH:		
			DUCTILE IRON (-4)	NICKEL BRONZE (VENEER) (-1)	STAINLESS STEEL (VENEER) (-3)
F1472,3,4,6	75.00	15" x 15" Adj. tractor grate	\$1788.00	\$2740.00	\$2740.00
F1472,3,4,6-Y	75.00	15" x 15" Non-Adj. tractor grate	\$1788.00	\$2740.00	\$2740.00
F1472,3,4,6-Y-14	75.00	15" x 15" Non-Adj. flat grate	\$1663.00	\$2434.00	\$2434.00

WHEN A MEMBRANE CLAMP IS REQUIRED, ADD SUFFIX (-C), NO ADD

Design and dimensions are subject to modification. Prices do not include applicable taxes. Visit www.mifab.com for the most recent product information.

MIFAB, Inc., 1321 West 119th Street, Chicago, Illinois 60643-5109, USA

Toll Free 1-800-465-2736, Fax 773-341-3049

All sales subject to MIFAB's Terms and Warranties. Please refer to inside front cover.