

MWH SERIES PISTON TYPE WATER HAMMER ARRESTORS

**MWH
SERIES**

- Thick walled one piece, seamless "K" copper body. Unique design eliminates separate end cap connection to ensure maximum integrity of the body and guarantees free movement of the piston for maximum performance.
- RYTON™ PPS piston with two EPDM o-rings (Parco#5778-80) with FDA(Dow Corning™#111) approved silicone lubricant. Ribbed piston design reduces secondary shock and flared piston skirt prevents hard particles suspended in the water supply from contacting the o-rings to provide increased product life.
- Large volume air chamber provides better dampening for superior water hammer arrestor performance.



NOT RECOMMENDED FOR INSTALLATION IN HORIZONTAL OR INVERTED POSITION

SWEAT CONNECTION MODELS:

MODEL NUMBER	LIST PRICE
MWHS-A	\$ 131.00
MWHS-B	\$ 252.00
MWHS-C	\$ 374.00
MWHS-D	\$ 920.00
MWHS-E	\$1097.00
MWHS-F	\$1271.00

- Temperature range: maximum working temperature is 250 °F
- Operating pressure: Water hammer arrestors are engineered for a flowing pressure of up to 60 p.s.i. If the system pressure exceeds 85 p.s.i., a pressure reducing valve should be installed upstream of the arrestor to lower the line pressure.
- Engineered to limit the system surge pressure of 1,500 p.s.i. Tested and certified to the A.S.S.E. 1010 and ANSI A112.26.1M Standards and listed with I.A.P.M.O. **Patent # 6,539,976**

MODEL NUMBER	ASSE RATING	FIXTURE UNITS	(A) HEIGHT	(B) PIPE SIZE	(C) WRENCH FLATS	LIST PRICE
MWH-A	A	1-11	4 1/2"	1/2"	1 1/8"	\$ 119.00
MWH-B	B	12-30	6 3/4"	3/4"	1 1/8"	\$ 240.00
MWH-C	C	31-60	6 3/4"	1"	1 1/8"	\$ 362.00
MWH-D	D	61-113	10 1/2"	1 1/4"	1 3/4"	\$ 908.00
MWH-E	E	114-154	11 1/4"	1 1/2"	2"	\$1085.00
MWH-F	F	155-330	13"	2"	2 1/2"	\$1259.00

NOTE: Add \$12.00 list price to each of the above for SWT. Connection.

WHB SERIES STAINLESS STEEL BELLOWS TYPE WATER HAMMER ARRESTORS

**WHB
SERIES**

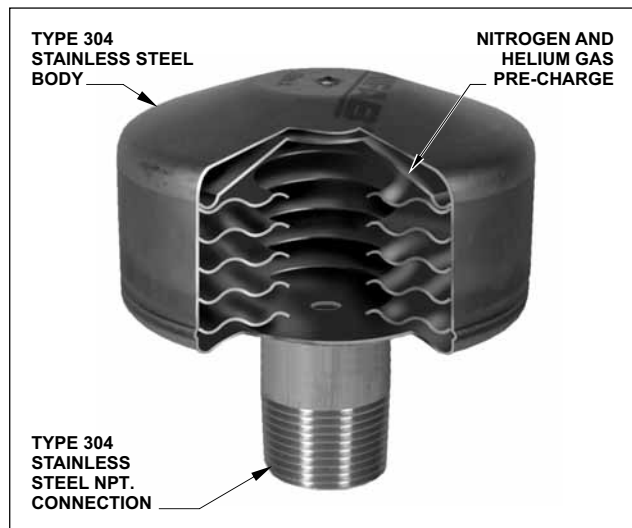
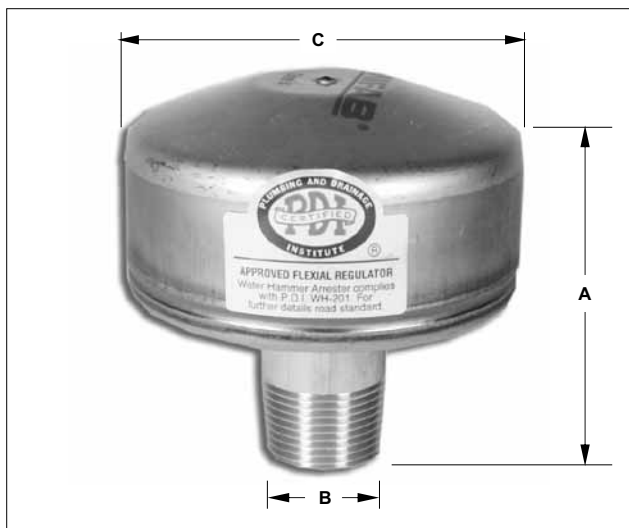

MODEL NUMBER	PDI RATING	FIXTURE UNITS	PIPE SIZE	LIST PRICE
WHB-A	A	1-11	3/4"	\$ 293.00
WHB-B	B	12-30	1"	\$ 591.00
WHB-C	C	31-60	1"	\$ 889.00
WHB-D	D	61-113	1"	\$2225.00
WHB-E	E	114-154	1"	\$2512.00
WHB-F	F	155-330	1"	\$3087.00

"A" HEIGHT	"B" CONN. SIZE	"C" DIAMETER
3 3/8"	3/4"	3 3/8"
4"	1"	3 3/8"
4 3/8"	1"	3 3/8"
5 3/8"	1"	3 3/8"
7 1/4"	1"	3 3/8"
7 1/4"	1"	3 3/8"

Design and dimensions are subject to modification. Prices do not include applicable taxes. Visit www.mifab.com for the most recent product information.

MIFAB, Inc., 1321 West 119th Street, Chicago, Illinois 60643-5109, USA

Toll Free 1-800-465-2736, Fax 773-341-3049

All sales subject to MIFAB's Terms and Warranties. Please refer to inside front cover.