

Specification: MIFAB® Series F1820 lacquered cast iron deep sump large planting area drain with anchor flange, cast iron water proofing membrane clamp ring, and low profile, self-locking aluminum dome strainer with stainless steel mesh screen.

Function: Used to drain water that accumulates in planting or flower boxes. The stainless steel mesh covered aluminum dome prevents fines from entering the drain line.

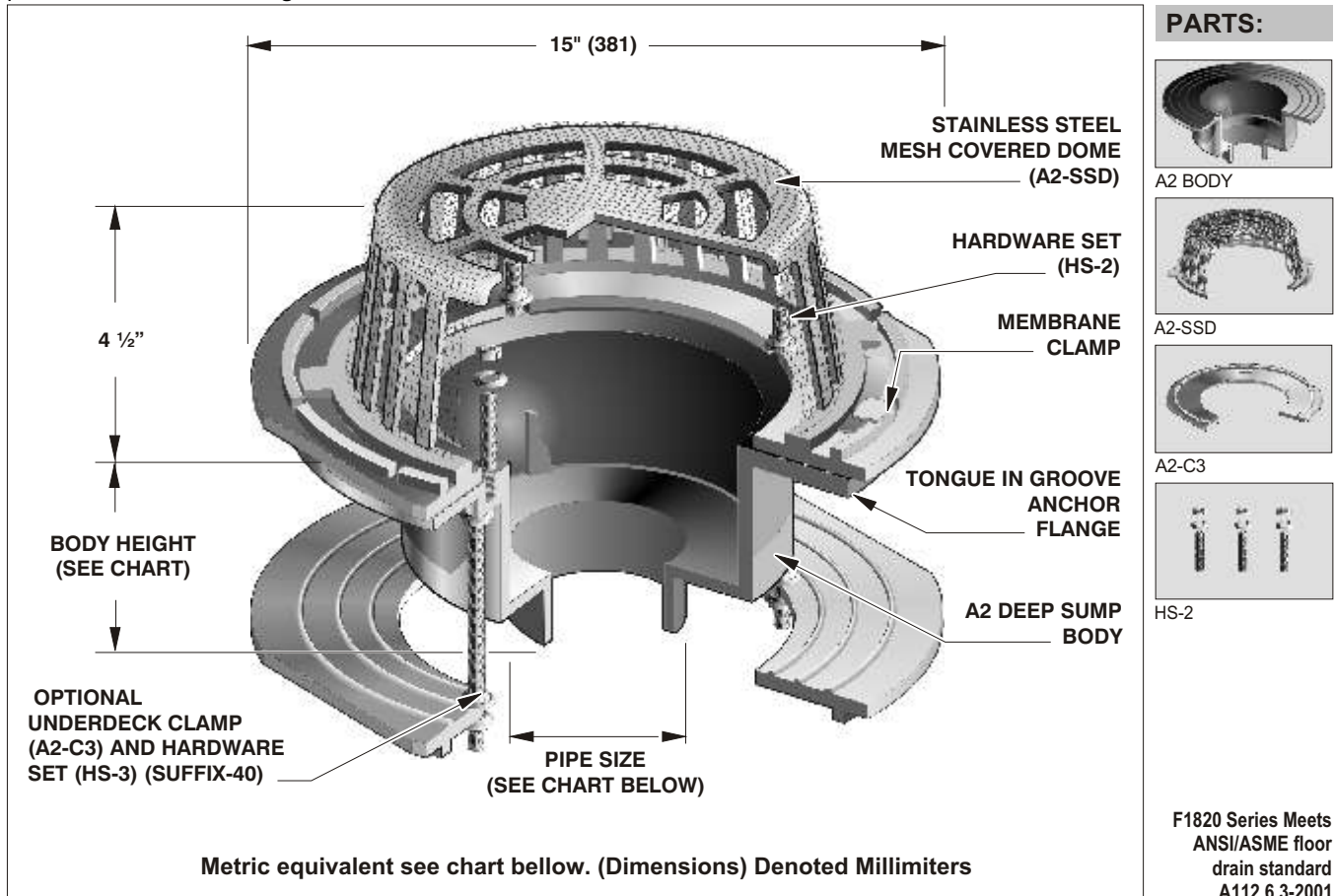

Metric equivalent see chart below. (Dimensions) Denoted Millimeters

PIPE SIZE	BODY HEIGHT				
	NO HUB (STANDARD)	PUSH ON (P)	THREADED (T)	INSIDE CAULK (X)	PVC/ABS (-30)/(-31)
2" (51)	5 7/16" (138)	6 1/8" (156)	5 7/16" (138)	6 1/4" (159)	7 1/8" (181)
3" (76)	5 7/16" (138)	6 1/8" (156)	5 7/16" (138)	6 1/4" (159)	8 1/8" (206)
4" (102)	5 7/16" (138)	6 1/8" (156)	5 7/16" (138)	6 1/4" (159)	8 1/8" (206)
5" (127)	5 7/16" (138)	-	5 7/16" (138)	6 1/4" (159)	-
6" (152)	5 7/8" (149)	8" (203)	6" (152)	6 1/4" (159)	-
8" (203)	5 7/8" (149)	-	-	5 5/8" (143)	-

- | | | | |
|---|---------------|--|---------------|
| OPTIONAL VARIATIONS: | SUFFIX | SUFFIX | SUFFIX |
| <input type="checkbox"/> 3M epoxy finish | -3M | <input type="checkbox"/> Stainless steel body (Type 304) | -28 |
| <input type="checkbox"/> Sediment bucket | -5 | <input type="checkbox"/> Stainless steel body (Type 316) | -29 |
| <input type="checkbox"/> Vandal proof dome | -6 | <input type="checkbox"/> PVC socket connection body | -30 |
| <input type="checkbox"/> Backwater valve | -8 | <input type="checkbox"/> ABS socket connection body | -31 |
| <input type="checkbox"/> Acid resistant epoxy coating | -11 | <input type="checkbox"/> Underdeck clamp | -40 |
| <input type="checkbox"/> All galvanized | -13 | <input type="checkbox"/> Sump receiver | -41 |
| <input type="checkbox"/> Extension | -15 | <input type="checkbox"/> Rough bronze dome | -81 |
| <input type="checkbox"/> Secondary flat strainer | -21 | <input type="checkbox"/> Threaded side outlet | -90 |
| <input type="checkbox"/> Bronze body | -27 | <input type="checkbox"/> No hub side outlet | -90NH |
| | | <input type="checkbox"/> 4" Round funnel | -F4 |
| | | <input type="checkbox"/> No hub outlet | (Standard) |
| | | <input type="checkbox"/> Push on outlet | P |
| | | <input type="checkbox"/> Threaded outlet | T |
| | | <input type="checkbox"/> Inside caulk outlet | X |

Job Name: _____	Page No: _____
Section No: _____	Contractor: _____
Schedule No: _____	Purchase Order No: _____