

UTS utility shelves

Our 16 gauge cold rolled steel shelves allow the rackmounting of non-rack mount equipment. One-piece construction. Finished in durable black baked enamel. Now with slotted rear return for managing cable.

Model	Depth	Height	Usable Width	Capacity
UTS-1	11"	1-3/4"	17-1/4"	30 lbs.
UTS-2	14-1/2"	3-1/2"	17-1/4"	50 lbs.
UTS-3	14-1/2"	5-1/2"	17-1/4"	80 lbs.

UTS-2

UTS-3

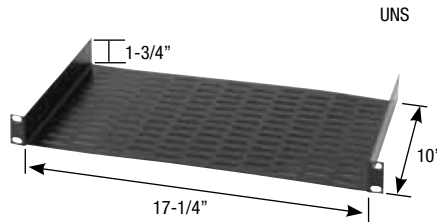

UNS universal rack shelf

One space, 14-gauge shelf has slotted-pattern in bottom for mounting a variety of half-rack equipment. Finished in durable black baked enamel.

Model	Depth	Height	Usable Width	Capacity
UNS-1	10"	1-3/4"	17-1/4"	20 lbs.

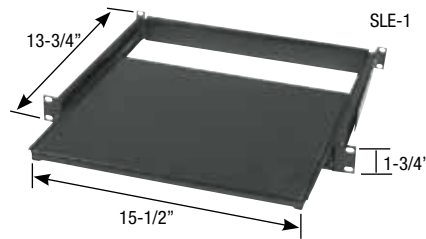

SLE economy sliding shelf

For supporting equipment up to 35 pounds. Ears attached to the rear frame allowing unit to be secured to the back of any enclosed rack. 12-inch sliders with nylon roller bearings allow for a smooth sliding movement. Shelf is black melamine.

Model	Shelf Size W x D	Height	Capacity
SLE-1	15-1/2" x 13-3/4"	1-3/4"	35 lbs.

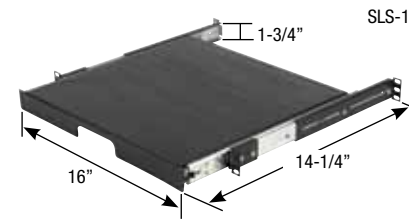

SLS-1 sliding shelf

Extra heavy duty shelf occupies just one rack space. Supports up to 100 pounds. Shelf is 14-gauge steel finished in black baked enamel. Extra heavy-duty ball bearing sliders extend a full 14". Rear rack rail required.

Model	Shelf Size W x D	Height	Capacity
SLS-1	16" x 14-1/4"	1-3/4"	100 lbs.

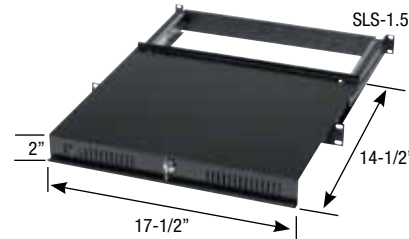

SLS 1.5 sliding shelf

Steel shelf measuring 17-1/2" W x 14-1/2" deep locks both in and out. Extending on 14 inch, full extension, ball bearing sliders and occupying one and a half rack spaces. SLS 1.5 is supported by an all steel frame and extension ears for rear support. Finished in black liquid coat.

Model	Shelf Size W x D	Height	Capacity
SLS-1.5	17-1/2" x 14-1/2"	2"	60 lbs.

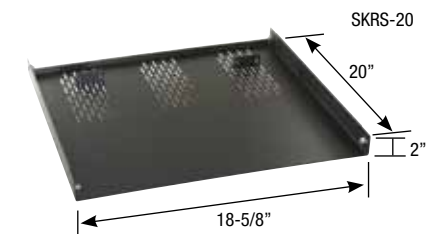

SKRS shelf

Shelf specifically designed to fit our SKR series of racks. It provides secure rackmounting for non-rackmount gear. Its unique ability to use zero space, give extensive usable shelf area and provide heavy duty weight capacity makes it a winner. Finished in black liquid coat.

Model	Usable Depth	Height	Usable Width	Capacity
SKRS-20	20"	1-1/2"	18-5/8"	250 lbs.
SKRS-26	26"	1-1/2"	18-5/8"	250 lbs.
SKRS-30	30"	1-1/2"	18-5/8"	250 lbs.

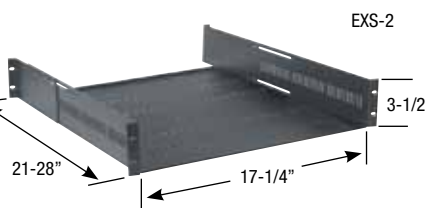

EXS extendable shelf

Combines heavy duty capacity (350lbs.) with rear support and is versatile enough to be used in all of our racks. It is fully vented and extends 21" to 28" in front to rear mounting adjustment. Usable depth is 21". Occupies 2 rack spaces. Finished in black liquid coat.

Model	Usable Depth	Height	Usable Width	Capacity
EXS-2	21"	3-1/2"	17-1/4"	350lbs.
EXS-2-16	16"	3-1/2"	17-1/4"	550lbs.

SHELVES

Model	Depth	Height	Usable Width	Capacity
WMS	16-3/4"	14"	20-3/4"	150lbs.

WMS wall mount shelf

The WMS provides a secure yet inexpensive way to mount equipment to a wall. With a vented bottom for air circulation and conduit knockouts for cable passage, this 16-gauge steel fully welded unit has a 200 pound capacity. Finished in rugged black powder coat, the WMS can also be used to house our ER or ERK series of racks.

Overall dimensions: 16-3/4" D x 20-7/8" W x 14" H

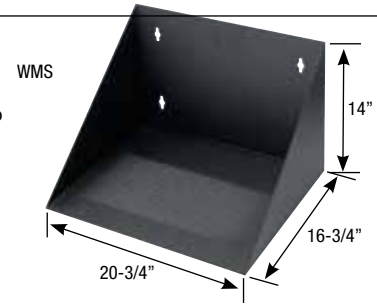

Model	Depth	Height	Usable Width	Capacity
UTVS-3-14	14"	5-1/4"	17-1/4"	80lbs.
UTVS-3-18	18"	5-1/4"	17-1/4"	80lbs.

UTVS-3 vented shelf

This 16-gauge steel shelf, finished in black powder coat will handle up to 60 pounds of equipment. It occupies 3 rack spaces and is either 14" (UTVS-3-14) or 18" (UTVS-3-18) deep. Slotted bottom allows for ventilation and slotted rear return for cable management.

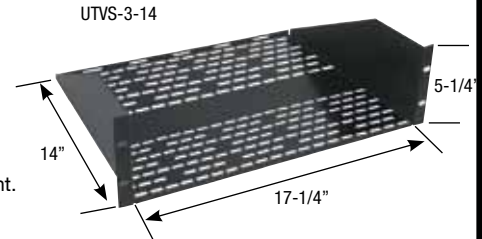

Model	Depth	Height	Usable Width	Capacity
ATS-16	16-26"	1-1/2"	17-1/4"	400lbs.

ATS-16-26 adjustable telescoping shelf

Constructed of 16-gauge cold rolled steel and finished in a durable black powder coat, the ATS shelf attaches to front and rear rack rail that are anywhere from 16 inches to 26 inches apart. Providing tremendous strength and a weight capacity of 400 lbs., the ATS is ideal for the deepest components, is fully vented and has a variety of tie off points to facilitate cable management.

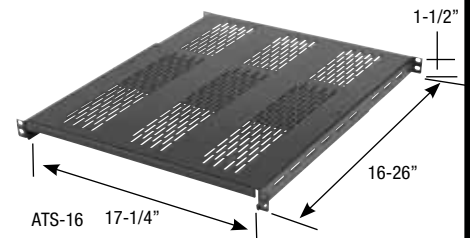

Model	Depth	Height	Usable Width	Capacity
VCS-2	18"	3-1/2"	17-1/4"	80lbs.

VCS-2 cantilevered shelf

Occupying two rack spaces, this 16-gauge steel shelf allows user to bring equipment well forward of the rack face. Vented for air circulation, this shelf is 18" deep and will support up to 80 pounds. VCS-2 features built in cable management and is finished in black powder coat.

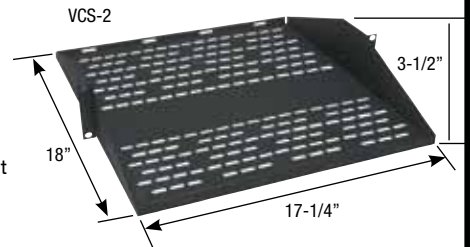

Model	Depth	Height	Usable Width	Capacity
TR-2	14-1/4"	3-1/2"	17-1/4"	50lbs.
TR-3	14-1/4"	5-1/4"	17-1/4"	80lbs.
TR-4	14-1/4"	7"	17-1/4"	100lbs.

TR trap shelf

Available in 2, 3 and 4 space versions, this versatile shelf is constructed of 16-gauge cold, rolled steel and finished in durable black baked enamel. Comes complete with 2 fully adjustable hold down bars that "trap" equipment. Bars are padded to protect the finish on your gear. Returns on the front and rear edges of shelf provide additional lateral strength.

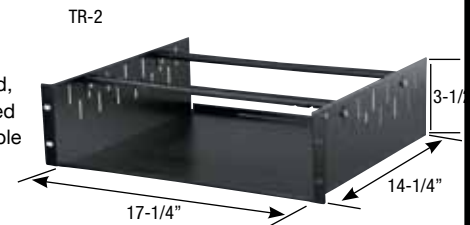

Model	Depth	Height	Usable Width	Capacity
ROTRS	17-7/8"	1-1/2"	18-7/8"	250 lbs.

ROTRS shelf

This "4 point" shelf fastens to front and rear rack rails of ROTR to provide a stable platform and unequalled support for components. Constructed of 16-gauge cold rolled steel and finished in black powder coat.

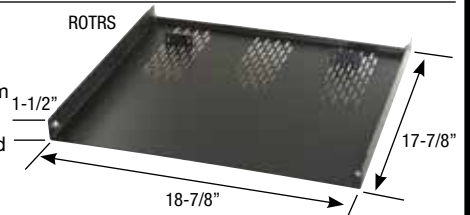

Model	Depth	Height	Usable Width	Capacity
WDS-14	14"	5-1/4"	18-5/8"	80lbs.
WDS-17	17"	5-1/4"	18-5/8"	80lbs.

WDS wide shelf

Intended for use with components wider than standard 17-3/8" inside rack measurement. Unit mounts to the 1-1/2" rack rail mounting face or into millwork. Available in 14" or 17" depths. Occupies three rack spaces. Finished in durable black baked enamel.

