



Verification of Functionality and Coverage

Toftejorg Sanitary Rotacheck

Application

Toftejorg Sanitary Rotacheck represents an important tool for increasing quality assurance in tank cleaning, since it provides an electronic means of verifying the 3D impact coverage of the Toftejorg rotary jet head. The system is appropriate wherever rotary jet heads are employed in cleaning tanks. The signal generated by the system can be audible, visual or integrated into the customer's process control specification. Toftejorg Sanitary Rotacheck is particularly suited to industries where improved verification standards are required, e.g., PAT for pharmaceutical industry, food and beverage industries.

Working principle

The Toftejorg Sanitary Rotacheck sensor is precisely installed to detect the sweep and impact of fluid jets released as the rotary jet head performs its cleaning cycle. From the geared operation of the cleaning device, and by receiving the impact force from the jets, the sensor provides verification of satisfactory operation. The Rotacheck Sensor System is self adjusted according to the tank pressure.

Cleaning Pattern

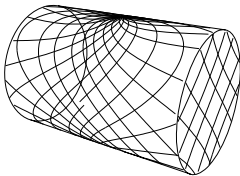

First cycle

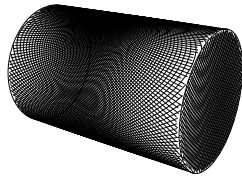

Full pattern

The above shows the cleaning pattern achieved by a Toftejorg rotary jet head. Toftejorg Sanitary Rotacheck enables the user to confirm that this operation has taken place on individual tank cleaning cycles.

Standard Design

Welding adaptor for sanitary installation. 2 and 10 m (6 and 32 ft) cable for relay connection.

Rotacheck Sensor, ATEX approved, Category 1/2 for installation in zone 0/1 and 20/21.

Relay, ATEX approved, Category 2 for installation in zone 1/21.



Materials

Sensor and diaphragm 316L (UNS S31603).
Option: Hastelloy



Technical Data

Pressure:01 - 2 bar (1.5 - 29 psi)
Max. overload pressure:15 bar (217 psi)
Max. repetition frequency:For sensor function 2 Hz
Duration of electrical pulse:Min. 1.0 sec.
Mounting:By clamping into the welding adapter or clamped directly on the Toftejorg SaniJet 20
Sensor cable:2 m / 10 m (6 ft / 32 ft) cable, Ø6 mm (0.24 inch), PVC, 2 x 0.75 mm ² shielded
Operating temperature:	-.20 to 85 °C (-4° to 185°F)
Temperature on diaphragm:Max. medium 140 °C (284°F)
Enclosure:IP 67
Electromagnetic Noise:Tested and approved according to EU EMC directive

Certificate

2.2 - 3.1.B - ATEX

Universal Relay Unit Technical data

Supply Voltage:	.24 - 115 - 230 V AC *
	50 - 60 Hz
Power consumption:	.Max. 4 VA
Enclosure:	.IP 54
Weight:	.550 g (1.21 lb)
Mounting	.By clipping onto a 35 mm standard rail to DIN/EN 50022 or by screw fixing
Operating temperature:	..-20° to 85°C (-4° to 185°F)
Max. external load, relay:	.250 V, 2A AC
PLC output:	.24 V DC, max. 50 mA
Open collector output:	.Max. 50 V DC, max. 50 mA

* DC relay are available on request

Conditions Relating to the EX-Approval

The Universal Relay must be placed outside the hazardous area, and the supply voltage for other kinds of equipment connected to the same current circuit must not exceed $U_m = 250$ VAC. When installing the Sensor, please note that the electronics in the Sensor are galvanically connected to the housing for EMC regulations, and the Sensor must not be supplied from a source other than the Universal Relay.

Application of Sanitary Rotacheck

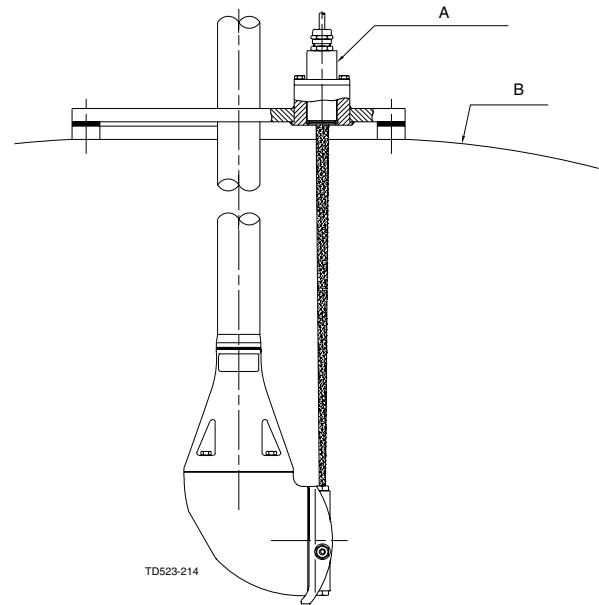

A = Rotacheck Sensor

B = Tank Top

Dimensions Installation of adaptor

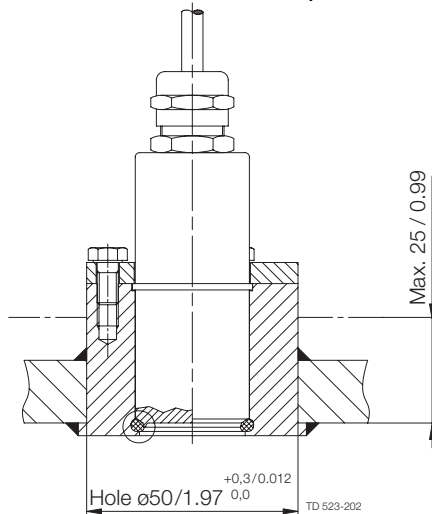

Ordering

Please specify type of cleaning head to be used and confirm application suitability.

ESE00318EN 1001

The information contained herein is correct at the time of issue, but may be subject to change without prior notice.

How to contact Alfa Laval

Contact details for all countries are continually updated on our website. Please visit www.alfalaval.com to access the information direct.