



VIDEO FURNITURE INTERNATIONAL

Furniture Designs That Communicate.

XLD, XL or Dual Plasma/LCD Stand

Model XLD XL or Dual Plasma/LCD Stand

XLD mobile stand for Single XL or dual Plasma and LCD flat panel monitors. The XLD stand is a self supporting, easy to maneuver wheeled stand with built in handles and rackmounting capability.

This unit is ideal for videoconferencing, educational teaching environments business, military, corporate training that require shared resources, just move from room to room as needed.

Accommodates single XL 52-70" or Dual 32-50" with appropriate bracket.

Standard Features Include:

- Heavy duty steel tube construction
- Scratch resistant powder coat finish
- 325lb capacity metal 5" casters with ballbearings, non-marking wheels and dustguards, 2 are locking.
- Wiring channel inside main pillars
- Adjustable height camera mount for above or below TV's
- Adjustable TV bracket height with tilt function
- Can accommodate 1XL display 52-70" with XLD-XL bracket
- Accommodates 2x 32-50" displays with XLD-D bracket
- Built in handles

Options

- XLD-D Dual Bracket 32-50" and some 52"
- XLD-XL Extra large Bracket 52-70"
- RR21 Standard 19" rackrail, 21 Units
- 9030-2/3 Metal racked shelf 2 or 3 space
- LB3 Lockbox for Codecs/Electronics
- PM-CMP- Wide camera mounting plate
- PM-CAM For camera between 2 TV's
- TVCB-Camera above left or right TV
- PM-HDCB HD Codec bracket
- PM-HD-EXP Lifesize Express/200 bracket
- PM-PB Mounted 6 outlet power bar
- Six outlet power bar with 10 ft cord
- Rack covers- for RR21 solid appearance



Shown with Options

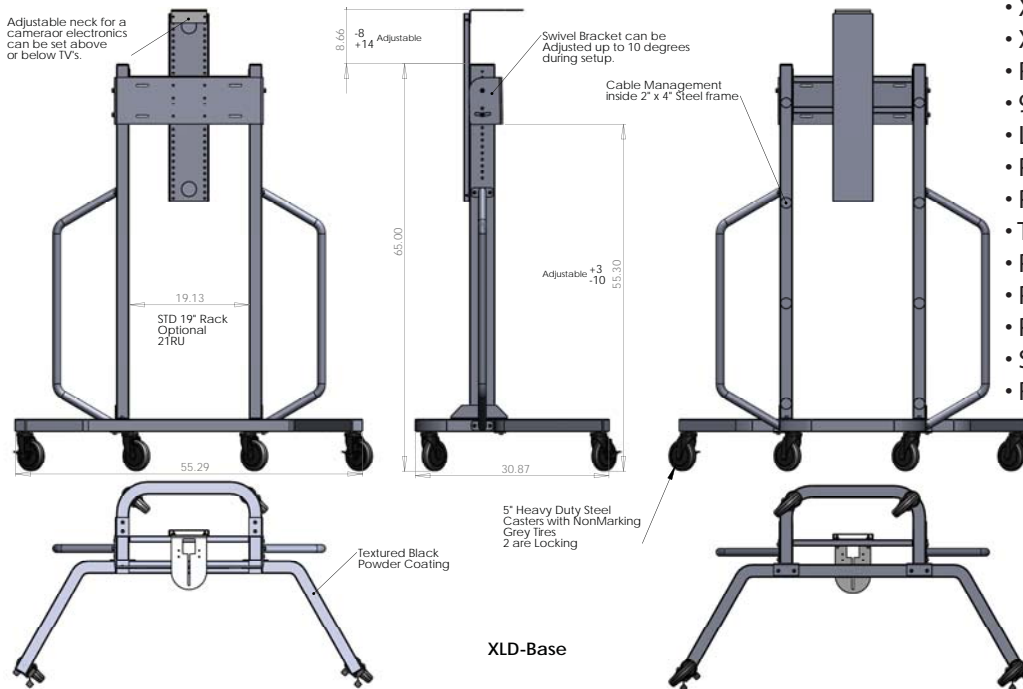

VFI can build or modify stock configurations to suit customer specifications. Please contact us to discuss how this service can help meet your needs. Some quantity restrictions may apply.

* Specification subject to change without notice.

* Computers, cameras, monitors, etc. are shown to illustrate product usage and are not included unless otherwise noted.

190 Don Hillock Drive . Aurora . Ontario . L4G 0G9

Tel: (905) 751-1459 Toll Free: (877) 834-3876 Fax: (905) 751-1488

sales@video-furn.com

www.video-furn.com