



# WATER MOTOR ALARM MODEL WM MODEL WM-2

## DESCRIPTION AND OPERATION

Globe's Model WM and WM-2 Water Motor Alarms are hydraulically operated indoor and outdoor alarms for use with fire protection systems. They are lightweight yet durable, and can be used in conjunction with alarm check, dry pipe, deluge, and preaction valves to sound a local alarm. This water-powered system eliminates the need for an electrical alarm and will operate even if electrical power is lost.

Globe's Model WM Water Motor Alarm features a one-gong system which sounds an alarm outside the building. Globe's Model WM-2 Water Motor Alarm features a unique two-gong system which provides an audible fire alarm both inside and outside the building.

The Water Motor Alarms are suitable for mounting to any type of rigid wall and can accommodate a wall thickness up to 16" (406.4 mm). They are provided with a listed and approved strainer for use in the alarm line. The Gong, Gong Mount, and Water Motor Housing are fabricated from corrosion-resistant cast aluminum. The polymer drive bearings do not require lubrication.

The WM and WM-2 utilize a lightweight, impeller design which can produce a very high decibel sound level. As water passes through the water motor, the impeller turns and the shaft rotates. The rotating shaft drives a striker assembly which rings the gong, sounding a continuous alarm as long as the water flow continues.



**MODEL WM  
WATER MOTOR ALARM**



**MODEL WM-2  
WATER MOTOR ALARM**

## APPROVALS

- cULus Listed
- FM Approved
- NYC-DOB MEA 326-91-M

## TECHNICAL DATA

- Body - cast aluminum
- Finish - red

**TYPICAL DECIBEL SOUND LEVELS - WM, WM-2**

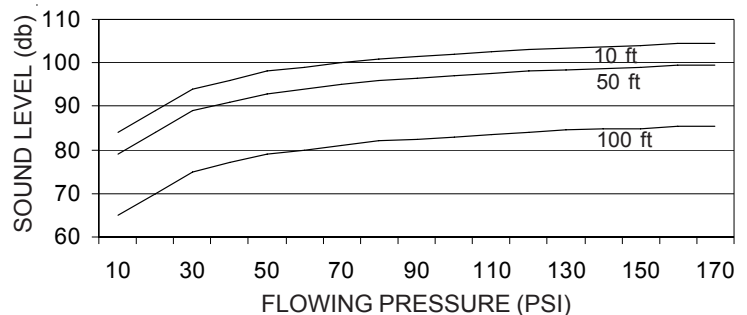

# WATER MOTOR ALARM MODEL WM MODEL WM-2

## CROSS SECTIONS

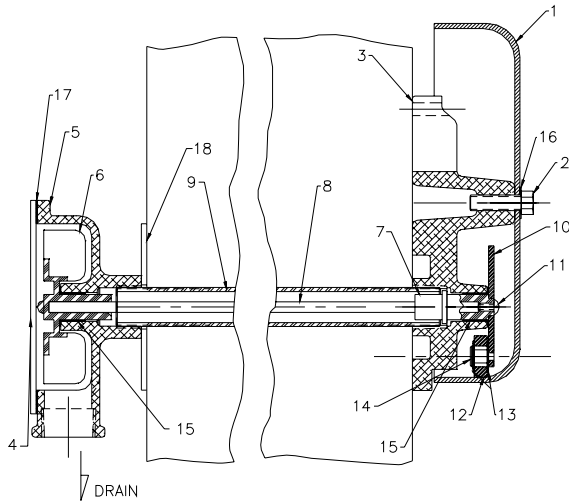

**MODEL WM**

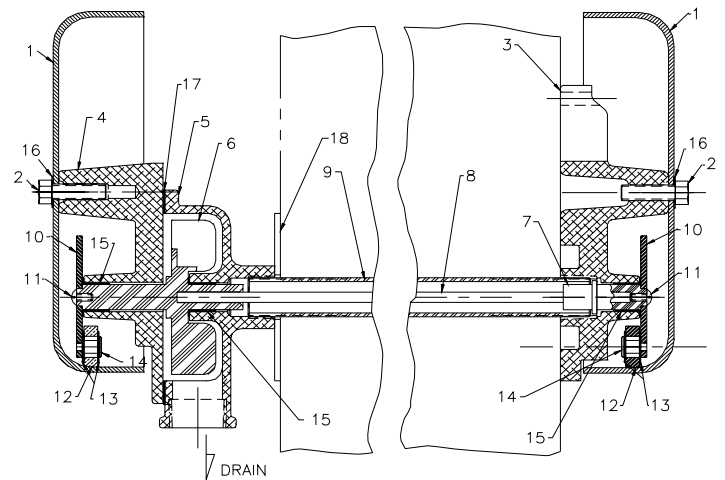

**MODEL WM-2**

ITEM	DESCRIPTION	MAT'L	WM P/N	WM-2 P/N	ITEM	DESCRIPTION	MAT'L	WM P/N	WM-2 P/N
1	Gong Shell	Aluminum	325506	325506	9	Threaded Pipe	Galvanized Pipe	325517	325517
2	Hex Head Cap Screw	Zinc	325521	325521	10	Striker Arm	Mild Steel	325510	325510
3	Gong Mounting Bracket	Aluminum	325504	325504	11	Cap Screw	Zinc Plated	325520	325520
4	Motor Cover	Aluminum	325509	-----	12	Knocker	Phenolic	325513	325513
5	Inside Gong Backing Plate	Aluminum	-----	325532	13	Knocker Retaining Washer	Stainless Steel	325516	325516
6	Impeller Housing	Aluminum	325502	325502	14	Knocker Retaining Rivet	Stainless Steel	325514	325514
7	Impeller - Inside Gong	Delrin	325507	-----	15	Bearing-Thompson	Type 6 Nylon	325518	325518
8	Drive Shaft	Aluminum	325515	325515	16	3/8 Helical Spring Lock Washer	Steel	325522	325522
					17	Backing Plate Gasket	Velumoid	325511	325511
					18	Wall Plate	Mild Steel	325528	325528

Refer to Globe's Water Motor Alarm Installation and Maintenance Guide (Bulletin WMA-1) for trim set-up, installation instructions, and maintenance.

## ORDERING INFORMATION

### SPECIFY

- Quantity • Model Number

## GLOBE® PRODUCT WARRANTY

Globe agrees to repair or replace any of its own manufactured products found to be defective in material or workmanship for a period of one year from date of shipment.

For specific details of our warranty please refer to Price List Terms and Conditions of Sale (Our Price List).



4077 AIRPARK DRIVE, STANDISH, MICHIGAN 48658

989-846-4583

1-800-248-0278

FAX 989-846-9231

www.globesprinkler.com