

AE Actuator

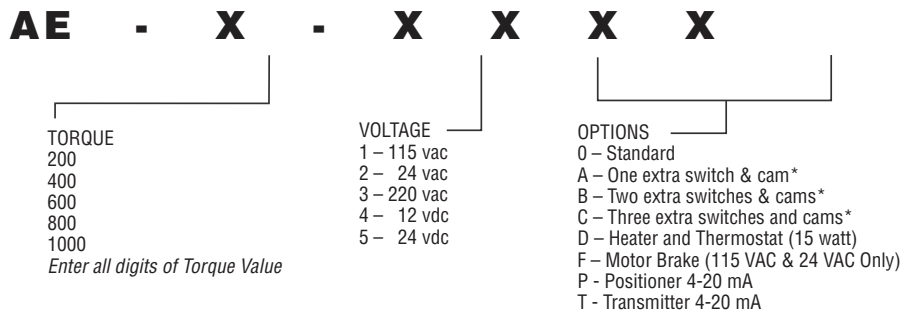

AE Series Numbering System



Note: AE will always be the first two characters of the part number, all digits from torque value must be entered into part number (i.e. 400, 1000 etc.) Only use one digit for voltage depiction (i.e. 1-5). For the options listing you may use more than one character, up to three, (i.e. O, AD or BD etc.)

AE-400-3BF : 400 lb. in.; 220 VAC; 2 extra switches and cam, motor brake
AE-1000-1D : 1000 lb. in.; 115 VAC; Heater and thermostat

Example:

- 1 Year warranty on positioner & positioner with transmitter
- Transmitter available with (P) positioner option only
- **Positioner & Transmitter are not CSA listed**
- * Not available with "P" option

AE Series Actuators



Ruggedly built and designed for easy installation, new Apollo® AE Series electric actuators deliver the most standard features and performance in their class. Now CSA listed all sizes as standard.

Five Output Torques, One Housing

- 200, 400, 600, 800 and 1,000 inch-pounds
- Long Service Life
- Newly developed anodized die cast aluminum housing
- Fiberglass reinforced nylon cover resists corrosion
- Nitrile gasket and seals cover all penetration points in housing and cover
- Precision cut and heat treated alloy spur gears
- Permanently lubricated enclosed gear train
- NEMA 4, 4X

Easy To Use

- Two separate 1/2" NPT conduit entrances for easier wiring and signal separation
- 12-position pre-wired terminal strip includes standard connections for remote open/closed position indicators; lots of room for wiring options
- Unrestricted mounting orientation
- Built-in thermal overload protection in all AC motor actuators
- Limit switches have an 11 amp rating at 115 VAC
- High visibility valve position indicator standard on all models

Many Standard Features

- Stainless steel push-and-turn manual override shaft, position indicator shaft and female output
- ISO 5211 F07 drive output reduces inventory of mounting kits
- 115 AC & 220 AC models feature a 25% duty cycle below 100°F (24AC — 20% duty cycle below 100°F)
- 12 and 24 DC — all DC voltage models provide 100% duty cycle for 1 hour after which DC motor is reduced to 80% duty cycle.
- Reversible rotation

Broad Temperature Range

- Operates from -40°F (when equipped with 15 watt heater and thermostat) to 150°F

Available Options

- Actuators can be ordered with one, two or three additional limit switches
- For low temperatures: actuators can be equipped with a thermostatically controlled heater element
- Motor brake is necessary when mounting actuator to a butterfly valve

4-20mA Positioner Features (P - Option)

Advanced Protection Features

- A) Stall Detection
 - Motor will not burn out from stalling
- B) Fault Signal
 - a. Fault LED on DHC-100 front panel
- C) Duty Cycle Protection
 - a. Allows actuators rated for 25% duty, or more, to be safely modulated
 - b. Activates prior to tripping of thermal overload protector, which prevents long shut down periods due to tripping thermal overload protector; allows the actuator to continue to move to set-point at a 25% duty cycle speed

Performance Features

- A) High Resolution ($\pm 0.1^\circ$)
 - a. 450 points of resolution on a 1/4 turn valve
- B) Dynamic Braking
 - a. Stops motor before changing actuator direction
 - b. Stops motor before mechanical brake engages, which reduces break wear
- C) Adaptive Control - Designed to maintain high resolution and accuracy by continuously monitoring and compensating for actuator backlash, motor coast, and load changes to eliminate positioner deadband

4-20mA Positioner Features (T - Option)

- A) High Resolution Feedback Transmitter
 - a. Provides voltage or mA output that can be set for any range (0 to 10 VDC in 0.0016 V steps or 0 to 20 mA in 0.0031 mA steps)
- B) Auto/Manual Station (Local Control Unit - LCU)
- C) Polarity Detection

Actuators and Controls

AE Actuator General Specifications

Actuator Model	Breakaway Torque Output (in.-lbs.)	Cycle Time 90° Travel (50% Load)	Duty Cycle	Amperage Draw (max.) Starting or locked rotor current voltage			
				115 VAC	230 VAC	12 VDC	24 VDC
AE200	200 in-lbs	5.0 sec.	25%	.74 amp	.44 amp	1.6 amp	1.7 amp
AE400	400 in-lbs	10.0 sec.	25%	.74 amp	.44 amp	1.6 amp	1.7 amp
AE600	600 in-lbs	15.0 sec.	25%	.74 amp	.44 amp	1.6 amp	1.7 amp
AE800	800 in-lbs	20.0 sec.	25%	.74 amp	.44 amp	1.6 amp	1.7 amp
AE1000	1000 in-lbs	25.0 sec	25%	.74 amp	.44 amp	1.6 amp	1.7 amp

Note: 90° Travel = Travel From Closed position to Open position or vice versa.
DC current draw is at max. torque

24 VAC current draw at locked rotor 4.6 amp

Motor	AC models: 120 VAC or 230 VAC, Reversible 3 wire, capacitor run. Self-resetting (thermal) overload protection, Class B insulation, sub-fractional horsepower. DC models: 12 VDC or 24 VDC, Reversible 2 wire, POS & NEG. No thermal overload (external circuit breaker or fuse suggested for protection.)
Lubrication	Permanently lubricated gear train and bearings
Duty Cycle	The AE-Series actuators are designed to operate at 25% duty cycle at temperatures below 100°F. See <i>Electrical Operation</i> . (24 AC-20% duty cycle below 100°F)
Temperature Operating Range	32°F to 150°F Max -40°F to 150°F with optional heater & thermostat
Thermal Protection	Self-resetting (AC Motors Only)
Conduit Connections	(2) 1/2"-NPT female
Direction Of Travel	Clockwise to Close, Counterclockwise to Open (Position indicator shaft only, manual override shaft rotates opposite)

AE Dimensions

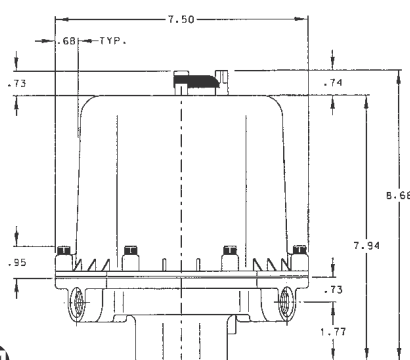
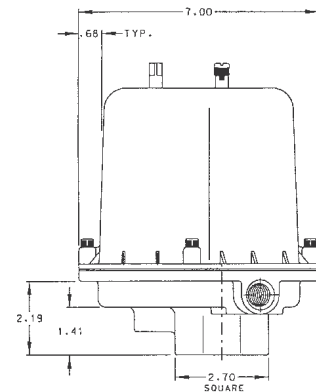
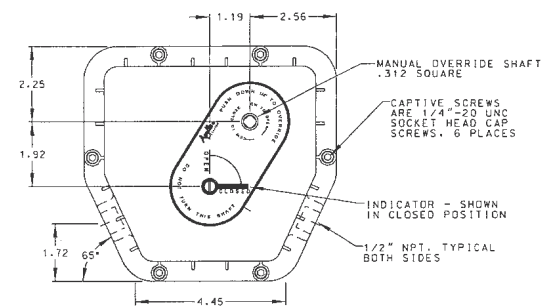

3.5" CLEARANCE (FROM TOP OF OVERRIDE SHAFT) REQUIRED FOR COVER REMOVAL

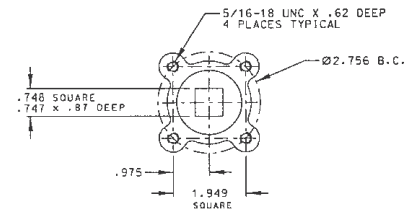

MOUNTING PATTERN ISO 5211 - F07

AE Series Actuators

