

## Fig. 282

### Universal Concrete Insert

**Size Range:** 3/8" through 7/8"

**Material:** Malleable iron body and nut

**Finish:** Plain or Galvanized

**Service:** Upper attachment for suspending pipe, shafting, motors and similar equipment from a concrete ceiling; especially suitable where rod sizes cannot be readily determined in advance.

**Approvals:** Complies with Federal Specification A-A-1192A (Type 18), WW-H-171-E (Type 18), ANSI/MSS SP-69 and MSS SP-58 (Type 18). UL, FM and ULC Approved.

**Installation:**

1. Nail insert to wooden forms.
2. Where convenient, reinforcing rods may be placed in the opening through the top of the insert, or short lengths of reinforcing rod may be wired to the insert prior to pouring concrete. However, the specified load ratings and approvals are not dependent on the use of any reinforcing rods in contact with the insert.
3. After concrete is poured and wooden forms are removed, place nut in insert and screw rod through nut until rod is firmly against the top of the insert body. The rod should not be forced against the top of the recess thereby placing unnecessary stress at the opening of the insert by the nut.

**Features:**

- Cast body prevents concrete seepage.
- Opening in top of insert provides for use of reinforcing rods up to 7/8" diameter. Sides of insert are recessed for reinforcing rods up to 1" diameter.
- Low height, broad flat bottom and widely separated nail slots minimize displacement during construction.
- The nut, held in place by V-type teeth on both insert and nut, can be raised and moved from side to side providing for lateral adjustment.
- Rod is locked in place by screwing it firmly against the top of the recess.
- One body size.

**Ordering:** Specify figure number, name, finish and size of nut.

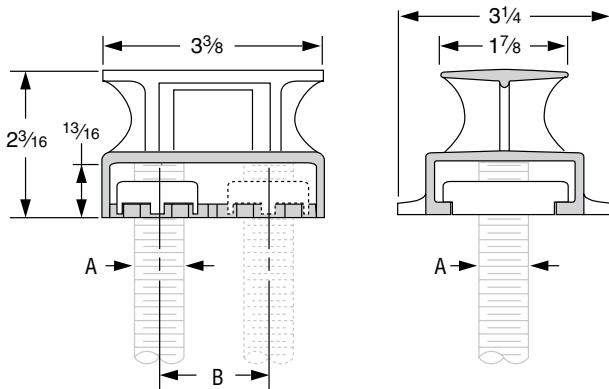
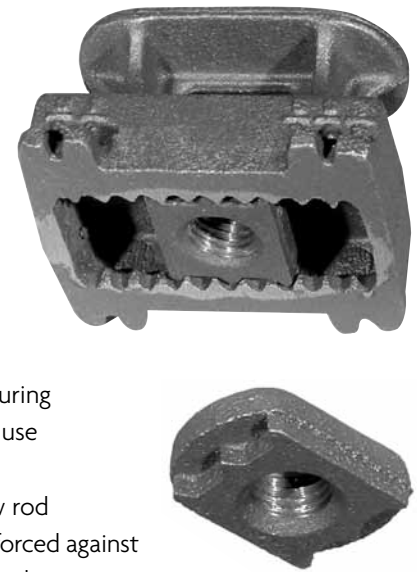

**FIG. 282 CB:  
LOAD (LBS) • WEIGHT (LBS) • DIMENSIONS (IN)**

	Rod Size A	Adjustment B	Max Load ■	Weight
<b>Insert Complete With Nut</b>	3/8	1 11/16	730	1.5
	1/2		1,130	
	5/8		1,140	
	3/4		1,140	
	7/8	1 1/8	1,140	
<b>Insert Only</b>	—	—	—	1.3
<b>Nut Only</b>	3/8	—	—	0.2
	1/2	—	—	
	5/8	—	—	
	3/4	—	—	
	7/8	—	—	

■ Based on insert and nut only. Rating is subject to the condition that the concrete used is of sufficient strength to hold the insert.

- Pictorial Table of Contents
- General Notes
- Copper Tubing Hangers
- CPVC Pipe Hangers
- Pipe Rings
- Clevis Hangers
- Steel Pipe Clamps
- Socket Clamps
- Beam Clamps
- Structural Attachments
- Brackets
- Ceiling Plates & Flanges
- Concrete Inserts & Attachments
- Hanger Rods
- Rod Attachments
- Bolts, Nuts, Pins & U-Bolts