



**RESIDENTIAL
AUTOMATIC SPRINKLERS
MODELS GL4147 & GL4947
ADJUSTABLE CONCEALED PENDENT**

DESCRIPTION AND OPERATION

The Globe Models GL4147 and GL4947 Residential Adjustable Concealed Pendent Sprinkler have a low profile yet durable design that utilizes a 3mm frangible glass ampule as the thermosensitive element. They feature economy, aesthetics and low water flow with 1/2" of adjustment. The combination of the 3mm frangible glass ampule and specially designed deflector make the Models GL4147 and GL4947 Residential Adjustable Concealed Pendent Sprinklers the ultimate in life safety and fire control. They have met the strict requirements of Underwriters Laboratories Inc. as described in UL Standard, 1626, for Residential Sprinklers for Fire Protection Service, and should be used accordingly. These sprinklers should also be installed in accordance with the appropriate NFPA Standard 13, 13D or 13R and under the direction of the approving authorities having jurisdiction.

Globe's Residential Adjustable Concealed Pendent Sprinkler consists of our pendent residential type sprinkler concealed from view by a 1" deep dome shaped ceiling plate. All that is seen at the ceiling is the 3 5/16" diameter ceiling plate color finished to match the specifier's exact requirements. The ceiling plate is soldered to the sprinkler's special upper support assembly in three places. Upon the application of sufficient heat, the plate falls to the floor exposing the residential pendent spray sprinkler. At the prescribed temperature the internal pressure within the ampule exceeds the strength of the glass causing the glass to shatter. This results in water discharge which is distributed in an approved pattern.

TECHNICAL DATA

- See reverse side for Approvals and Specifications.
- Temperature Rating - 155°F (68°C).
- Water Working Pressure Rating - 175 psi (12 Bars).
- Factory tested hydrostatically to 500 psi (34 Bars).
- Maximum low temperature glass bulb rating is -67°F (-55°C).
- Frame - bronze • Deflector - brass • Screw - brass
- Bulb seat - copper • Spring - nickel alloy • Seal - teflon
- Bulb - glass with alcohol based solution, 3mm size.
- Cover Plate - brass
- Upper Escutcheon Assembly - steel



**RESIDENTIAL
CONCEALED PENDENT**

• SPRINKLER TEMPERATURE RATING/CLASSIFICATION and COLOR CODING

CLASSIFICATION	AVAILABLE SPRINKLER TEMPERATURES	BULB COLOR	N.F.P.A. MAXIMUM CEILING TEMPERATURE
ORDINARY	155°F 68°C	RED	100°F 38°C

RESIDENTIAL AUTOMATIC SPRINKLERS MODELS GL4147 & GL4947 ADJUSTABLE CONCEALED PENDENT SPECIFICATIONS AND APPROVALS

SIN MODEL	K FACTOR	THREAD SIZE	LENGTH	FINISHES	155°F (68°C) SPRINKLER WITH 135°F (57°C) PLATE	cULus	NYC - DOB MEA 101-92-E
GL4147	4.1 (58 metric)	1/2" NPT	3" (7.6 cm)	Bright Chrome White Painted Satin Chrome ¹ Bright Brass ¹ Other Painted Finishes ¹	X	X	X
GL4947	4.9 Nominal (68 metric)						

NOTE: METRIC CONVERSIONS ARE APPROXIMATE.

¹FINISHES AVAILABLE ON SPECIAL ORDER.

INSTALLATION DATA CONCEALED PENDENT

MODEL	MAXIMUM AREA OF COVERAGE	MINIMUM WATER DISCHARGE & PRESSURES NEEDED PER SPRINKLER *
GL4147	12' x 12'	11 G.P.M. - 7.2 P.S.I.
	14' x 14'	15 G.P.M. - 13.4 P.S.I.
	16' x 16'	15 G.P.M. - 13.4 P.S.I.

CONCEALED PENDENT

GL4947	12' x 12'	13 G.P.M. - 7 P.S.I.
	14' x 14'	14 G.P.M. - 8.2 P.S.I.
	16' x 16'	14 G.P.M. - 8.2 P.S.I.
	18' x 18'	17 G.P.M. - 12 P.S.I.
	20' x 20'	20 G.P.M. - 16.7 P.S.I.

*WHEN THESE SPRINKLERS ARE USED IN NFPA 13 SYSTEMS, A 0.1 DESIGN DENSITY MINIMUM SHALL BE UTILIZED.

CROSS SECTION

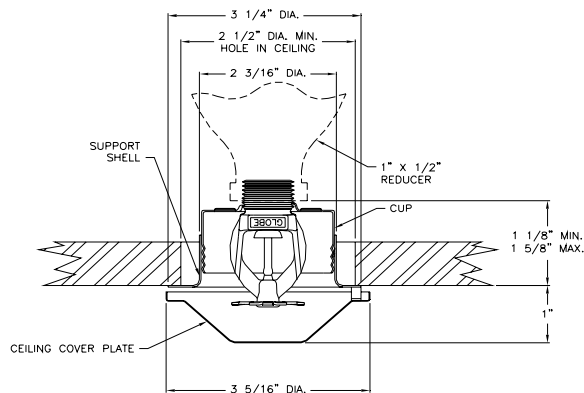

1/2" ADJUSTMENT

ORDERING INFORMATION

SPECIFY

- Quantity • Model Number • Style
- Orifice • Temperature • Finishes desired
- Quantity - Concealed Wrenches - P/N 325391
- Quantity - Protective Caps - P/N 327119

GLOBE® PRODUCT WARRANTY

Globe agrees to repair or replace any of its own manufactured products found to be defective in material or workmanship for a period of one year from date of shipment.

For specific details of our warranty please refer to Price List Terms and Conditions of Sale (Our Price List).



JANUARY 2009

4077 AIRPARK DRIVE, STANDISH, MICHIGAN 48658

989-846-4583

FAX 989-846-9231

1-800-248-0278

www.globesprinkler.com

PRINTED U.S.A.

BULLETIN GL4147/GL4947, REV. #4