

PSP1 Plug-in Special Purpose Supervisory Switch



Models Available

PSP1	Plug-in Special Purpose Supervisory Switch
PSP1A	Plug-in Special Purpose Supervisory Switch (ULC/Canadian)



Product Overview

Monitors non-rising stem gate and ball and angle valves

NEMA 3 rated enclosures

360° mounting design provides greater installation flexibility

Adjustable length supervisory cord

Lockout feature ensures alarm signal integrity

Cover tamper switch factory installed

Tamper-resistant cover screws

System Sensor's PSP1 plug-in switch is a special application supervisory switch designed for applications where no other type of listed valve supervisory switch can be used.

Application Flexibility. The PSP1 is to be used on non-rising stem gate valves and ball and angle valves. The unit is approved for Class A and Class B circuits.

Robust Construction. The PSP1 consists of a rugged rain tight metal housing. With its NEMA 3 rated housing and water-resistant cord, the PSP1 may be used in either indoor or outdoor applications.

Simplified Operation. The PSP1 features a 360° versatile mounting design and an adjustable length cord which allow more freedom to install the unit at the most desirable alignment angle.

Reliable Performance. The PSP1 employs a supervisory cord which, when pulled out, closes a set of normally open contacts. A lockout feature prevents reinsertion of the cord until the cover is removed, and the unit is reset. Removal of the cover or cutting of the cord results in an open circuit.



Engineering Specifications

Model shall be a model number PSP1 special purpose supervisory switch as manufactured by System Sensor. The unit is not intended or designed for ordinary usage. It is a special application device to be used for unusual conditions where no other approved or listed method of protection is available or practical, such as non-rising stem gate valves. When installed on a non-rising stem gate valve, turning the valve wheel will pull the plug out of the jack and close a set of normally open contacts. A lockout will prevent reinsertion and will require removal of the cover. Tamper-proof screws are provided for the cover. Removal of the cover, cutting of the cord, or ground faults will cause an open circuit. The device should be wired to the trouble circuit of a fire alarm control panel. The PSP1 shall be capable of operating on Class A or Class B circuits. The PSP1 shall be NEMA 3 rated for indoor/outdoor use and shall have an operating temperature range of -4°F to 149°F (-20°C to 65°C). The PSP1 shall be listed by Underwriters Laboratories and Underwriters Laboratories of Canada, Inc. and shall be Factory Mutual approved.

Standard Specifications

Operating Voltage
6/12/24V AC/DC

Maximum Operating Current
250 mA

Dimensions
4³/₄"L x 3"W x 2¹/₂"D
(12cm x 7.5cm x 5.6cm)

Dimensions with bracket
8¹/₂"L (21.5cm)

Operating Temperature Range
-4°F to 149°F (-20°C to 65°C)

Enclosure Rating
NEMA 3 UL Indoor/Outdoor Rated

Cover Tamper Switch
Standard

Cable
2 wire, 16 gauge waterproof, 8 feet long (2.4m)

Shipping Weight
1.7 lbs. (0.8 kg)

Warranty
3 years

PSP1 Wiring: Single Device Class B

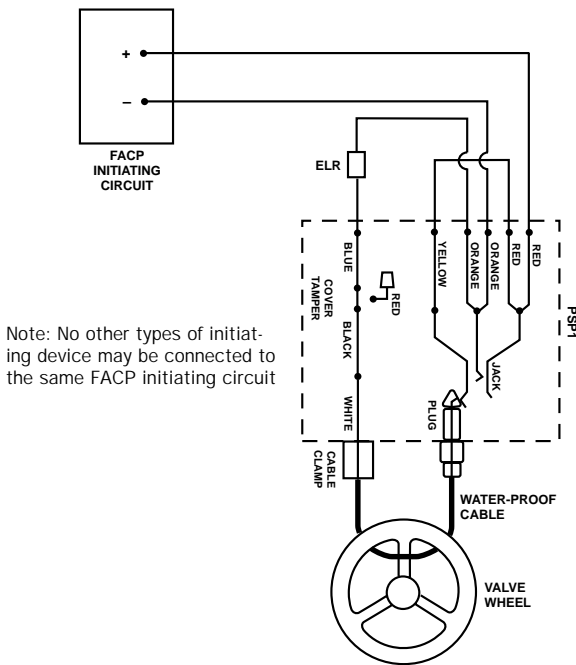

PSP1 Wiring: Single Device Class A

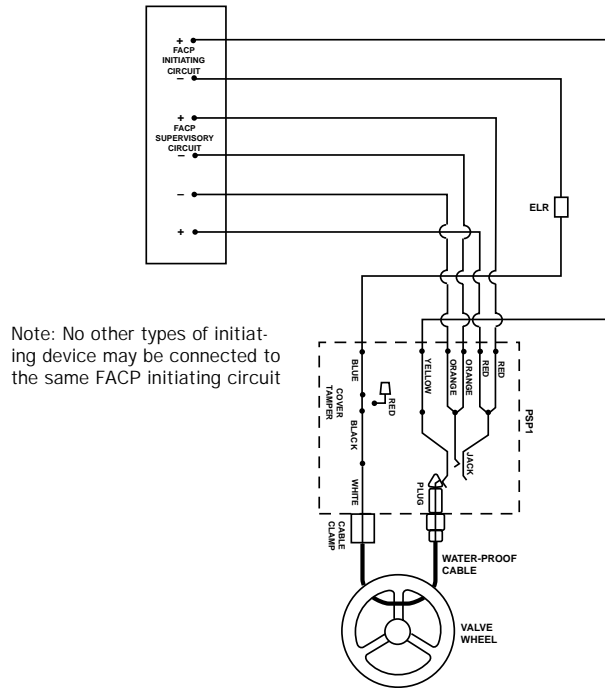

Ordering Information

Model Number	Description
PSP1	Plug-In Special Purpose Supervisory Switch
PSP1A	Plug-In Special Purpose Supervisory Switch (ULC model)

System Sensor Sales and Service

System Sensor Headquarters
3825 Ohio Avenue
St. Charles, IL 60174
Ph: 800-SENSOR2
Fx: 630/377-6495
Documents on Demand
1-800-736-7672 x3
www.systemsensor.com

System Sensor Canada
Ph: 905.812.0767
Fx: 905.812.0771

System Sensor Europe
Ph: 011.44.1403.276500
Fx: 011.44.1403.276501

System Sensor in China
Ph: 011.86.29.524.6253
Fx: 011.86.29.524.6259

System Sensor in Singapore
Ph: 011.65.273.2230
Fx: 011.65.273.2610

System Sensor- Far East
Ph: 011.85.22.191.9003
Fx: 011.85.22.736.6580

System Sensor- Australia
Ph: 011.613.54.281.142
Fx: 011.613.54.281.172