

Fig. 800 - Adjustable Sway Brace Attachment to Steel

Size Range — 4" thru 18" beam width

Material — Carbon Steel

Function — Seismic brace attachment to steel.

Features — This product's design incorporates a concentric attachment point which is critical to the performance of structural seismic connections. NFPA 13 indicates the importance of **concentric** loading of connections and fasteners. Permits secure connection to steel where drilling and/or welding of brace connection could present structural issues.

Installation Instructions — The Fig. 800 is the structural attachment component of a longitudinal or lateral sway brace assembly. It is intended to be combined with a TOLCO transitional attachment, "bracing pipe" and a TOLCO "braced pipe" attachment to form a complete bracing assembly. NFPA 13 and/or OSHPD guidelines should be followed.

To Install — Place the Fig. 800 on the steel beam, tighten the cone point set bolts on flange until bolt heads break off. Tighten hex head bolts into clamp body until lock washers are fully flat. Attach other TOLCO transitional attachment fitting, Fig. 909, 910, 980 or 986. Transitional fitting attachment can pivot for adjustment to proper brace angle.

Approvals — Underwriters Laboratories Listed in the USA (**UL**) and Canada (**cUL**). Approved by Factory Mutual Engineering (**FM**). Included in our Seismic Restraints Catalog approved by the State of California Office of Statewide Health Planning and Development (**OSHPD**). For additional load, spacing and placement information relating to OSHPD projects, please refer to the TOLCO Seismic Restraint Systems Guidelines.

Finish — Plain

Note — Available in Electro-Galvanized and HDG finish.

Order By — Figure number, type number and size number.



Component of State of California OSHPD Approved Seismic Restraints System

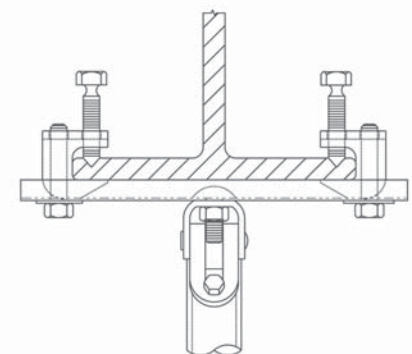
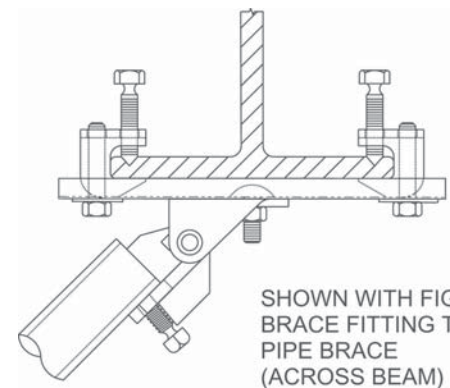
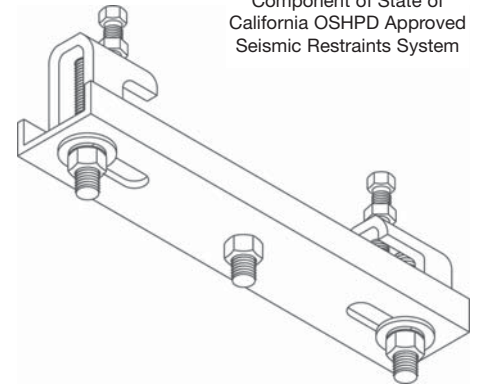

Dimensions • Weights

Size	Fits Beam Range (In.)	Max. Design Loads/Lbs. (cULus)		Max. Design Load Lbs. (FM)*	
		Along Beam	Across Beam	Along Beam	Across Beam
1	4 - 6	1265	2015	2800	2800
2	6 - 8	1265	2015	2800	2800
3	8 - 10	1265	2015	2800	2800
4	10 - 12	1265	2015	2800	2800
5	12 - 14	1265	2015	2800	2800
6	14 - 16	1265	2015	2800	2800
7	16 - 18	1265	2015	2800	2800

Dimensions • Weights

Type	Flange Thickness Max. (In.)	Max. Design Loads/Lbs. (cULus)		Max. Design Load Lbs. (FM)*	
		Along Beam	Across Beam	Along Beam	Across Beam
1	3/4	1265	2015	2800	2800
2	1 1/4	1265	2015	2800	2800

* Load shown is allowable with brace installed, between 30° - 90°.

TOLCO® brand bracing components are designed to be compatible **ONLY** with other TOLCO® brand bracing components, resulting in a Listed seismic bracing assembly. **DISCLAIMER** — NIBCO does **NOT** warrant against the failure of TOLCO® brand bracing components, in the instance that such TOLCO® brand bracing components are used in combination with products, parts or systems which are not manufactured or sold under the TOLCO® brand. NIBCO shall **NOT** be liable under any circumstance for any direct or indirect, incidental or consequential damages of any kind, including but not limited to loss of business or profit, where non-TOLCO brand bracing components have been, or are used.