

Models: 125F-CS*, 125F-SS

Cast Carbon or Stainless Steel Flanged End Simplex Basket Strainers Sizes: 3/4" - 18" (20- 450mm)

Pressure / Temperature – Non-Shock		
Model	Material	Rating
125F-CS	Carbon Steel	285psi @ -20°F to 100°F
		19.65 bar @ 37.78°C
		150psi @ 565°F 10.34 bar @ 296.11°C
125F-SS	Stainless Steel	275psi @ -20°F to 100°F
		18.96 bar @ 37.78°C
		150psi @ 565°F 10.34 bar @ 296.11°C

Max. temp. can be limited by O-ring Material. Consult factory.
 All units with knob type closure.

125F-CS Carbon Steel Class 150

125F-SS Stainless Steel Class 150



Model 125F

* Model 125F supersedes model 195, which is available upon request.

Strainers provide economical protection for costly pumps, meters, valves, and other similar mechanical equipment by straining foreign matter from the connected piping system. Installation of a strainer before mechanical equipment can ensure trouble free service and avoid costly shutdowns for repair or replacement of equipment damaged by foreign matter. The size of the perforation or mesh in the basket screen will determine the smallest particles captured. See Strainer Information section of Mueller Steam Specialty Engineering binder for detailed information including sizes and materials available.

Typical Service

- These strainers can be specified for many applications in chemical processes, including brine, paint, fuel oil, organic and inorganic chemicals, as well as condensers and heat exchangers, to name just a few.

Features

- Designed for large capacity straining and ease of maintenance.
- Cover is secured with quick-opening knobs to minimize service time.
- O-ring seals on both the cover and baskets can usually be re-used after service, no need to clean gasket residue and replace costly gaskets.
- Machined basket seat eliminates particle bypass.

Construction

- Standard cover has O-ring seal and quick release knob fasteners up to 8" size, bolted cover for sizes 10" and up
- Bolted cover available on all sizes, consult factory
- Swing clamp covers are available, consult factory
- Plugged NPT connection is provided at location D. See next page.

Capacity

- Minimum 6 to 1 ratio

Special Coatings and Treatments

- Epoxy and other corrosion resistant coatings are available on Carbon Steel, consult factory
- Pickling and passivation are available on Stainless Steel, consult factory.

Steam Jacketing

Available on request, consult factory.

Baskets

MODEL	SIZES	STANDARD (WATER)		STEAM (Recommendation)	
		MATERIAL	OPENING	MATERIAL	OPENING
125F-CS	3/4" - 4"	304SS	.062 perf	304SS	.045 perf
125F-SS	5" and Up	304SS	.125 perf	Consult Factory	

Job Name _____
 Job Location _____
 Engineer _____
 Approval _____

Contractor _____
 Approval _____
 Contractor's P.O. No. _____
 Representative _____

Materials

	125F-CS	125F-SS
Body	Carbon Steel ASTM A216 Grade WCB	Stainless Steel ASTM A351 Grade CF8M
Cover	Carbon Steel ASTM A216 Grade WCB	Stainless Steel ASTM A351 Grade CF8M
O-Ring	Buna-N	Viton®

Pressure Drop

See Pressure Drop Charts in Technical Data section of the Mueller Steam Specialty Engineering binder.

Dimensions and Weights

SIZE		DIMENSIONS								WEIGHT			
		A		B		C		D (NPT)		E Screen Removal		Carbon Steel & SS	
in.	mm	in.	mm	in.	mm	in.	mm	in.	mm	in.	mm	lbs.	kg.
¾	20	5 ¹ / ₁₆	145	4 ¹ / ₁₆	119	2 ³ / ₄	70	¾	10	5 ⁷ / ₈	150	10	4.5
1	25	5 ¹ / ₁₆	145	4 ¹ / ₁₆	119	2 ³ / ₄	70	¾	10	5 ⁷ / ₈	150	10	4.5
1¼	32	6 ¹⁵ / ₁₆	176	6½	165	3	76	½	15	8 ⁷ / ₈	206	16	7
1½	40	6 ¹⁵ / ₁₆	176	6½	165	3	76	½	15	8 ⁷ / ₈	206	16	7
2	50	9	229	7 ⁷ / ₈	200	3 ⁵ / ₈	92	¾	20	10 ¹ / ₈	257	25	11
2½	65	10 ³ / ₈	264	8 ³ / ₄	222	4	102	1	25	11 ⁷ / ₁₆	291	41	18
3	90	11 ³ / ₄	298	11 ³ / ₈	289	4½	114	1	25	14 ¹³ / ₁₆	376	65	29
4	100	15	381	15 ⁷ / ₈	403	5 ³ / ₄	146	2	50	19 ⁷ / ₈	505	135	61
5	125	18 ³ / ₈	467	18 ³ / ₈	467	7 ⁷ / ₁₆	189	1½	40	25 ⁵ / ₁₆	650	190	86
6	150	20 ¹ / ₄	514	22 ³ / ₈	568	8 ³ / ₁₆	208	2	50	29 ¹ / ₈	740	270	122
8	200	27 ³ / ₈	695	27 ³ / ₄	705	9 ³ / ₁₆	233	2	50	29 ¹ / ₈	943	497	225
10	250	29½	749	35 ⁵ / ₁₆	897	12 ⁷ / ₁₆	316	2	50	50 ³ / ₁₆	1291	1200	544
12	300	33 ³ / ₄	857	43 ³ / ₈	1114	10 ³ / ₄	273	2	50	61¼	1556	1134	515
14	350	47 ¹ / ₈	1197	34 ³ / ₈	873	20 ³ / ₈	524	2	50	69	1753	1550	522
16	400	47 ¹ / ₈	1197	34 ³ / ₈	873	20 ¹ / ₁₆	510	2	50	69	1753	1600	727
18	450	49½	1257	58	1381	16	406	2	50	82	2083	2850	1295

Apply for Certified Drawings.

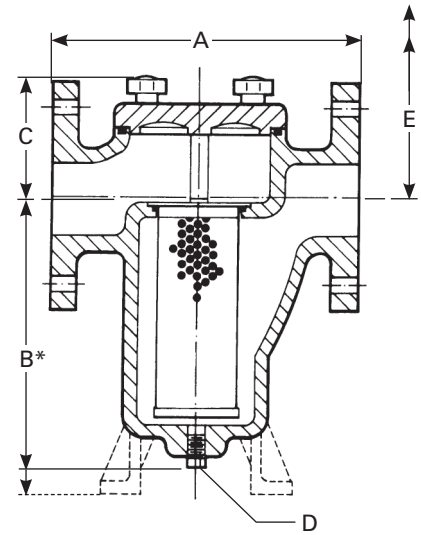

Model 125F

* "B" dimension includes the floor supports on 4" size and larger

Mueller Steam Specialty product specifications in U.S. customary units and metric are approximate and are provided for reference only. For precise measurements, please contact Mueller Steam Specialty Technical Service. Mueller Steam Specialty reserves the right to change or modify product design, construction, specifications, or materials without prior notice and without incurring any obligation to make such changes and modifications on Mueller Steam Specialty products previously or subsequently sold.



A Watts Water Technologies Company

ES-MS-125FCS_125FSS 1020

USA: St. Pauls, NC • Tel. 1-800-334-6259 • Fax 1-800-421-6772 • www.muellersteam.com



© 2010 Mueller Steam Specialty