

Kerotest KMP1 & KMP2 Static Pressure Manifolds

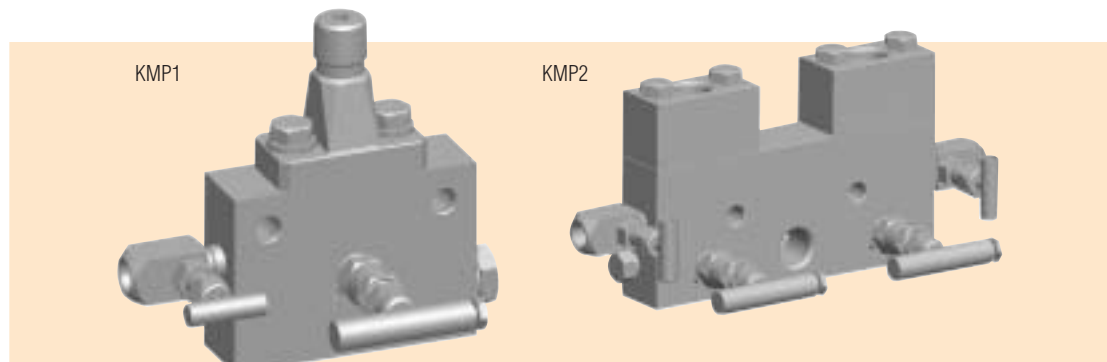

Product Brief

The KMP1 is a two-valve manifold used primarily for single instrument applications such as test, calibration, block and bleed and instrument zeroing. The KMP1 functions both as the manifold valve and also as the mount for the instrument, all in the same unit. The KMP2 manifold provides the same functions as the KMP1 except two different instruments may be installed simultaneously and both supplied from a single pressure source. It has dual block and bleed valves serving the exact same functions as the KMP1 manifold, except for two instruments rather than one. The KMP2 manifold also serves as the mount for two instruments. The pressure instruments are connected to either manifolds via 1/2-inch FNPT or 1/2-inch MNPT union connectors.

Features/Benefits

- **Bubble-tight shutoff.** Every valve is 100% tested.
- **Space-saving design.** One compact valve replaces two or four valves. Fewer connections means less leak paths means less fugitive emissions.
- **Cost-saving design.** Less parts means lower cost in the order of 25-30% compared to conventional two-valve installation.
- **Stem threads** isolated from the process fluid, eliminating process fluid contamination, lubricant washout and thread corrosion.
- **Stem end “ball” design** ensures the stem will not rotate against the body seat, eliminating seat galling, improving seat tightness and extending the life of the valve.
- **Mirror finish stems** enable smooth stem operation and extended packing life.
- **The KMC mounting** arrangement provides for secure mounting of the instrument to the manifold.
- **Rolled threads** on the stem and in the bonnet increase strength, reduce galling and extend the service life of the valve.
- **Adjustable packing** adjusts easily, increasing valve life and reducing downtime for packing replacement.
- **Multiple packing options** available including Teflon® and GRAFOIL®.



An Employee Owned Total Quality Management Company

Kerotest KMP1 & KMP2 Static Pressure Manifolds

Specifications

KMP1 Dimensions in Inches (mm)

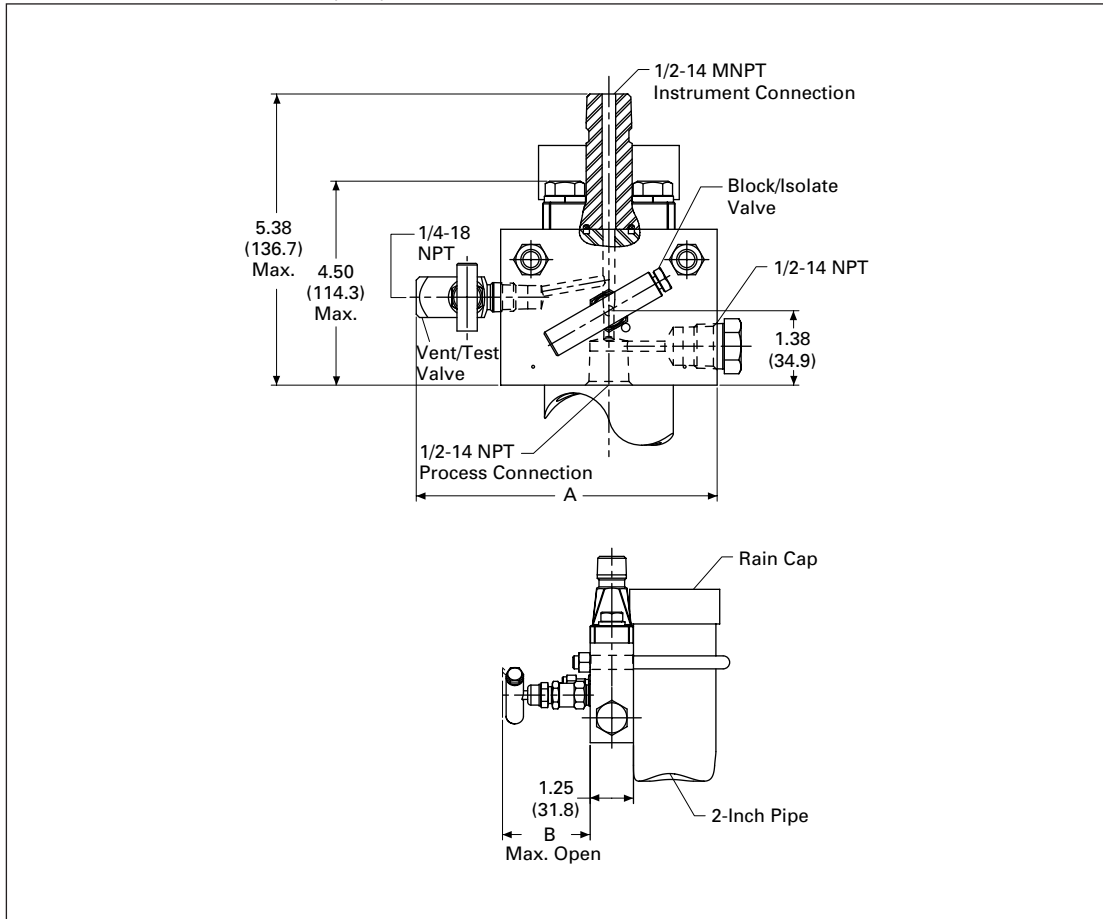

Dimensions in Inches (mm)

Packing	A	B
Teflon	5.62 (142.7)	3.85 (97.8)
GRAFOIL/Low Emissions Graphite	8.20 (208.3)	4.50 (114.3)

Note: Approximate valve weight: 6.0 lb (2.72 kg).
0.187-inch (4.8 mm) diameter orifice.
Cv = .52, full open.

Pressure seal between union connectors and manifold body is Viton® O-ring for Teflon packed valves, GRAFOIL for GRAFOIL packed valves.

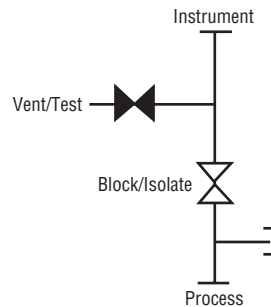

Kerotest KMP1 & KMP2 Static Pressure Manifolds

Specifications

KMP2 Dimensions in Inches (mm)

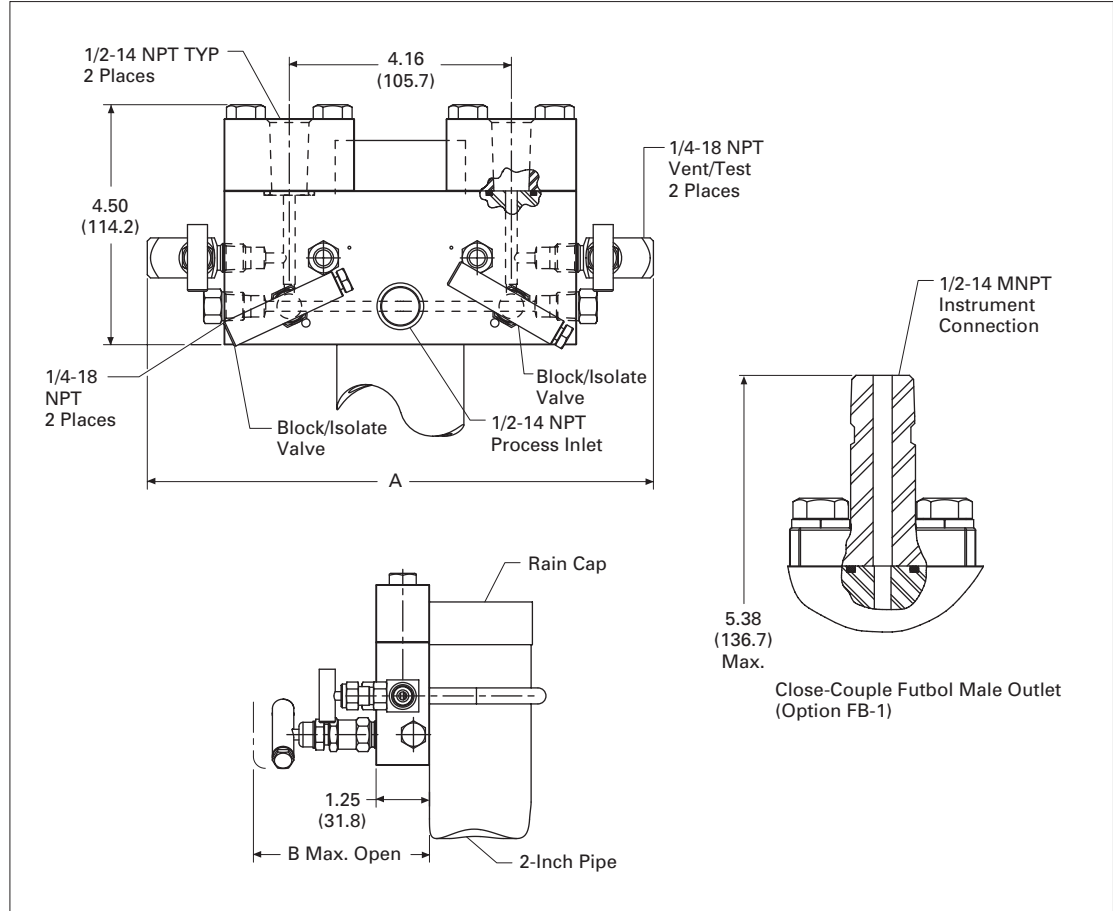

Dimensions in Inches (mm)

Packing	A	B
Teflon	9.81 (249.2)	3.85 (97.8)
GRAFOIL/Low Emissions Graphite	13.98 (355.1)	4.50 (114.3)

Note: Approximate valve weight: 10.0 lb (4.54 kg).
0.187-inch (4.8 mm) diameter orifice.
Cv = .52, full open.

Pressure seal between union connectors and manifold body is Viton O-ring for Teflon packed valves, GRAFOIL for GRAFOIL packed valves.

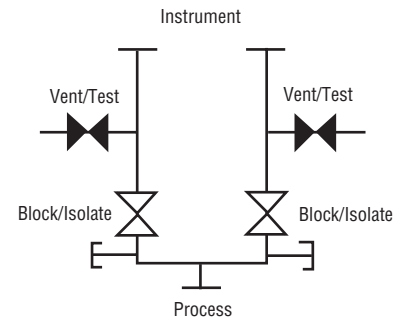

Kerotest KMP1 & KMP2 Static Pressure Manifolds

Standard Materials – KMP1

Valve	Body	Bonnet	Stem/Ball (Block Valve)	Stem (Bleed Valve)	Vent/Test Valve	Bolts
CS ①	A105	A108	A581-303 Stem 17-4 Ball	A581-303	A105 ④	A193-B7
SS	A479-316	A479-316	A276-316 Stem 316 SS Ball	A276-316	A479-316	A193-B7
SG ②	A479-316	A479-316	Monel 400 Stem Monel K500 Ball	Monel R405	A479-316	A193-B7
Monel®	Monel 400	Monel R405	Monel 400 Stem Monel K500 Ball	Monel R405	Monel	A193-B7
SG3 ③	Hastelloy® C276	Hastelloy C276	Hastelloy C276 Stellite	Hastelloy	Hastelloy	A193-B7

Standard Materials – KMP2

Valve	Body	Bonnet	Stem/Ball (Block Valve)	Stem (Bleed Valve)	Vent/Test Valve	Bolts
CS ①	A108	A108	A581-303 Stem 17-4 Ball	A581-303	A105 ④	A193-B7
SS	A479-316	A479-316	A276-316 Stem 316 SS Ball	A276-316	A479-316	A193-B7
SG ②	A479-316	A479-316	Monel 400 Stem Monel K500 Ball	Monel 405	A479-316	A193-B7
SG3 ③	Hastelloy C276	Hastelloy C276	Hastelloy C276 Stellite	Hastelloy	Hastelloy	A193-B7

Pressure and Temperature Ratings

Valve	Packing	Ratings
CS ①, SS and SG ②	Teflon	6000 psig @ 200°F (414 bar @ 93°C) 4000 psig @ 400°F (276 bar @ 204°C)
CS ①	GRAFOIL/Low Emissions Graphite	6000 psig @ 200°F (414 bar @ 93°C) 1500 psig @ 850°F (103 bar @ 454°C)
SS SG ②	GRAFOIL/Low Emissions Graphite	6000 psig @ 200°F (414 bar @ 93°C) 1500 psig @ 1000°F (103 bar @ 538°C)

- ① CS parts are zinc cobalt-plated to prevent corrosion.
- ② SG (Sour Gas) meets the requirements of NACE MR0175-2002.
- ③ SG3 (Sour Gas) meets the requirements of NACE MR0175-2003.
- ④ Teflon packed bleed valve body is 10L18 steel.

Kerotest KMP1 & KMP2 Static Pressure Manifolds

Pressure vs. Temperature

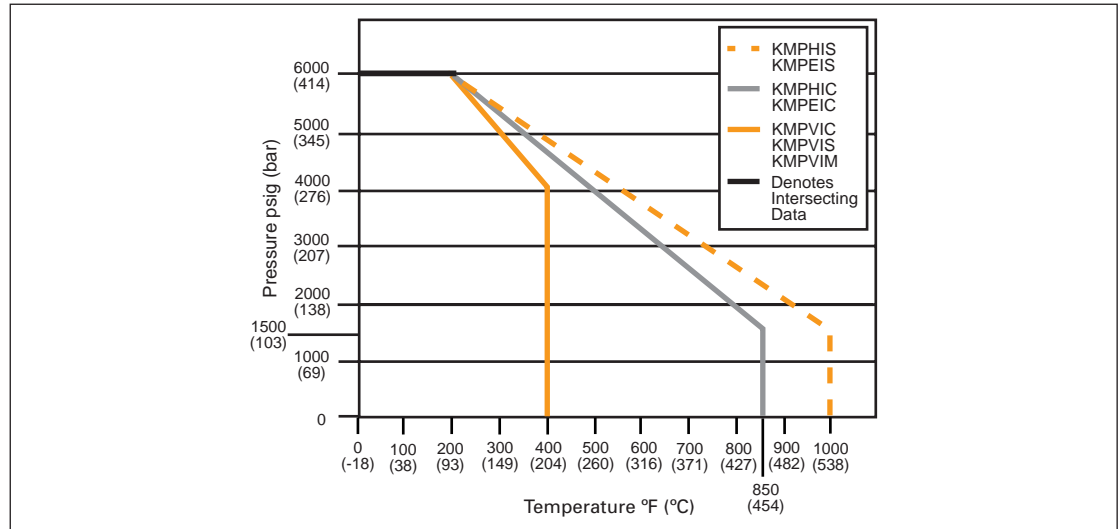

Ordering Information

KMP1	V	I	C	-	44	-	SB
1.	2.	3.	4.		5.		6.
1. Style KMP1 – Pressure Manifold (One Instrument) KMP2 – Pressure Manifold (Two Instruments)	2. Packing V – Teflon H – GRAFOIL E – Low Emissions Graphite	3. Seat I – Integral (Body Material)	4. Body Material C – CS S – 316 SS M – Monel W – 316L SS J – Hastelloy	5. Connection 4 – 1/2-Inch FNPT Process x 1/2-Inch FNPT Instrument 44 – 1/2-Inch FNPT Process x 1/2-Inch MNPT Instrument (KMP1 Only) 4-FB1 – KMP2 with 1 Each 1/2-Inch MNPT Process x 1/2-Inch FNPT Instrument	6. Options ① BC – Conduit Connection Bracket BL – Bonnet Lock Device (Block Valves) FB1 – KMP2 with 1 Each MNPT and FNPT Connectors SB – Steam Block SG – Sour Gas Meets the Requirements of NACE MR0175-2002 (SS Valves Only) SG3 – Sour Gas Meets the Requirements of NACE MR0175-2003		

① Includes U-bolt and nuts for 2-inch pipe mounting.

All product names referenced herein are trademarks of their respective companies.