



FLOOR DRAINS

FIG. 2005 (L-T) FLOOR DRAIN AND ADJ. STRAINER WITH RECTANGULAR GRATE
FIG. 2010 (L-T) FLOOR DRAIN AND ADJ. STRAINER WITH RECTANGULAR GRATE



FUNCTION: Used in shower room, gutters and similar areas where large grate free area is required and limited width is available.

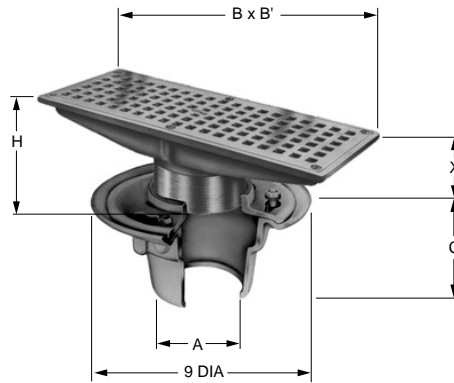

OUTLET VARIATIONS (Specify type of outlet and pipe size in inches.)

Outlet Type	Outlet Designation	Outlet Type/Pipe Size	"C" Body HT. DIM.	ADD
Inside Caulk (2010)	C02, C03, C04	4"	N/C
Speedi-Set SW (2005)	L02, L03, L04	4"	N/C
Speedi-Set XH (2005)	LXH02, LXH03, LXH04	4"	N/C
Threaded(2010)	T02, T03, T04	3"	47.00
No-Hub (2005)	Y02, Y03, Y04	4"	N/C

OPTIONS:

Option	Description	ADD
-ARI	Acid Resistant Inside	102.00
-B	Sediment Bucket	65.00
-BB	Bronze Body, 02-04"	734.00
	05-06"	2,255.00
-BFV	Ball Float Backwater Valve	230.00
-DID*	Drain Installation Device	83.00
-G	Galvanized Body	119.00
-P	Trap Primer Conn	N/C
-U	Vandal Proof Screws	33.00
-V	Flapper Backwater Valve	230.00

FLOOR DRAINS

A OUTLET SIZE	STRAINER SUFFIX	B X B STRAINER SIZE	X MIN MAX	H	DUCO CI PB TOP	DUCO CI †NB TOP	DUCO CI CP TOP	APPROX. WEIGHT LBS.
02, 03, 04"	L	4 1/4 x 08"	1 3/8" 2 3/8"	2 1/4"	598.00	643.00	696.00	17
02, 03, 04"	M	04 x 12"	1 7/8" 2 3/4"	2 1/2"	678.00	776.00	841.00	19
02, 03, 04"	N	05 x 09"	1 3/8" 2 3/8"	2 1/4"	598.00	643.00	696.00	21
02, 03, 04"	P	05 x 13"	2 1/8" 3"	3"	792.00	872.00	945.00	24
02, 03, 04"	R	06 x 10"	1 3/8" 2 3/8"	2 1/4"	792.00	872.00	945.00	26
02, 03, 04"	T	05 x 17"	2 1/4" 3 1/8"	3"	847.00	928.00	1,009.00	29

*Applies to 2005 only.

REGULARLY FURNISHED: Duco Cast Iron Body and Flashing Collar, Adjustable Strainer Head as Indicated by Suffix Letter Selected.

FIG. 2005 (-V) FLOOR DRAIN AND ADJ. STRAINER WITH ANGLE GRATE
FIG. 2010 (-W) FLOOR DRAIN AND ADJ. STRAINER WITH ANGLE GRATE

FUNCTION: Shower room drain set at wall and floor junction. Vertical grate openings prevent drain stoppage should flat surface become covered.

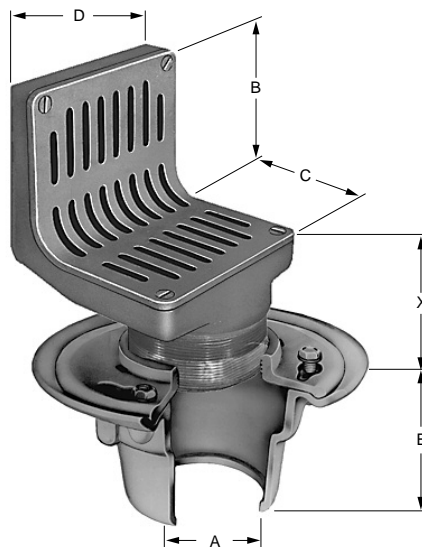

OUTLET VARIATIONS (Specify type of outlet and pipe size in inches.)

Outlet Type	Outlet Designation	Outlet Type/Pipe Size	"E" Body HT. DIM.	ADD
Inside Caulk (2010)	C02, C03, C04	4"	N/C
Speedi-Set SW (2005)	L02, L03, L04	4"	N/C
Speedi-Set XH (2005)	LXH02, LXH03, LXH04	4"	N/C
Threaded(2010)	T02, T03, T04	3"	47.00
No-Hub (2005)	Y02, Y03, Y04	4"	N/C

OPTIONS:

Option	Description	ADD
-ARI	Acid Resistant Inside	102.00
-BB	Bronze Body, 02-04"	734.00
	05-06"	2,255.00
-DID*	Drain Installation Device	83.00
-G	Galvanized Body	119.00
-P	Trap Primer Conn	N/C
-U	Vandal Proof Screws	33.00

*Applies to 2005 only.

A OUTLET SIZE	STRAINER SUFFIX	B	C	D	X MIN MAX	DUCO CI PB TOP	DUCO CI †NB TOP	DUCO CI CP TOP	APPROX. WEIGHT LBS.
02, 03, 04"	V	3 1/2"	3 1/2"	4 1/2"	1 5/8" 2 5/8"	1,098.00	1,190.00	1,300.00	19
02, 03, 04"	W	6 3/4"	6 3/4"	6 1/2"	1 5/8" 2 5/8"	1,373.00	1,490.00	1,624.00	28

REGULARLY FURNISHED: Duco Cast Iron Body and Flashing Collar, Adjustable Strainer Head as Indicated by Suffix Letter Selected.

When ordering, specify drain body and strainer type, size and finish. Ex. 2005Y04 w/A05NB.

