



Commercial Boxed Wall Hydrants

6" STAINLESS STEEL DIAMETER
CORED HOLE BOX TYPE QUARTER
TURN NON-FREEZE WALL
HYDRANT WITH CONCEALED
HOSE CONNECTION



FIG. # 5509QT-R

Cored Hole Hydrant and Stainless Steel Box

FUNCTION:

This round box hydrant is designed to fit into a 6" hole drilled into a concrete wall with a 6" diameter core drill. The stainless steel recessed hydrant box conceals the nozzle and operating mechanism of the 5609QT hydrant making for a clean and simple installation. The stainless steel box comes complete with a vertical hinge avoiding pinched fingers caused by standard horizontal latch type covers. The hinged locking cover opens 180° for clear hydrant access and prevents unauthorized use.

PRODUCT FEATURES:

- Quarter-turn full-flow feature
- 3/4" (19) inlet and hose connection
- Removable "T" handle key
- Non-freeze hydrant with integral vacuum breaker
- Fits 6" dia. cored drill hole
- Flush installation to eliminate catch points
- Frame, cover & housing are made of 16 gauge, type 304 stainless steel
- Locking hinged cover opens 180°
- Simple & easy to install in cored drill concrete wall
- Replacement parts are available in kit HPRK-7

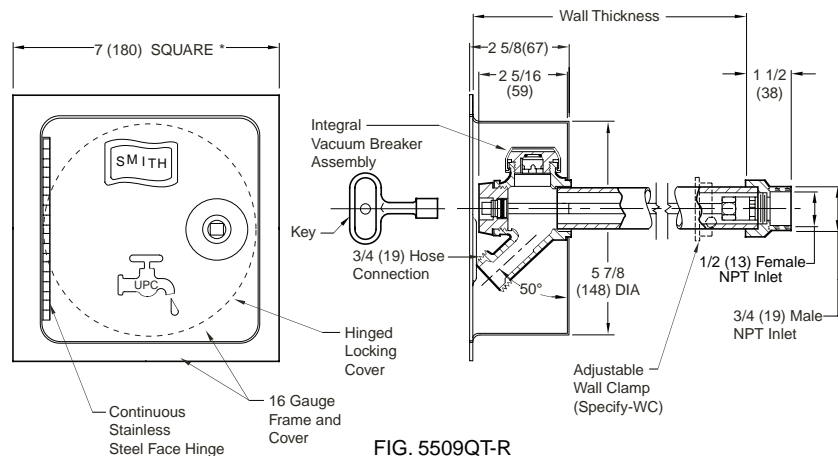

FIG. 5509QT-R

NOTE: Dimensions shown in parentheses are in millimeters.

Regularly Furnished:

Bronze Nickel Plated Quarter Turn Non-Freezing Hydrant with Hose Connection, Integral Vacuum Breaker, "T" Handle Key, and Stainless Steel Box with Full 180° Cover Opening

Variations:

- Adjustable Wall Clamp -WC
- Cylinder Lock -CL
- 1" (25) Hose Connection -HC1
- 1" (25) Male NPT Inlet Connection -IC1
- "Water" On Cover -W