



FLOOR DRAINS

FIG. 2005 (-J) FLOOR DRAIN AND ADJ. STRAINER WITH ROUND SPANNER WRENCH COVER
FIG. 2010 (-J) FLOOR DRAIN AND ADJ. STRAINER WITH ROUND SPANNER WRENCH COVER



FUNCTION: Solid gas tight, vandal proof, threaded cover for areas where intermittent drain use is required.

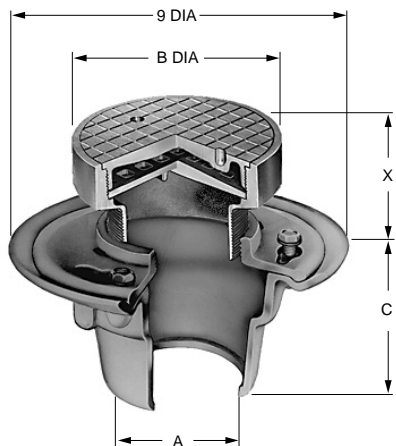

A OUTLET SIZE	B STRAINER SIZE	X		DUCO CI PB TOP	DUCO CI †NB TOP	DUCO CI CP TOP	APPROX. WEIGHT LBS.
		MIN	MAX				
02, 03, 04"	06"	2	3	643.00	688.00	746.00	19

REGULARLY FURNISHED: Duco Cast Iron Body and Flashing Collar, Adjustable Strainer Head as Indicated by Suffix Letter Selected.

OUTLET VARIATIONS (Specify type of outlet and pipe size in inches.)

Outlet Type	Outlet Designation	Outlet Type/Pipe Size	"C" Body HT. DIM.	ADD
Inside Caulk (2010)C02, C03, C04	4"	N/C
Speedi-Set SW (2005)L02, L03, L04	4"	N/C
Speedi-Set XH (2005)LXH02, LXH03, LXH04	4"	N/C
Threaded(2010)T02, T03, T04	3"	47.00
No-Hub (2005)Y02, Y03, Y04	4"	N/C

OPTIONS:

Option	Description	ADD
-ARI	Acid Resistant Inside	102.00
-B	Sediment Bucket	65.00
-BB	Bronze Body, 02-04"	734.00
	05-06"	2,255.00
-BFV	Ball Float Backwater Valve	230.00
-DID*	Drain Installation Device	83.00
-G	Galvanized Body	119.00
-P	Trap Primer Conn	N/C
-SC	Smooth Cover	123.00
-SW	Spanner Wrench	84.00
-V	Flapper Type Backwater Valve	230.00

*Applies to 2005 only.

FIG. 2005 (-K) FLOOR DRAIN AND ADJ. STRAINER WITH SQUARE REINFORCED GRATE
FIG. 2010 (-K) FLOOR DRAIN AND ADJ. STRAINER WITH SQUARE REINFORCED GRATE

FUNCTION: Used in finished floors where some light wheeled traffic is anticipated.

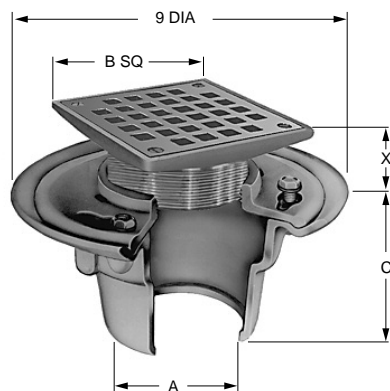

A OUTLET SIZE	B STRAINER SIZE	X		DUCO CI PB TOP	DUCO CI †NB TOP	DUCO CI CP TOP	APPROX. WEIGHT LBS.
		MIN	MAX				
02, 03, 04"	05 x 05"	1 1/4	2 1/4	427.00	457.00	494.00	14
02, 03, 04"	06 x 06"	1 1/4	2 1/4	508.00	536.00	575.00	16
02, 03, 04"	07 x 07"	1 1/4	2 1/4	584.00	611.00	658.00	17
02, 03, 04"	08 x 08"	1 1/2	2 1/2	699.00	754.00	819.00	18

REGULARLY FURNISHED: Duco Cast Iron Body and Flashing Collar, Adjustable Strainer Head as Indicated by Suffix Letter Selected.

OUTLET VARIATIONS (Specify type of outlet and pipe size in inches.)

Outlet Type	Outlet Designation	Outlet Type/Pipe Size	"C" Body HT. DIM.	ADD
Inside Caulk (2010)C02, C03, C04	4"	N/C
Speedi-Set SW (2005)L02, L03, L04	4"	N/C
Speedi-Set XH (2005)LXH02, LXH03, LXH04	4"	N/C
Threaded (2010)T02, T03, T04	3"	47.00
No-Hub (2005)Y02, Y03, Y04	4"	N/C

OPTIONS:

Option	Description	ADD
-ARI	Acid Resistant Inside	102.00
-B	Sediment Bucket	65.00
-BB	Bronze Body, 02-04"	734.00
	05-06"	2,255.00
-BFV	Ball Float Backwater Valve	230.00
-DID*	Drain Installation Device	83.00
-G	Galvanized Body	119.00
-P	Trap Primer Conn	N/C
-U	Vandal Proof Screws	33.00
-V	Flapper Type Backwater Valve	230.00

*Applies to 2005 only.

When ordering, specify drain body and strainer type, size and finish. Ex. 2005Y04 w/A05NB.

