



# SPECIALTIES, STAINLESS AND CARBON STEEL

## FIG. 9110, 9120 ADJUSTABLE "P" TRAP STANDARDS-CAST IRON



**FUNCTION:** For use with all service sinks.

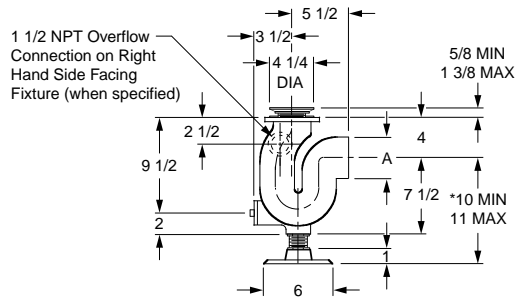

**OPTIONS:**

- N15 1 1/2" Overflow Connection (9120 Only) ..... **ADD 209.00**
- SS For use with Stainless Steel Sink..... **N/C**

FIGURE NO.	PIPE SIZE	FREE AREA SQ IN	CONNECTION	†ARE INSIDE	ARE INSIDE AND OUTSIDE	APPROX. WT. LBS.
9110	02"	2"	Threaded	553.00	725.00	16
9120	03"	2"	Threaded	553.00	725.00	22

**REGULARLY FURNISHED:** Chrome Plated Strainer, Rubber Gasket and Bronze Cleanout Plug. Cast Iron with White Duco Coated Outside and Acid Resistant Coated Inside.

\*Roughing shall be coordinated with sink used.

## FIG. 9114 TO 9128 ADJUSTABLE "P" TRAP STANDARDS-ALL BRONZE

**FUNCTION:** For use with all service sinks.

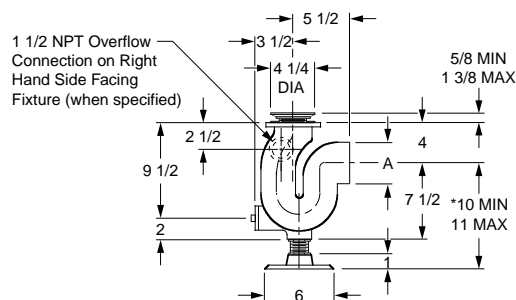

**OPTIONS:**

- N15 1 1/2" Overflow Connection (9124 thru 9128 Only) ..... **ADD POA**
- SS For use with Stainless Steel Sink..... **N/C**

FIGURE NO.	PIPE SIZE	FREE AREA SQ IN	CONNECTION	†ALL BRONZE	APPROX. WT. LBS.
▲9114	02"	2"	Threaded	POA	18
▲9116	02"	2"	Sil-Brazed Outlet	POA	18
9118	02"	2"	Sil-Brazed Grooved	POA	18
9124	03"	2"	Threaded	POA	20
9126	03"	2"	Sil-Brazed Outlet	POA	20
9128	03"	2"	Sil-Brazed Grooved	POA	40

**REGULARLY FURNISHED:** Chrome Plated Strainer, Rubber Gasket and Bronze Cleanout Plug. Bronze Trap as Cast.

\*Roughing shall be coordinated with sink used.

▲Conforms to Military Specification MIL S-2143-B Amendment 1

FOR INFORMATION ON POA ITEMS, PLEASE CONTACT YOUR LOCAL JAY R. SMITH REPRESENTATIVE

