



# BACKWATER VALVES AND TRAPS

## FIG. 7150 IN-LINE MANUAL SHUT-OFF VALVE



**FUNCTION:** Functions as a drainage control valve; flapper type backwater valve provides temporary protection against sewage backflow surges. Manually closed "spade" type gate valve provides additional complete "closure" protection during emergency conditions, when building is completely shut down or during extended periods of backflow conditions.

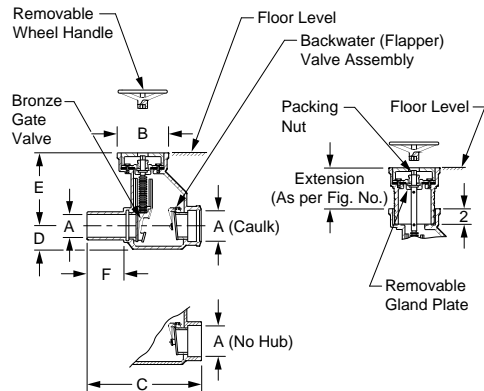

### INLET VARIATIONS

<b>Inlet Type</b>	<b>ADD</b>
Caulk.....	N/C
No-Hub.....	N/C
<b>OPTIONS:</b>	<b>DEDUCT</b>
-LW Less Wheel Handle.....	43.00
-SW Sized for Service Weight.....	N/C

FIGURE NO.	EXTENSION	A OUTLET SIZE	B DIA.	C	D	E	F	†DUCO CI BRZ VALVE	GALV CI BRZ VALVE	APPROX. WEIGHT LBS
7150	-	04"	8"	18"	3 3/4"	12"	5"	3,056.00	3,871.00	110
	-	06"	10 1/2"	20"	4 1/2"	14 1/2"	5"	4,502.00	5,317.00	140
7151	12"	04"	8"	18"	3 3/4"	12"	5"	4,316.00	5,131.00	110
7152	24"	04"	8"	18"	3 3/4"	12"	5"	5,574.00	6,389.00	130
7153	9 1/2"	06"	10 1/2"	20"	4 1/2"	14 1/2"	5"	5,760.00	6,575.00	140
7154	21 1/2"	06"	10 1/2"	20"	4 1/2"	14 1/2"	5"	7,019.00	7,834.00	160
7155	Adaptor	04"	8"	18"	3 3/4"	12"	5"	3,968.00	4,783.00	110
	Adaptor	06"	10 1/2"	20"	4 1/2"	14 1/2"	5"	5,592.00	6,407.00	115

**REGULARLY FURNISHED:** Duco Cast Iron Body and Cover with Removable Wheel Handle. Bronze Gate and Bronze Flapper Valve. Cast Iron Extensions as Indicated by Figure Number Selected.

## FIG. 7220, 7221 DEEP SEAL "P" TRAPS W/FEMALE THREADED INLET AND OUTLET (7220) OR MALE THREADED INLET AND FEMALE THREADED OUTLET (7221)

**FUNCTION:** Provides the protection of an independent "deep seal" cast iron trap for use in conjunction with bottom outlet drains. Can be provided with bottom cleanout plug, trap primer connection or low flushing tapping.

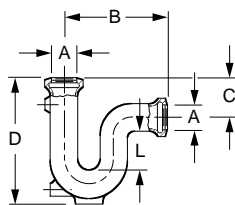

Fig. 7220

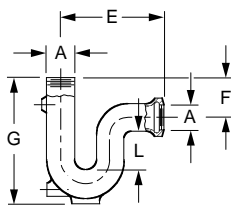

Fig. 7221

<b>OPTIONS:</b>	<b>ADD</b>
-BP Bronze Cleanout Plug.....	124.00
-FC Flushing Connection.....	90.00
-P Trap Primer Conn.....	90.00

A OUTLET SIZE	B	C	D	E	F	G	L SEAL	†DUCO CI	GALV CI	ARC CI INSIDE	ALL BRONZE (-BB)	APPROX. WEIGHT LBS
02"	6 1/4"	2 3/4"	10"	6 1/4"	2 3/4"	10"	4"	266.00	341.00	378.00	POA	10
03"	8"	3"	13"	8"	3"	13"	5"	408.00	587.00	617.00	POA	20
04"	9 3/4"	4 1/4"	15 1/2"	9 3/4"	6"	17 1/2"	5"	613.00	895.00	909.00	POA	33

**REGULARLY FURNISHED:** Duco Cast Iron Trap.

