

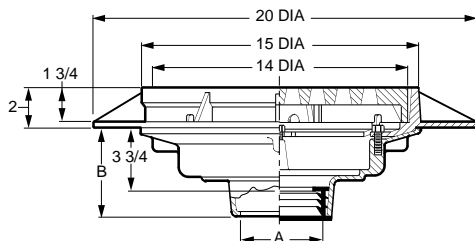

FLOOR DRAINS

FIG. 2624 FLOOR DRAIN WITH HEAVY DUTY WIDE FLANGE FLASHING COLLAR

FUNCTION: Used in parking decks with precast construction where core drilling or boxing out for drain is desired for cost effective installation. The wide reinforced flange provides maximum support of drain.



A OUTLET SIZE	TOP SIZE	FREE AREA SQ IN	†DUCO CI	DUCO CI PB TOP	DUCO CI NB TOP	APPROX. WEIGHT LBS
02, 03, 04"	15"	45	1,537.00	2,196.00	2,336.00	44
05, 06"	15"	45	1,537.00	2,196.00	2,336.00	44
08, 10"	16"	45	1,722.00	2,381.00	2,521.00	48

REGULARLY FURNISHED: Duco Cast Iron Body, Heavy Duty Wide Flange Flashing Collar with Heavy Duty Tractor Gate.

OUTLET VARIATIONS (Specify type of outlet and pipe size in inches.)

Outlet Type	Outlet Designation Outlet Type/Pipe Size	"B" Body HT. DIM.	ADD
Inside Caulk	C02, C03, C04, C05 C06	.5	N/C
	C08, C10	.6	N/C
Speedi-Set SW	L02, L03, L04	.5	N/C
Speedi-Set XH	LXH02, LXH03, LXH04	.5	N/C
Threaded	T02, T03, T04, T05, T06	3 3/4	47.00
	T08, T10	.5	47.00
No-Hub	Y02, Y03, Y04, Y05, Y06	.5	N/C
	Y08, Y10	.6	N/C
Side Outlet			See Fig. 2648S

OPTIONS:

OPTION	DESCRIPTION	ADD
-C	Underdeck Clamp	146.00
-DBSCI	Dome Bottom Strainer, CI	58.00
-FBSCI	Flat Bottom Strainer, CI	36.00
-G	Galvanized CI	666.00
-M	Ductile Iron Gate	400.00
-R	Sump Receiver	164.00
-S	Square Top, CI	286.00
-SNB	Square Top, add to CI	1,198.00
-SPB	Square Top, add to CI	1,036.00
-U	Vandal Proof Screws	89.00

FIG. 2630 LIGHT DUTY HOPPER DRAIN WITH SEDIMENT BUCKET AND GRATE

FUNCTION: Hopper type drain for use in areas not subject to traffic.

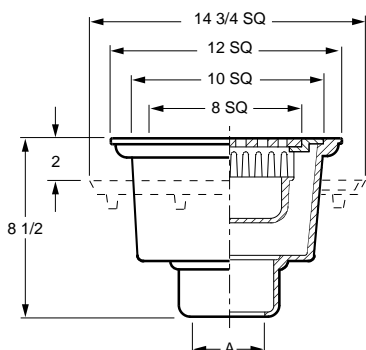

A OUTLET SIZE	TOP SIZE	FREE AREA SQ IN	†DUCO CI	DUCO CI PB TOP	DUCO CI NB TOP	APPROX. WEIGHT LBS
02, 03, 04"	12" SQ	23	748.00	1,338.00	1,450.00	30

REGULARLY FURNISHED: Duco Cast Iron Body with Sediment Bucket and Grate.

OUTLET VARIATIONS (Specify type of outlet and pipe size in inches.)

Outlet Type	Outlet Designation Outlet Type/Pipe Size	ADD
Inside Caulk	C02, C03, C04	N/C
No-Hub	Y02, Y03, Y04	See Fig. 2646Y
Threaded	T02, T03, T04	47.00

OPTIONS:

OPTION	DESCRIPTION	ADD
-BT	Bell Trap Assembly	107.00
-F	Flange, Cast Iron	223.00
-FC	Flange w/Flashing Clamp	353.00
-G	Galvanized CI	443.00
-M	Ductile Iron Gate	207.00
-MBG	Ductile Iron Bucket & Grate	322.00
-P	Trap Primer Connection	117.00
-U	Vandal Proof Screws	89.00
-12	Half Grate	74.00
-13	Three Quarter Grate	74.00

