

**401**  
6/05

# Suspension Systems for Acoustical Lay-in Ceilings

THIS DOCUMENT HAS BEEN APPROVED BY THE BUILDING DEPARTMENT

for official use only

This document provides the various standards for the installation of suspension systems for acoustical lay-in ceilings. Incorporation of this document will provide a more uniform standard for installation and inspection. This document is designed to accomplish the intent of the International Building Code (IBC) with regard to the requirements for seismic design category D for suspended ceilings and related items. Unless supported by engineering or approved by local building department, the suspension system shall be installed per the requirements for Seismic Design Category (SDC) D, E and F per the IBC. Manufacturers' recommendations should be followed

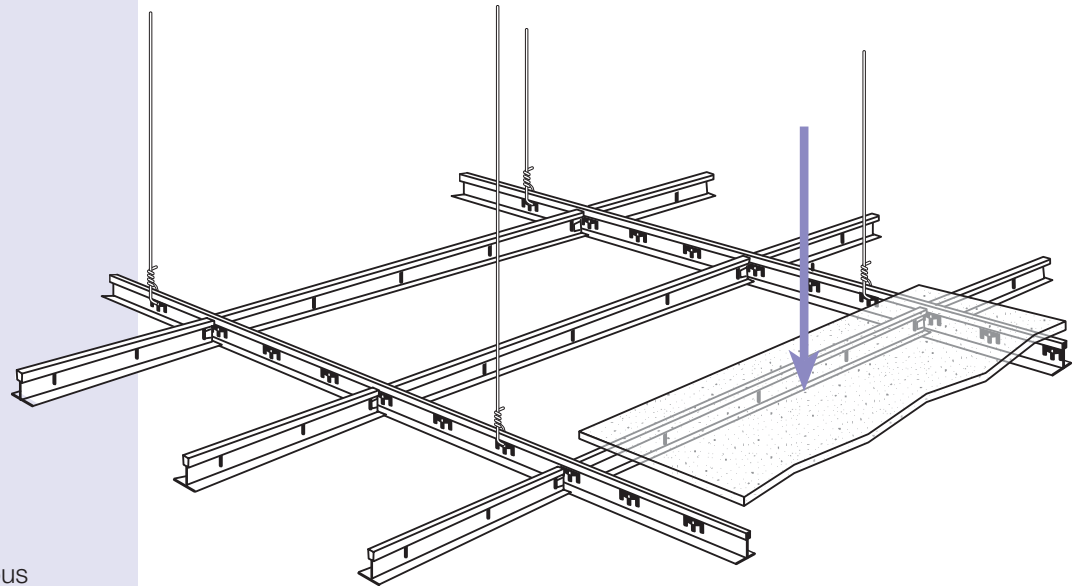

## General Recommendations

- Referenced sources per hierarchy: 2003 IBC (International Building Code), American Society of Testing Materials (ASTM C 635, ASTM C 636), American Society of Civil Engineers (ASCE 7-02) and Ceilings and Interior Systems Construction Association (CISCA).
- Partitions that are tied to the ceiling and all partitions greater than 6 feet in height shall be laterally braced to the structure. Bracing shall be independent of the ceiling splay bracing system. *Source IBC section 1621.1.2*

For further information on bracing of non-load bearing partitions refer to NWCB technical document #201.

- All main beams are to be Heavy Duty (HD). *Source ASCE 7-02 item 9.6.2.6.2.a*
- All cross tees shall be capable of carrying the design load without exceeding deflection equal to 1/360 of its span. *Source CISCA zones 3-4*

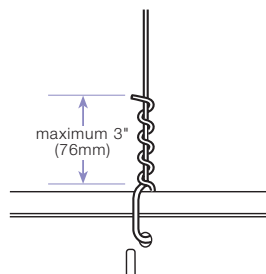

figure 1

- These recommendations are intended for suspended ceilings including grid, panel or tile, light fixtures and air terminals weighing no more the 4 lbs. per square foot. *Source ASCE 7-02 item 9.6.2.6.1*
- All wire ties are to be three tight turns around itself within three inches. Twelve gage Hanger wire spaced 4 foot on center (*figure 1*). *Source ASTM C 636 item 2.3.4*
- Changes in ceiling planes will require positive bracing.

*Source ASCE 7-02 Section 9.6.2.6.2.2. item f.*

figure 2  
Lateral force Bracing

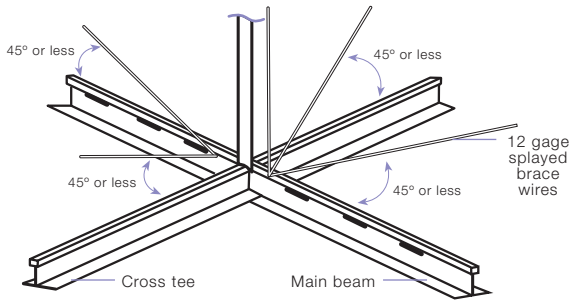

figure 3  
Maximum Recommended Lengths for Vertical Struts

EMT CONDUIT	
1/2" EMT conduit	up to 6' 0"
3/4" EMT conduit	up to 8' 6"
1" EMT conduit	up to 10' 0"
1 METAL STUD	
1 5/8" metal stud (25 gage)	up to 6' 2"
2 1/2" metal stud (25 gage)	up to 10' 6"

Source Portland Building Department

Note: Plenum areas greater than 11' 0" will require engineering calculations.

## Lateral Force Bracing (figures 2 and 3)

- Ceilings constructed of lath and plaster or gypsum board, screw or nail attached to suspended members that support a ceiling on one level extending from wall to wall shall be exempt from the lateral force bracing requirements. *Source CISCA zones 3-4*
- Lateral force bracing is the use of vertical struts (compression posts) and splay wires (see figure 2).
- Lateral force bracing is required for ceilings over 1,000 square feet and not required for ceilings less than 1,000 square feet provided they are surrounded by four walls and braced to structure. *Source ASCE 7-02 section 9.6.2.6.2.2 item c*
- Lateral Force Bracing shall be 12 feet on center (maximum) and begin no farther than 6 feet from walls. *Source CISCA Seismic zones 3-4*
- Splay wires are to be four 12 gage wires attached to the main beam. Wires are arrayed 90° from each other and at an angle not exceeding 45° from the plane of the ceiling. *Source CISCA Seismic zones 3-4*
- Splay wires are to be within 2 inches of the connection of the vertical strut to suspended ceiling. *Source CISCA Seismic zones 3-4*
- Rigid bracing may be used in lieu of splay wires. *Source ASCE section 9.6.2.6.2.2*
- Ceilings with plenums less than 12 inches to structure are not required to have lateral force bracing. *Source Portland Building Department*
- Vertical struts must be positively attached to the suspension systems and the structure above. *Source CISCA 3-4*
- The vertical strut may be EMT conduit, metal studs or a proprietary compression post (see figure 3).

## Wall Moldings (figure 4)

- Wall moldings (perimeter closure angles) are required to have a horizontal flange 2 inches wide, unless alternate methods are approved prior to installation by the local building department and the designer of record. One end of the ceiling grid shall be attached to the wall molding, the other end shall have a 3/4 inch clearance from the wall and free to slide. *Source ASCE 7-02 section 9.6.2.6.2.2 item b*
- The grid shall be attached at two adjacent walls (pop rivets or approved method). *Source CISCA Seismic zones 3-4*
- There shall be a minimum 3/4 inch clearance from the end of the grid system at un-attached walls. *Source ASCE 7-02 section 9.6.2.6.2.2 item b*

## Spreader Bars (figure 4)

- Spreader (spacer) bars or other means approved by local building department shall be used to prevent the ends of the main beams at perimeter walls from spreading open during a seismic event. Perimeter wires shall not be in lieu of spreader bars. *Source CISCA Seismic zones 3-4*
- Wire tying is an acceptable alternative to spreader bars.
- Spreader bars are not required if a 90 degree intersecting cross or main is within 8 inches of the perimeter wall.

## Hanger (Suspension) Wires (figures 5a and 5b)

- Hanger and perimeter wires must be plumb within 1 in 6 unless (figure 5a) counter sloping wires are provided (figure 5b). *Source ASTM C 636 section 2.1.4*
- Hanger wires shall be 12 gage and spaced 4 feet on center or 10 gage spaced 5 feet on center. *Source ASTM C 636*
- Any connection device at the supporting construction shall be capable of carrying not less than 100 pounds. *Source CISCA zones 3-4*

figure 4  
Wall Molding Requirements

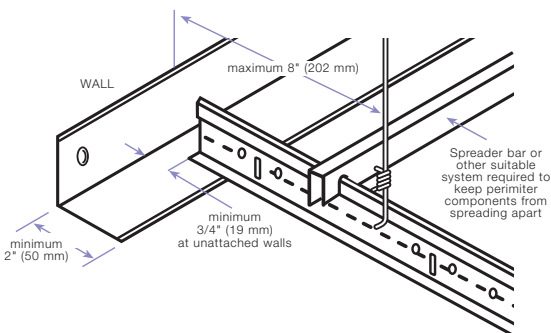

- For essential facilities, hanger wire connections must be capable of carrying 200 pounds and bracing (splay) wires shall be capable of carrying 440 pounds, shot-in anchors in concrete are not permitted for bracing wires. *Source Department of State Architects (DSA) IR M-3*
- Bracing wires shall be attached to the grid and to the structure in such a manner that they can support a design load of not less than 200 pounds or the actual design load, with a safety factor of 2, whichever is greater (figure 6b). *Source CISCA zones 3-4*
- Powder driven fasteners must be approved for the appropriate loading. *Source ASCE 7-02 section 9.6.1.6.5*
- Terminal ends of each main beam and cross tee must be supported within 8 inches of each wall with a perimeter wire (see figure 4 & 5 b). *Source CISCA zones 3-4*

## Electrical fixtures

- Light fixtures weighing less than 10 pounds shall have one 12 gage hanger wire connected from the fixture to the structure above. This wire may be slack. *Source CISCA Seismic zones 3-4*
- Light fixtures weighing more than 10 pounds and less than 56 lbs. shall have two 12 gage wires attached at opposing corners of the light fixture to the structure above. These wires may be slack. *Source CISCA Seismic zones 3-4.*
- Light Fixtures weighing more than 56 lbs. shall be supported by directly from the structure above. These wires must be taut. *Source CISCA Seismic zones 3-4*
- Pendant mounted fixtures shall be directly supported from the structure above using a 9 gage wire or an approved alternate support without using the ceiling suspension system for direct support. *Source CISCA Seismic zones 3-4*
- Tandem fixtures may utilize common wires.

## Mechanical Services

- Terminals or services weighing 20 lbs. but not more than 56 lbs. must have two 12 gage wires connecting them to the ceiling system hangers or the structure above. These wires may be slack. *Source CISCA Seismic zones 3-4*
- Terminals or services weighing more than 56 lbs. must be independently supported directly from the structure above. These wires must be taut. *Source CISCA Seismic zones 3-4*

## Seismic Separation Joints (figure 7)

For ceiling areas exceeding 2500 square feet, a seismic separation joint or full height wall partition that breaks the ceiling shall be provided unless analyses are performed of the ceilings bracing system, closure angles and penetrations to provide sufficient clearance. *Source ASCE 7-02 item 9.6.2.6.2.2 d*

The layout and location of the seismic separation joint shall be per the designer of record and noted on the plans. If a seismic separation joint is required by the designer, the designer may use the generic joint detailed in this document or a proprietary joint. The amount of free movement (gap design) shall be per the designer of record.

## Special Inspections

Special inspections may be required by the jurisdiction or municipality. Contact the local building department.

## Sprinklers

For ceilings without rigid bracing, sprinkler head penetrations shall have a 2 inch oversize ring, sleeve or adapter through the ceiling tile to allow free movement of at least 1 inch in all horizontal directions. Flexible head design that can accommodate 1 inch free movement shall be permitted as an alternate. *Source ASCE 7-02 9.6.2.6.2.2.item e*

figure 5a

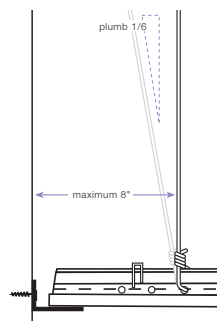

figure 5b • Countersloping

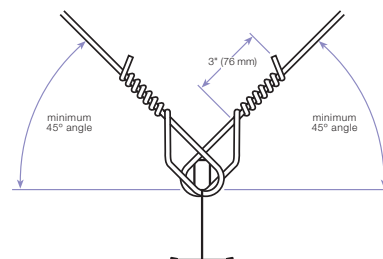

figure 6a

### Vertical hanger wire attachment

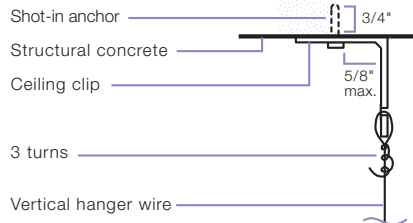

figure 6b

### Splayed seismic bracing wire attachment

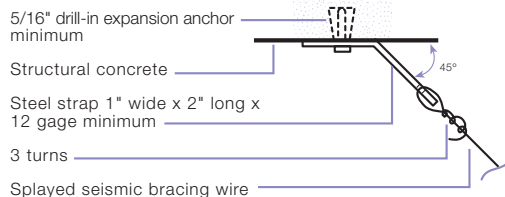
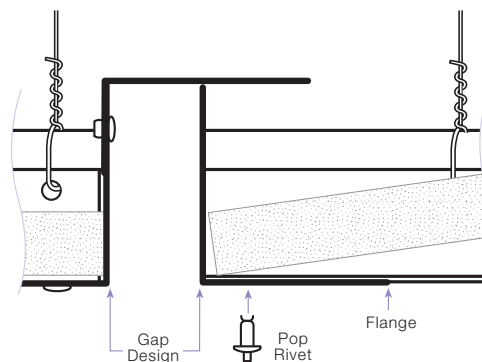

figure 7



## GLOSSARY FOR THIS DOCUMENT (regional terminology may vary)

### CLOSURE ANGLES

Wall molding that surrounds the perimeter of the suspension system and ceiling tiles.

### CROSS TEES

The cross member that interlock with the main beams, also known as cross runners or cross T-bars.

### DIFFUSER

A circular or rectangular metal grill used for the passage of air from a ducted system.

### ESSENTIAL SERVICE BUILDINGS

Any buildings designed to be used by public agencies as a fire station, police station, emergency operations center, State Patrol office, sheriff's office, or emergency communication dispatch center.

### GRID

The main beams and cross tees of the suspension system.

### HANGER WIRE

10 or 12 gage soft annealed wire used as primary support for the grid system. Also called suspension wires.

### LATERAL FORCE BRACING

The bracing method used to prevent ceiling uplift or restrict lateral movement during a seismic event. Lateral force bracing consists of vertical struts and splay wires.

### MAIN BEAM

The primary suspension member supported by hanger wires, also known as the main runner, carrying tee, carrying runner or mains.

### MOLDING

A light gauge metal angel or channel fastened to the wall or partition to support the perimeter of an acoustical tile or ceiling.

### PERIMETER WIRES

Hanger wires placed within eight inches of the surrounding walls.

### PLENUM

The space above a suspended ceiling.

### SLACK WIRE

A 12 gage wire that is not tight or taut.

### SPREADER or SPACER BAR

A bar with notches to prevent the suspension system from separating, also called a stabilizer bar.

### SPLAY WIRES

Wires installed at an angle rather than perpendicular to the grid.

### VERTICAL STRUTS

The rigid vertical member used in lateral force bracing of the suspension system. Also known as compression posts, seismic pods, seismic struts. Common materials are electrical conduit (EMT), metal studs or proprietary products.



1032-A NE 65th St.  
Seattle, WA 98115  
Phone (206) 524-4243  
Fax (206) 524-4136  
Toll Free (800) 524-4215  
info@nwcb.org  
www.nwcb.org

#### NWCB - Oregon

Phone: (503) 295-0333  
Fax: (503) 295-2733

#### B.C. Wall and Ceiling Association

Phone: (604) 597-7180  
Fax: (604) 597-7208

#### Alberta Wall and Ceiling Bureau

Phone: (403) 250-7045  
Fax: (403) 291-9515

The NWCB has been serving the construction industry for over forty years. It is recognized as a technical authority, educational body and spokesperson for the wall and ceiling industry. It provides services to architects and the construction community on all matters relating to the diversified wall and ceiling industry.

As the industry's development and coordination organization, the NWCB saw the need to establish a document to provide clarification and the intent of NEHRP (National Earthquake Hazards Reduction Program) an agency of FEMA (Federal Emergency Management Agency). It is meant to serve as a set of recommendations and is not intended for any specific construction project. The NWCB makes no express or implied warranty or guarantee.