



The new degree of comfort.™

C^oNDENSING TANKLESS



The Next Level of Tankless: Prestige™ high efficiency condensing tankless gas water heaters

- 94% energy efficient and exceeds ENERGY STAR® requirements
- Indoor direct vent with PVC piping and outdoor models
- RTGH-95 series – 11,000-199,900 Btu/h for 3 bathroom homes
- RTGH-84 series – 11,000-157,000 Btu/h for 2-3 bathroom homes

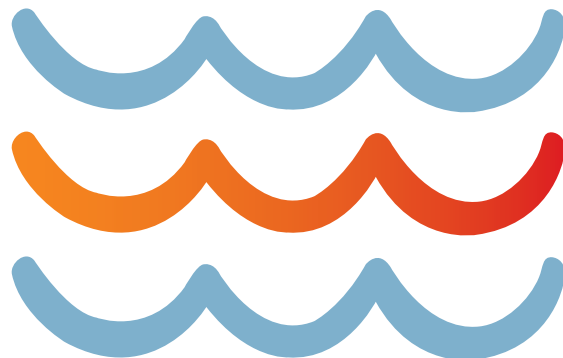

Rheem Prestige™ Condensing Tankless offers an unbeatable combination of ultra-high efficiency and continuous hot water

Rheem uses sophisticated condensing technology to create the most efficient whole home tankless water heating solution available from Rheem. The popularity of luxury bathrooms and oversize tubs is growing, and so is the demand for large volumes of low-cost hot water. Rheem's Prestige™ tankless design offers unparalleled convenience and low-cost operation.



94%
EFFICIENT



Efficiency

- 94% energy efficient with stainless steel condensing heat exchanger
- Intelligent electronic controls designed to increase energy efficiency and safety
- Third-party efficiency listed by AHRI

Performance

- Industry First! 0.26 GPM minimum flow rate, 0.40 GPM minimum activation flow rate
- RTGH-95 for 3 bathroom homes* – 9.5 gal./min. at 35°F rise max., 8.4 gal./min. at 45°F rise SCAQMD 1146.2 compliant
- RTGH-84 for 2-3 bathroom homes* – 8.4 gal./min. at 35°F rise max., 6.6 gal./min. at 45°F rise SCAQMD 1146.2 compliant

Compact Size

- Compact space saving design – about the size of a medicine cabinet

Self-Diagnostic System

- Self-diagnostic system for easy installation and service
- Digital display shows temperature setting and maintenance codes

High Altitude Compliant

- High-altitude capability – up to 9,840 ft. elevation above sea level

* Based on simultaneous showers using 2.5 gallons per minute. Flow rates vary depending on temperature of cold water supply.

Technology

- Two-pipe direct vent system designed for PVC pipe, see instructions for details
- Hot start programming helps minimize fluctuation in water temperature, referred to as the “cold water sandwich” effect, during periods of frequent on/off operation
- Built-in electric blower
- Exclusive! Guardian overheat film wrap (OFW)
- EZ-Link cable available for higher demand applications to connect two tankless units to operate as one
- Manifold up to six units with an optional MIC-6 manifold control board
- Manifold up to 20 units with the optional MIC-185 plus the MICS-180 manifold control assembly



Plus...

- Up to 38 ft. of 3" PVC Pipe or 5 ft. of 2" PVC Pipe, see instructions for details
- Digital remote control and 10 ft. of thermostat wire included
- Supplied with a 120 volt power cord (indoor models only)
- Freeze protection to -30°F
- EZ- Spec™ Sizing Software – advanced online tool that takes the guess work out of sizing tankless applications – available at www.rheem.com/tankless

Warranty

- 12-Year on heat exchanger, 5-year on parts and 1-year on labor

See Residential Warranty Certificate for complete information

Commercial Applications

The Prestige Condensing Tankless Series can be upgraded for high-volume commercial use

- Temperature range is 85°F to 185°F

RTGH-95 Upgrade Kits

RTG20240A for RTGH-95DVLN
RTG20240B for RTGH-95DVLP
RTG20240C for RTGH-95XLN
RTG20240D for RTGH-95XLP

RTGH-84 Upgrade Kits

RTG20241A for RTGH-84DVLN
RTG20241B for RTGH-84DVLP
RTG20241C for RTGH-84XLN
RTG20241D for RTGH-84XLP

Note: These upgrade kits are not compatible with previous models. See the 2012 Tankless Parts Catalog for a complete listing.



Superior Construction and Reliability

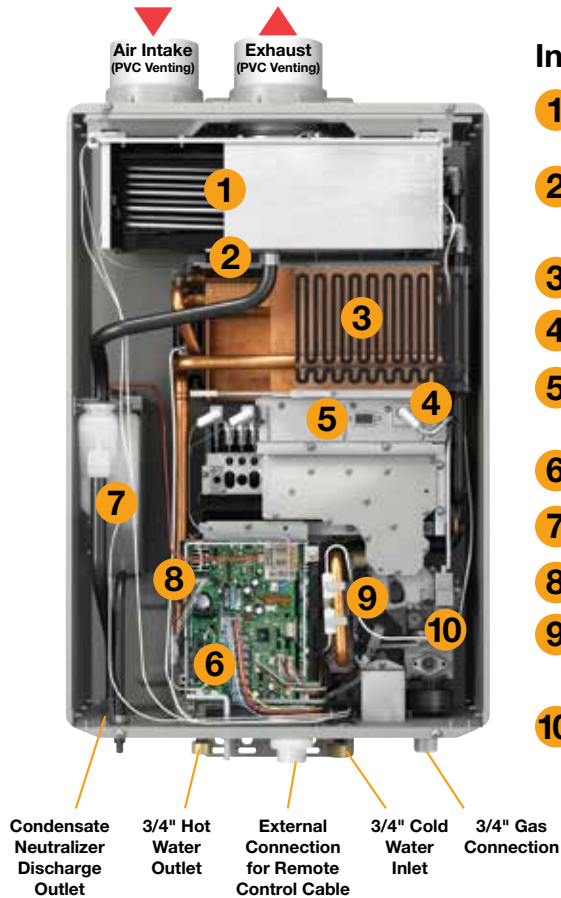

Indoor Direct Vent

- 1 Stainless Steel Secondary Heat Exchanger
- 2 All-Copper Primary Heat Exchanger
- 3 Over Heat Film Wrap
- 4 Electronic Spark Ignition
- 5 199,900 Btu/h Modulating Burner
- 6 Electronic Control Board
- 7 Condensate Reservoir
- 8 Variable Speed Fan
- 9 Water Flow Control System
- 10 Modulating Gas Valve

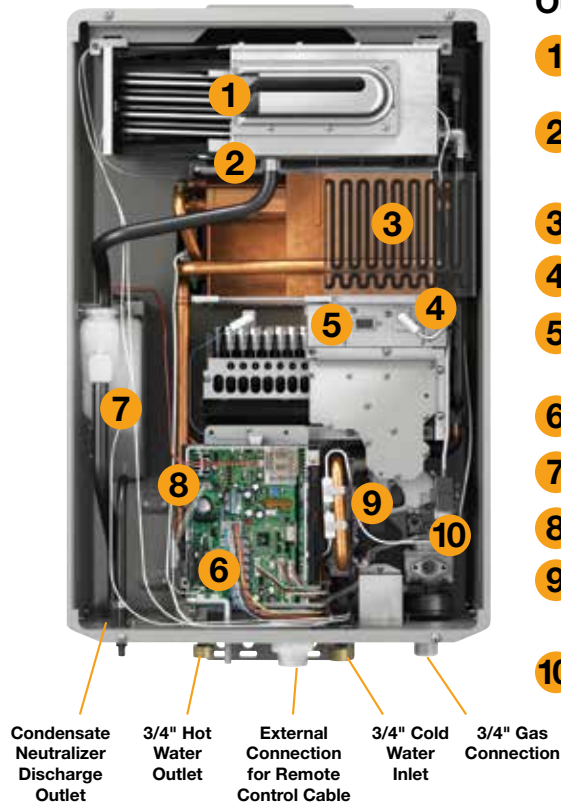

Outdoor

- 1 Stainless Steel Secondary Heat Exchanger
- 2 All-Copper Primary Heat Exchanger
- 3 Over Heat Film Wrap
- 4 Electronic Spark Ignition
- 5 199,900 Btu/h Modulating Burner
- 6 Electronic Control Board
- 7 Condensate Reservoir
- 8 Variable Speed Fan
- 9 Water Flow Control System
- 10 Modulating Gas Valve

Venting Options and Installations

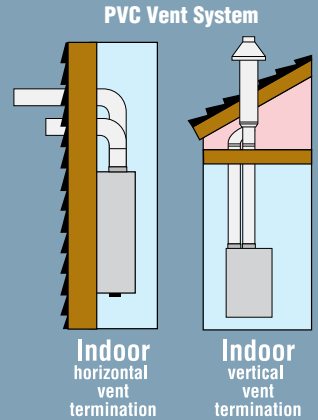

All indoor tankless units must be vented vertically or horizontally to the outdoors using manufacturer approved venting material. See the installation instructions for each specific model. (ULCS636 Pipe must be used for Canada.)

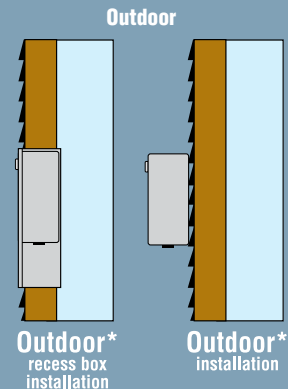

*Outdoor units do not require venting materials.

Venting details, including clearances and diagrams can be found in the "Use & Care Manual" of Rheem indoor tankless water heaters.





The new degree of comfort™



Commercial Gas
Prestige Tankless Water Heaters

Rheem Prestige RTGH-95 Specifications for 3 Bathroom Homes

DESCRIPTION			FEATURES						ROUGHING IN DIMENSIONS (SHOWN IN INCHES)						ENERGY INFO.		
MODEL NUMBER	GAS INPUT BTU/H	TYPE	TEMP. RANGE	MIN. FLOW/ACTIVATION GPM	GPM @ 77° RISE MAX.	GPM @ 45° RISE MAX.	MAX. GPM	CONNECTION		HEIGHT	WIDTH	DEPTH	VENT DIAM.	SHIP. WEIGHT (LBS.)	ENERGY FACTOR	% OF THERM. EFFICIENCY	D.O.E. ANN. OP. COST NAT/LP
								WATER	GAS								
RTGH-95DVLN	11,000-199,900	Indoor Direct Vent	85° to 140° F	0.26/0.40	4.9	8.4	9.5	3/4	3/4	27-1/2	18-1/2	9-3/4	2" or 3" PVC 2-Pipe	82	.94	94%	\$194/326
RTGH-95XLN	11,000-199,900	Outdoor	85° to 140° F	0.26/0.40	4.9	8.4	9.5	3/4	3/4	27-1/2	18-1/2	9-3/4	N/A	82	.94	94%	\$194/326

Rheem Prestige RTGH-84 Specifications for 2-3 Bathroom Homes

DESCRIPTION			FEATURES						ROUGHING IN DIMENSIONS (SHOWN IN INCHES)						ENERGY INFO.		
MODEL NUMBER	GAS INPUT BTU/H	TYPE	TEMP. RANGE	MIN. FLOW/ACTIVATION GPM	GPM @ 77° RISE MAX.	GPM @ 45° RISE MAX.	MAX. GPM	CONNECTION		HEIGHT	WIDTH	DEPTH	VENT DIAM.	SHIP. WEIGHT (LBS.)	ENERGY FACTOR	% OF THERM. EFFICIENCY	D.O.E. ANN. OP. COST NAT/LP
								WATER	GAS								
RTGH-84DVLN	11,000-157,000	Indoor Direct Vent	85° to 140° F	0.26/0.40	3.9	6.6	8.4	3/4	3/4	27-1/2	18-1/2	9-3/4	2" or 3" PVC 2-Pipe	82	.94	94%	\$194/326
RTGH-84XLN	11,000-157,000	Outdoor	85° to 140° F	0.26/0.40	3.9	6.6	8.4	3/4	3/4	27-1/2	18-1/2	9-3/4	N/A	82	.93	94%	\$198/333

Energy Factor and Average Annual Operating Costs based on D.O.E. (Department of Energy) test procedures. D.O.E. national average fuel rate natural gas \$1.218/therm; LP \$1.87/gallon.

All models are available in Natural Gas and Propane (LP). For Propane replace the N with P when ordering.

- SCAQMD 1146.2 compliant.
- Factory set maximum temperature is 120° F. See Use and Care Manual for setting.
- Consult factory for information on sizing the application.
- Add a "C" to the model number when ordering Canadian models. Outdoor models are only for seasonal use in Canada. Please contact Rheem Canada Ltd for details.

Vent Termination Kits are required for Direct Vent models. Contact your distributor for details.

Proper gas pressure must be ensured to supply tankless gas water heaters – up to 199,900 Btu/h for RTGH-95 models, up to 157,000 Btu/h for RTGH-84 models. (Consult your gas supplier)

Model Number	Temperature Rise (° F)									
	35°	45°	50°	60°	70°	77°	80°	90°	100°	
RTGH-95 Water Flow (GPM)	9.5	8.4	7.6	6.3	5.4	4.9	4.7	4.2	3.8	
RTGH-84 Water Flow (GPM)	8.4	6.6	6.0	5.0	4.3	3.9	3.7	3.3	3.0	

Above estimates are for sizing purposes only.

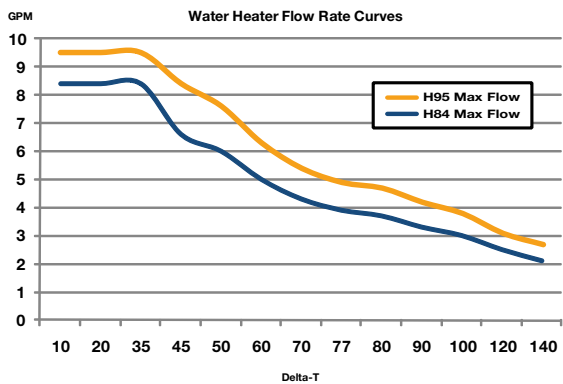

Maximum Vent Length (intake/outlet):

Number of 90° Elbows	Maximum Length of 2" Straight Pipe	Maximum Length of 3" Straight Pipe
0 or 1	5.0 ft. (1.5 m)	38.0 ft. (11.6 m)
2	3.5 ft. (1.0 m)	36.5 ft. (11.1 m)
3	2.0 ft. (0.6 m)	35.0 ft. (10.6 m)
4	Not Available	33.5 ft. (10.2 m)
5	Not Available	32.0 ft. (9.8 m)
6	Not Available	30.5 ft. (9.3 m)

(ULCS636 pipe must be used for Canada.)

Indoor Direct Vent

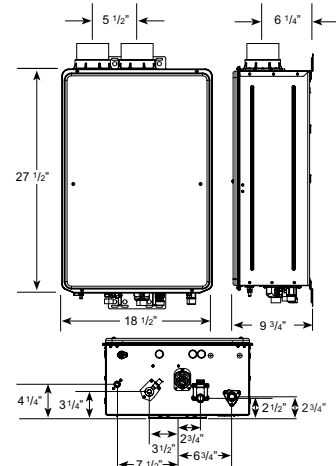

Outdoor

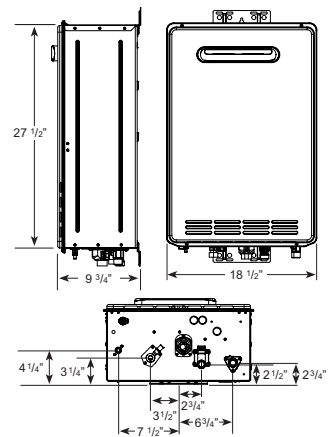

In keeping with its policy of continuous progress and product improvement, Rheem reserves the right to make changes without notice.

Rheem Water Heating • 101 Bell Road
Montgomery, Alabama 36117-4305 • 1.800.621.5622

Rheem Canada Ltd./Ltée • 125 Edgeware Road, Unit 1
Brampton, Ontario L6Y 0P5 • 1.800.268.6966



INTEGRATED AIR & WATER

Rheem.com

PRINTED IN U.S.A. 12/12 WP FORM NO. TK-901C Rev. 5