

RADIATION SHIELDING LEAD LINED DOOR FRAMES

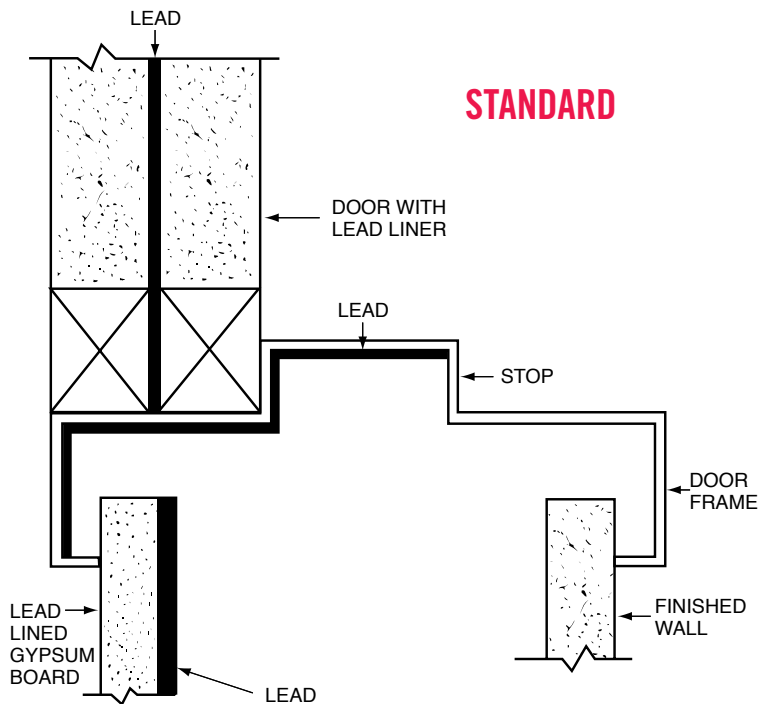

STANDARD LEAD LINED DOOR FRAMES

Radiation Protection Products' Standard Lead Lined Door Frames consist of 16-gauge steel, a 2" face, and a 5-7/8" jamb depth. They are set up and welded and can accommodate up to 1/2" thick lead lining. Our Lead Lined Door Frames are shipped with steel stud anchors that can be attached to the door frame either by welding or with steel fasteners if the lead lining does not exceed 3/32" thick.

We require the use of an Angle Iron for added support on Lead Lined Door Frames that require 1/8" thick lead or higher. These Angle Irons can be spot welded to the steel stud or pre-drilled and bolted to the steel stud.

*We do offer angle irons on our lead lined door frames that are below 1/8" thick lead if requested.

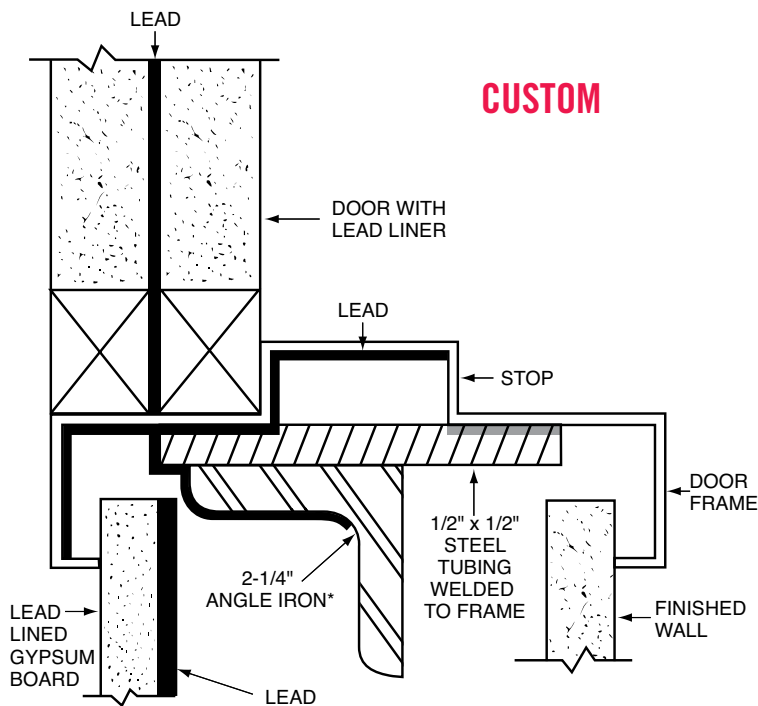

CUSTOM LEAD LINED DOOR FRAMES

We can supply knock down, slip and other lead lined frames upon request. Our Lead Lined Frames can also be equipped with the type of anchors necessary for any given situation (wood stud anchors, masonry strap anchors, etc.). Although our standard Lead Lined Door Frames consist of 16-gauge steel, we offer frames at 14-gauge and 12-gauge as well.

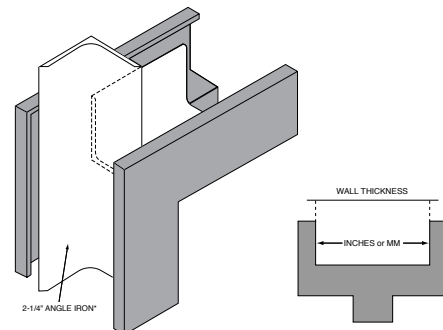

1000 Superior Boulevard, Suite 310 • Wayzata, MN 55391
1.888.RINGRPP (1.888.746.4777) • TOLL FREE FAX: 1.866.554.8445
www.radiationproducts.com

servicing the nation's lead needs for over 50 years with a full line of radiation shielding products