

MTH PUMPS

C41 • C51 • C61 Series

- Capacities to 100 GPM
- Heads to 140 Feet
- Horizontal Close Coupled



C SERIES PUMPS



MTH PUMPS

401 West Main Street • Plano, IL 60545-1436
Phone: 630-552-4115 • Fax: 630-552-3688
Email: SALES@MTHPUMPS.COM
<http://WWW.MTHPUMPS.COM>

MTH PUMPS

C Series Close Coupled Centrifugal Pumps

C41 • C51 • C61 close-coupled centrifugal pumps from MTH provide economical performance for 5 to 100 GPM applications requiring heads to 140 feet. By combining the latest concepts in pump design with precision manufacturing, the C Series pumps deliver excellent efficiency and low NPSH requirements. Efficient manufacturing processes and highly optimized mechanical designs control costs. Maintenance costs are kept to a minimum by combining a highly serviceable design with quality components to provide a long service life.

Impeller Design

C Series semi-open impellers allow the pump to pass small solids and fibrous material while close running tolerances maintain efficiency and performance. Impellers are pre-trimmed to be non-overloading to the pump and motor size indicated.

NPSH Requirements

C Series centrifugal pumps meet low net positive suction head requirements (NPSHR) without sacrificing efficiency. This is achieved by low fluid inlet velocity and gentle acceleration to peripheral velocities.

Mechanical Seal Box

The large seal chamber provides a wide fluid passage area for maximum cooling of the seal faces and allows debris and gases to be flushed away.

Axial Balance System

The C Series pumps utilize a thrust balancing system which combines the advantages of both static and dynamic balancing techniques to reduce axial thrust and provide longer bearing life.

D3 Motors

Similar to the T31 Series, the C Series takes advantage of our custom manufactured dual face D3 motors that incorporate a 304 stainless steel shaft and heavy-duty bearing. The stainless steel shaft eliminates the necessity of a shaft sleeve, thereby reducing the parts

count and simplifying maintenance and servicing procedures. All D3 motors also feature a two-pole 50/60Hz rating, as well as CE Mark approval useful for OEM's with worldwide customers. The three-phase versions of the D3 motors feature a compact TEFC enclosure and a range from 1/3 to 3HP. The single phase D3 motors have an ODP enclosure and a range from 1/3 to 2HP.

Adjustable Casing

C Series pump casings are axially adjustable allowing the use of custom impellers for OEM applications and to allow restoration of performance by closing up the internal clearances that develop over the course of a unit's extended service life.

Optional Features

Construction Materials

C Series pumps are also available in all bronze construction. Seal elastomer and "O" ring gaskets of Buna, EPR, and Viton are available. Carbon vs. Ceramic seal/seat materials are standard with graphite loaded silicon carbide seal/seat as an option.

Inlet Strainer

A 90° suction strainer with a replaceable screen is available for installation in the suction line to help prevent foreign materials from entering the pump. A cap at the bottom of the strainer can be easily and quickly removed for screen cleaning or replacement.

Engineering Specifications

Horizontal Close Coupled

The contractor shall furnish (and install as shown on the plans) an MTH (C41) (C51) (C61) Series horizontal close-coupled centrifugal type pump size _____ Stainless Steel construction. Each pump shall have a capacity of _____ GPM when operating at a total head of _____ feet. Suction pressure will be _____ feet with a liquid temperature of _____ °F.

The pump is to be furnished with 5/8" Type 2106 mechanical seal with stainless steel metal parts, (Buna) (Viton) elastomers, (ceramic seat and carbon primary ring) (Graphite loaded

silicon carbide seat and primary ring). A 304 stainless steel shaft shall be furnished in all pumps.

The pump casing shall be vertically split, end suction. (Top Discharge) (90° Discharge) (180° Discharge) (270° Discharge) The impeller shall use dynamic thrust balancing.

The pump shall be close-coupled to an 80mm "C" face _____ HP _____ phase _____ Hertz _____ Volt _____ RPM horizontal (Open Drip-Proof) (Totally Enclosed) motor with a CE Mark and UL rating.

STANDARD MATERIALS

PART	MATERIAL
Motor Bracket	Stainless Steel
Casing	Stainless Steel
Impeller	Stainless Steel
Motor Shaft	Stainless Steel
"O" Rings	Viton
Seals	Carbon/Viton
Seats	Ceramic/Viton

LIMITATIONS

Discharge Pressure	200 PSI
Suction Pressure* (Max)	145 PSI
Suction Pressure (Min.)	26" Hg Vac.
Speed** (Max.)	5500 RPM

Temperature

Standard Construction	-20° F
Ceramic Seal Seat - Water	+230° F
Graph. Imp. Silicon Carbide Seal Seat & Seal Flush	+250° F

Horsepower

D3 Motors - 3Ø	3 HP
D3 Motors - 1Ø	2 HP

* Consult factory for pressures over 145 psi

** With variable frequency drive @ 90Hz

C41 • C51 • C61 SERIES

Composite Curve

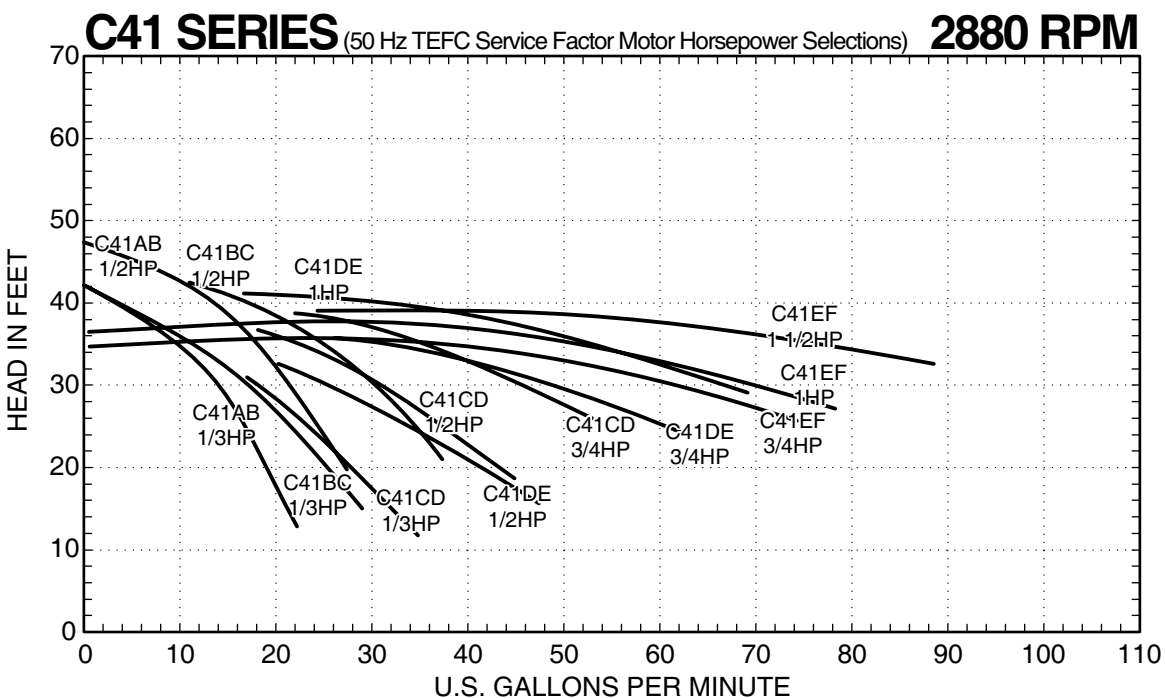
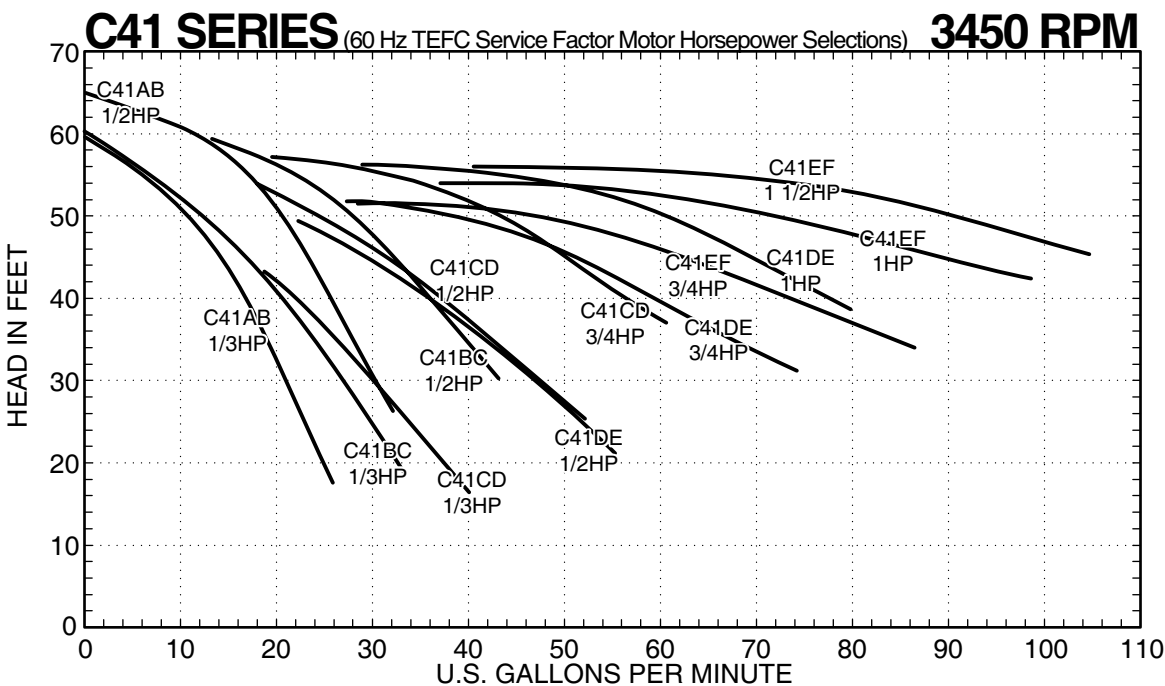

C41 SERIES PUMPS



MTH PUMPS

401 West Main Street • Plano, IL 60545-1436
 Phone: 630-552-4115 • Fax: 630-552-3688
 Email: SALES@MTHPUMPS.COM
<http://WWW.MTHPUMPS.COM>

C41 • C51 • C61 SERIES

Performance Curves

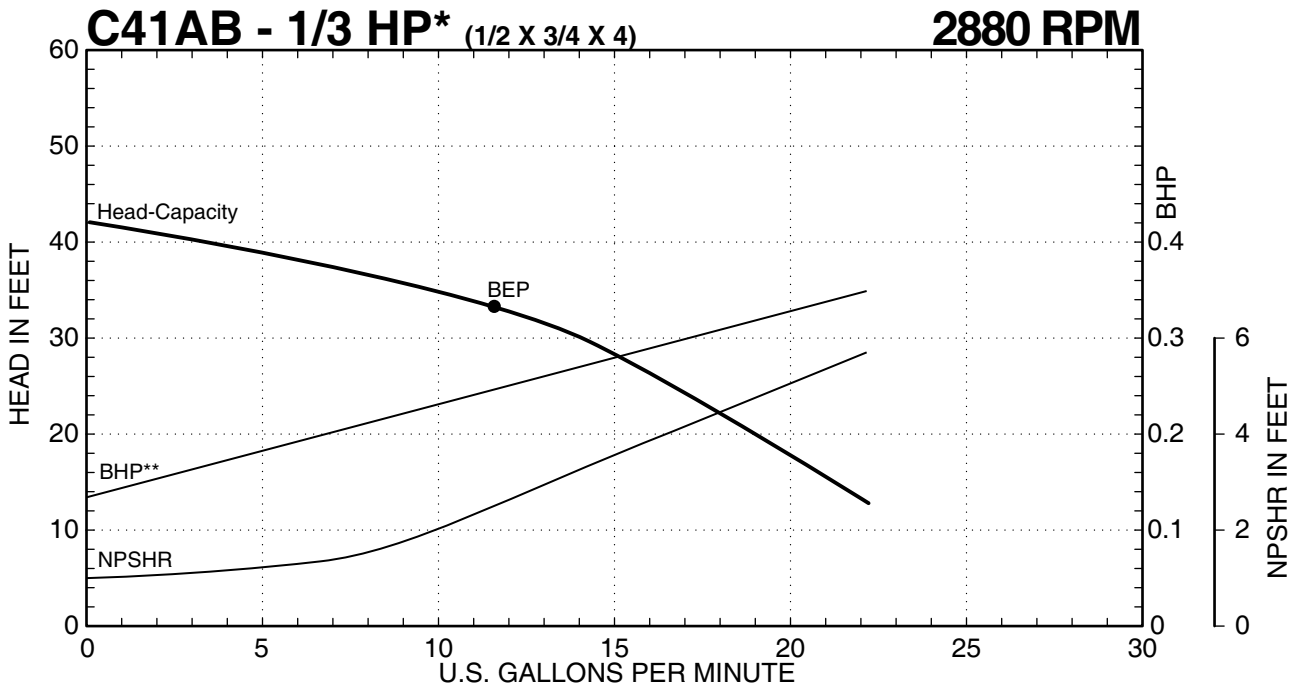
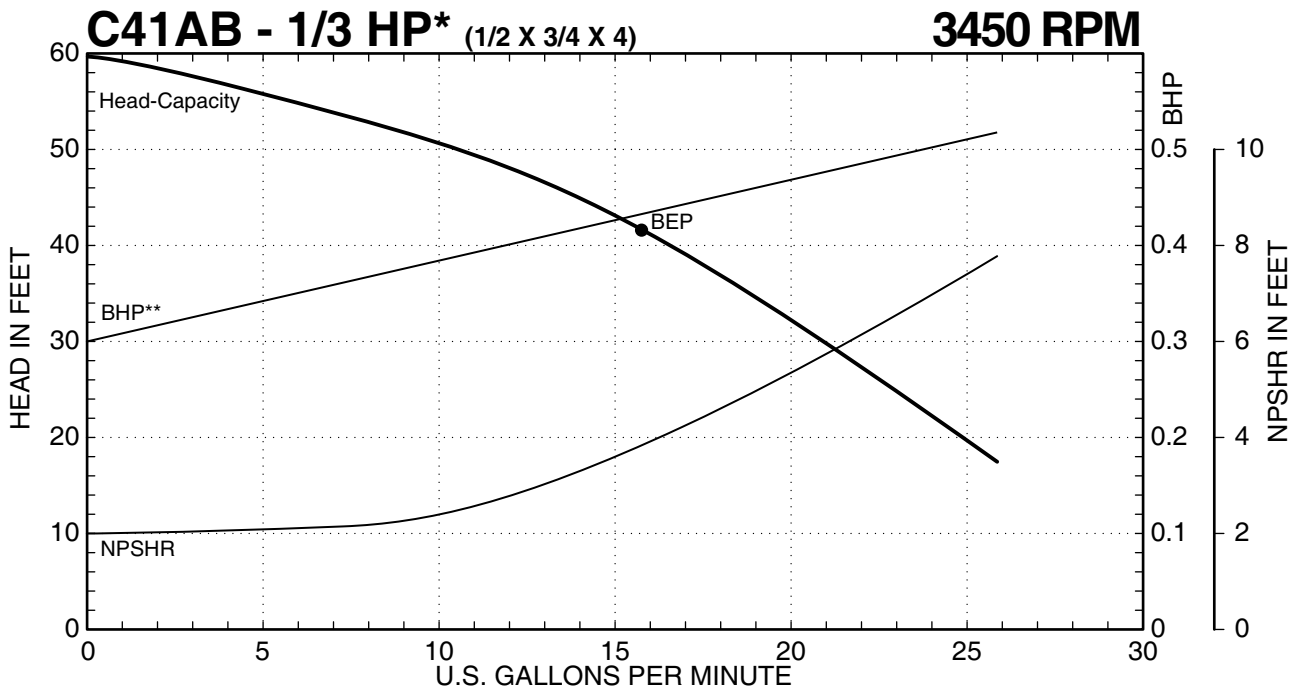

C41 SERIES PUMPS



MTH PUMPS

401 West Main Street • Plano, IL 60545-1436
 Phone: 630-552-4115 • Fax: 630-552-3688
 Email: SALES@MTHPUMPS.COM
 http://WWW.MTHPUMPS.COM

3 Phase 1/3 HP trim pump is furnished with a 1/2 HP 3/60/208-230/460V TEFC Motor.
 *High Service Factor Motor Horsepower Selections - See Standard Motor Guide and/or Motor Price Sheets for more information.
 **BHP data valid for 1.0 specific gravity fluids only.

C41 • C51 • C61 SERIES

Performance Curves

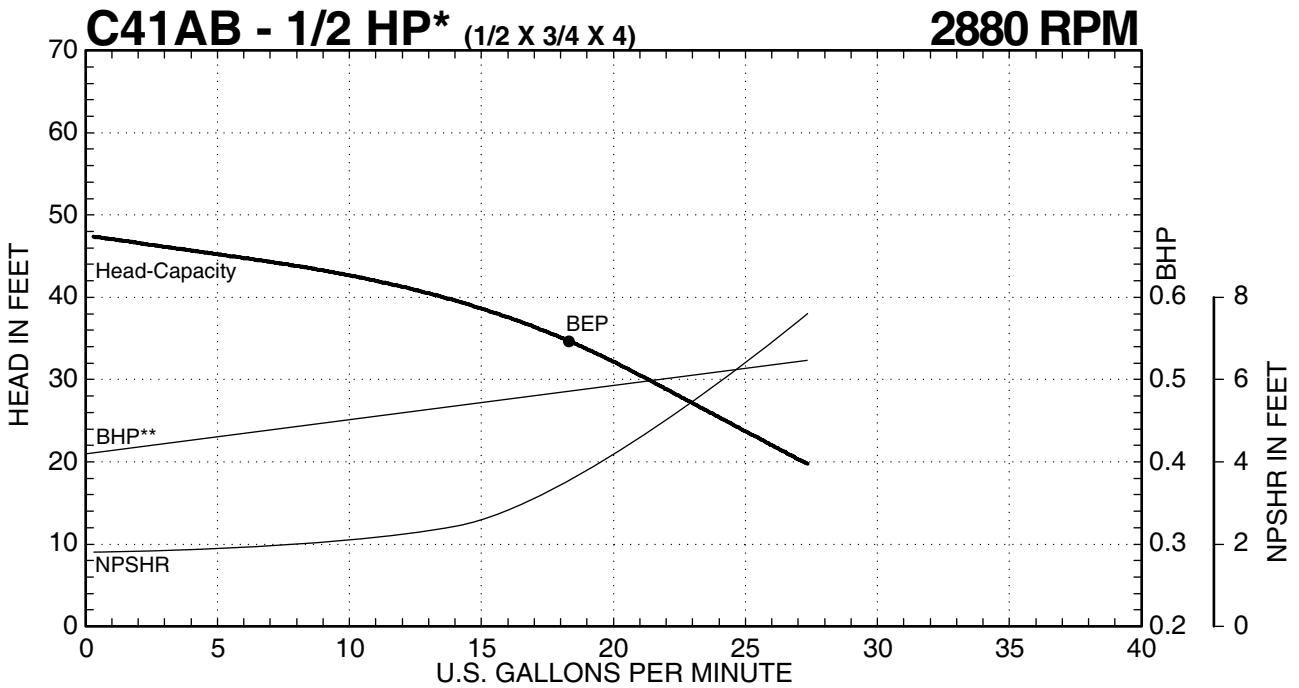
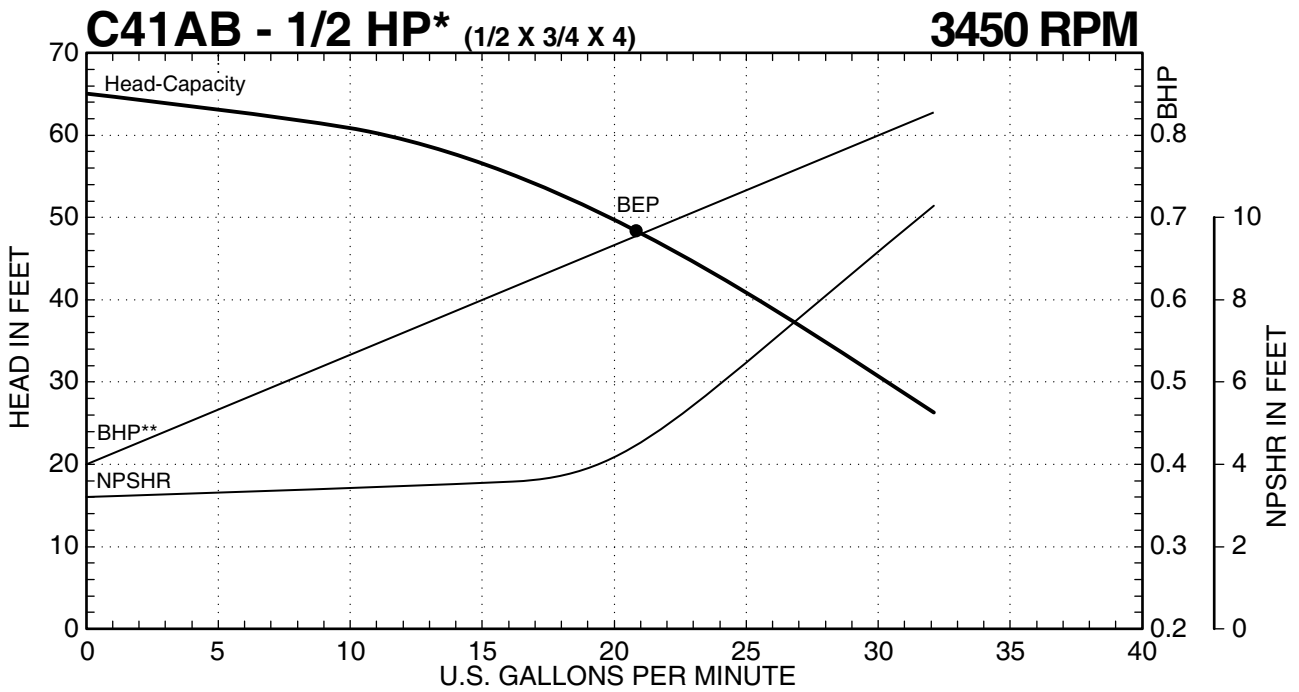

C41 SERIES PUMPS



MTH PUMPS

401 West Main Street • Plano, IL 60545-1436
 Phone: 630-552-4115 • Fax: 630-552-3688
 Email: SALES@MTHPUMPS.COM
 http://WWW.MTHPUMPS.COM

*High Service Factor Motor Horsepower Selections - See Standard Motor Guide and/or Motor Price Sheets for more information.
 **BHP data valid for 1.0 specific gravity fluids only.

C41 • C51 • C61 SERIES

Performance Curves

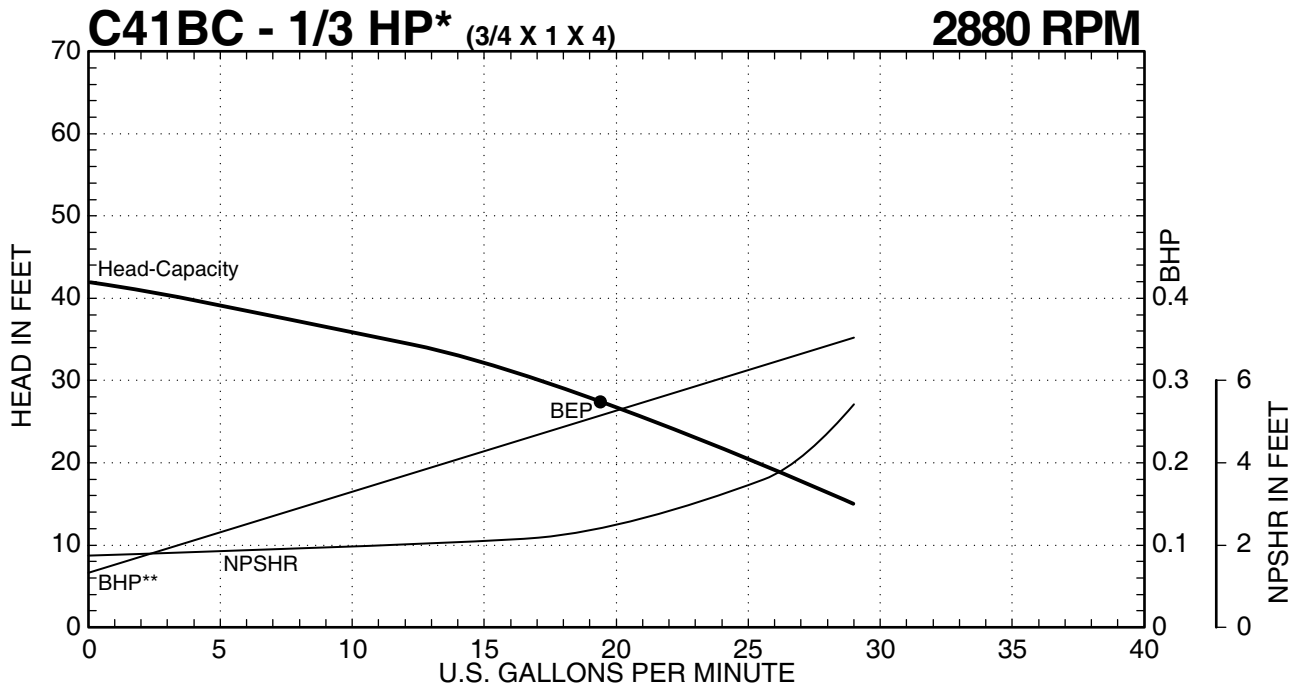
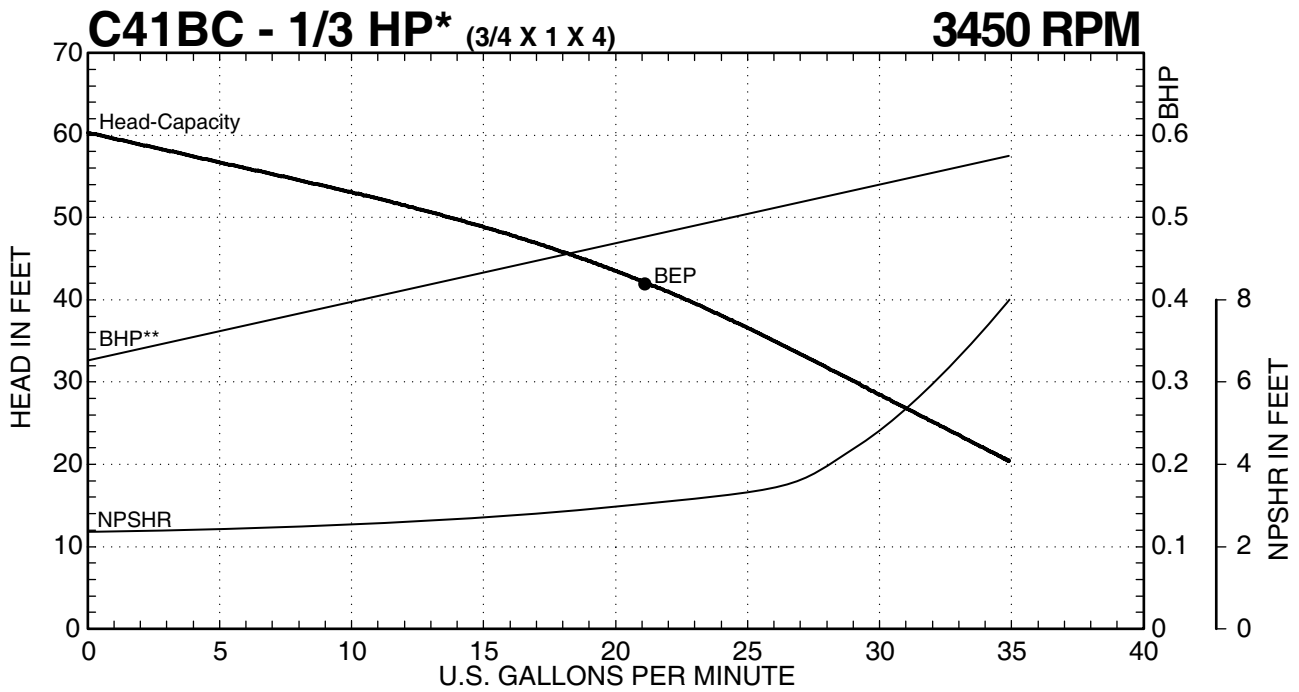

C41 SERIES PUMPS



MTH PUMPS

401 West Main Street • Plano, IL 60545-1436
 Phone: 630-552-4115 • Fax: 630-552-3688
 Email: SALES@MTHPUMPS.COM
 http://WWW.MTHPUMPS.COM

3 Phase 1/3 HP trim pump is furnished with a 1/2 HP 3/60/208-230/460V TEFC Motor.
 *High Service Factor Motor Horsepower Selections - See Standard Motor Guide and/or Motor Price Sheets for more information.
 **BHP data valid for 1.0 specific gravity fluids only.

C41 • C51 • C61 SERIES

Performance Curves

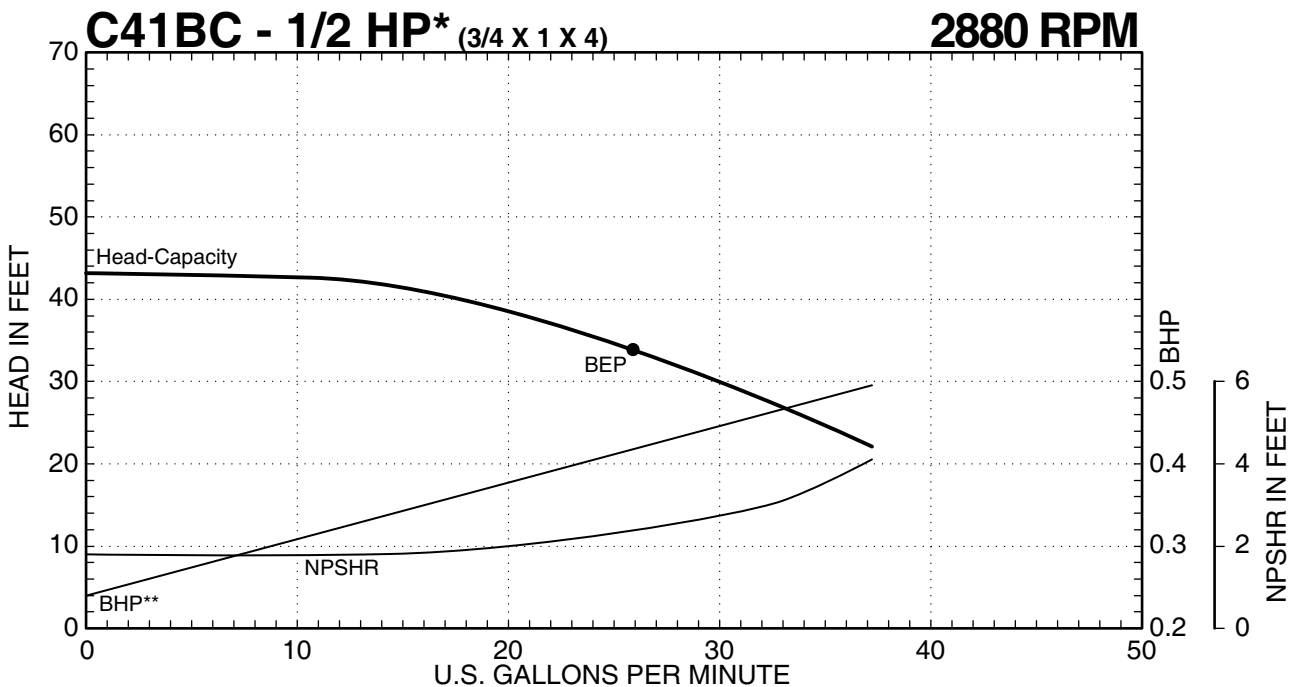
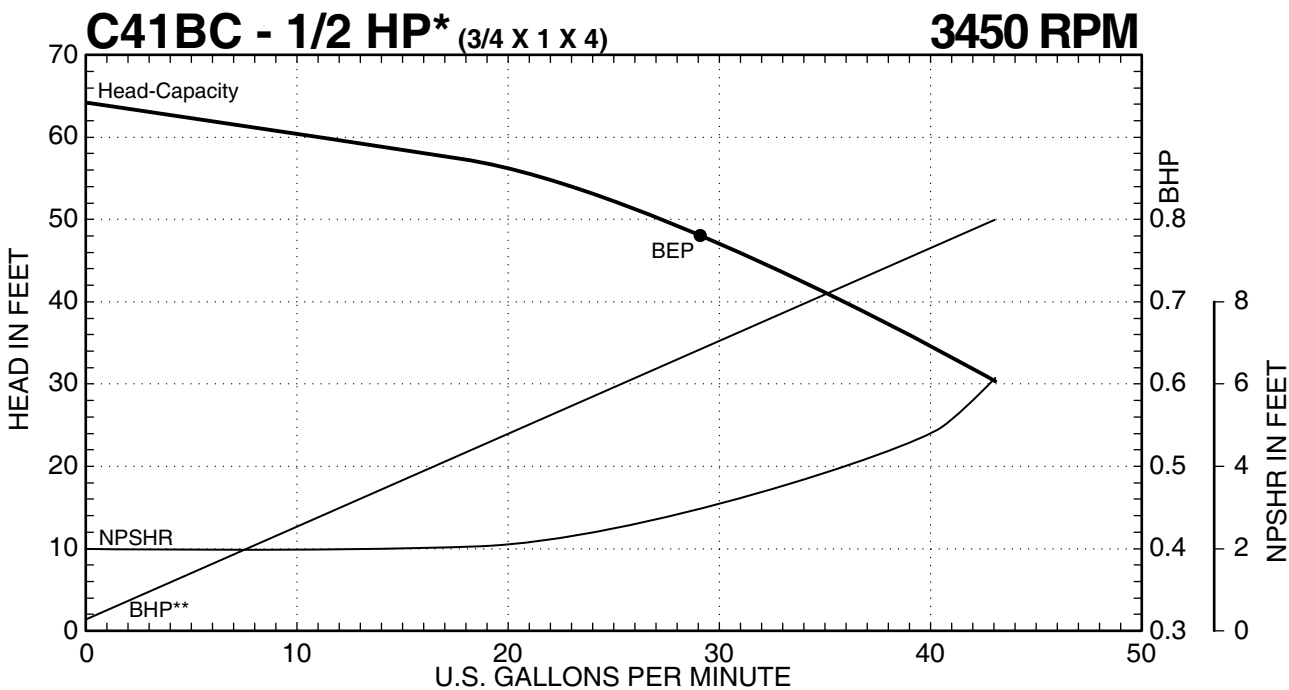

C41 SERIES PUMPS



MTH PUMPS

401 West Main Street • Plano, IL 60545-1436
 Phone: 630-552-4115 • Fax: 630-552-3688
 Email: SALES@MTHPUMPS.COM
 http://WWW.MTHPUMPS.COM

*High Service Factor Motor Horsepower Selections - See Standard Motor Guide and/or Motor Price Sheets for more information.
 **BHP data valid for 1.0 specific gravity fluids only.

C41 • C51 • C61 SERIES

Performance Curves

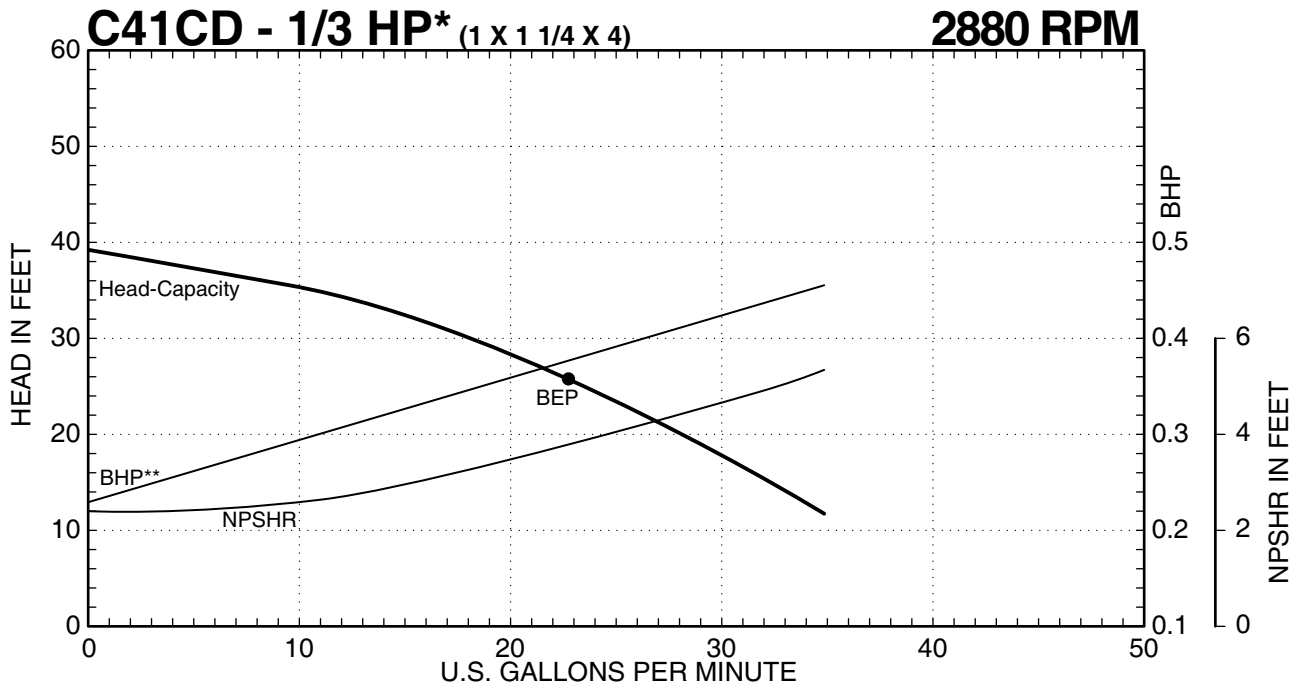
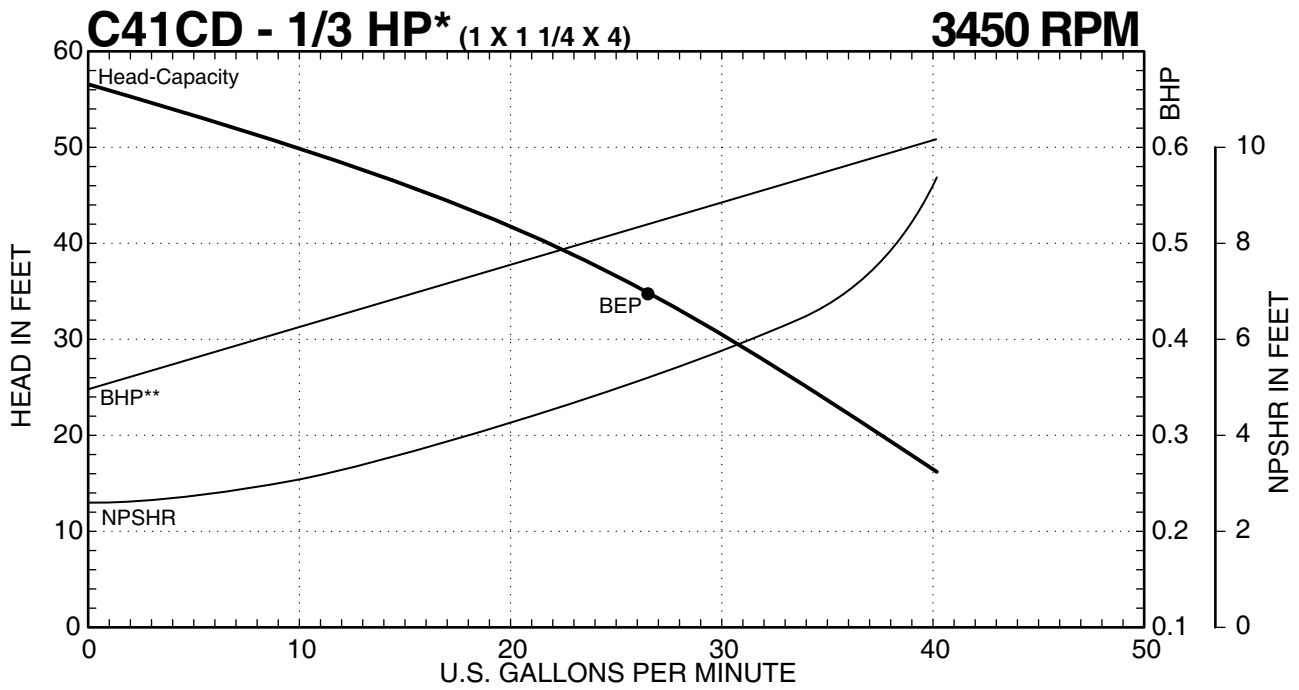

C41 SERIES PUMPS



MTH PUMPS

401 West Main Street • Plano, IL 60545-1436
 Phone: 630-552-4115 • Fax: 630-552-3688
 Email: SALES@MTHPUMPS.COM
 http://WWW.MTHPUMPS.COM

3 Phase 1/3 HP trim pump is furnished with a 1/2 HP 3/60/208-230/460V TEFC Motor.
 *High Service Factor Motor Horsepower Selections - See Standard Motor Guide and/or Motor Price Sheets for more information.
 **BHP data valid for 1.0 specific gravity fluids only.

C41 • C51 • C61 SERIES

Performance Curves

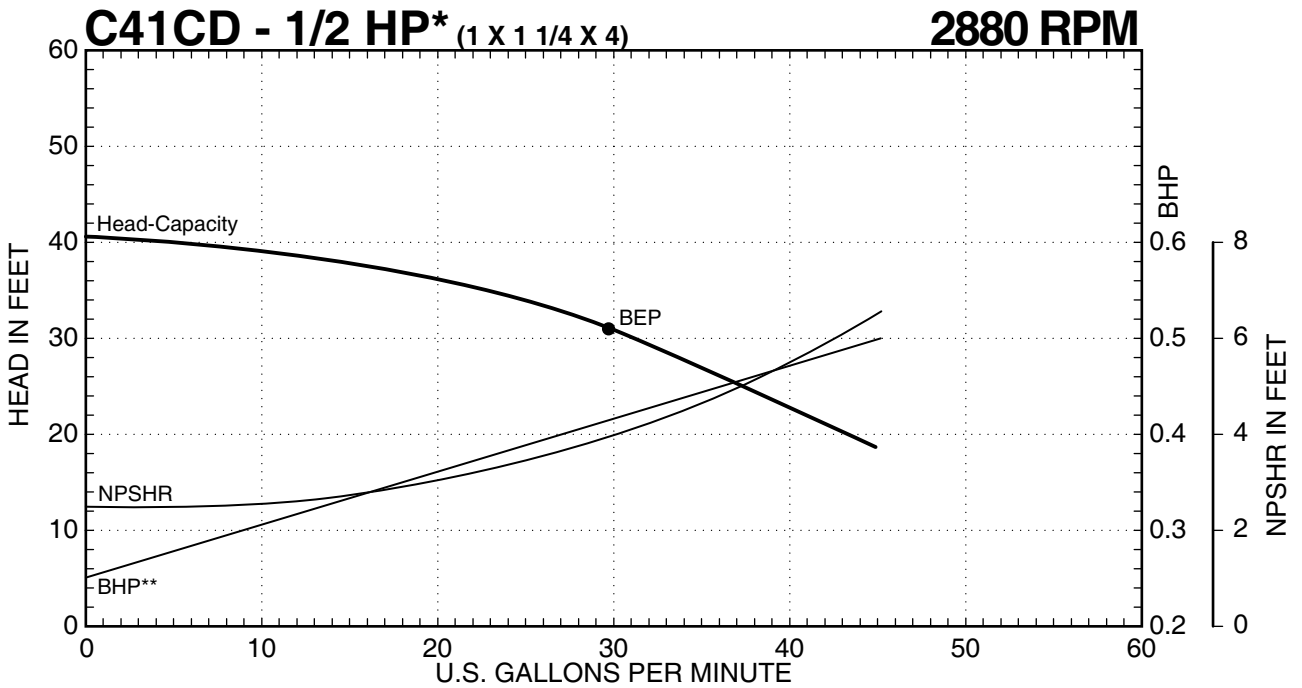
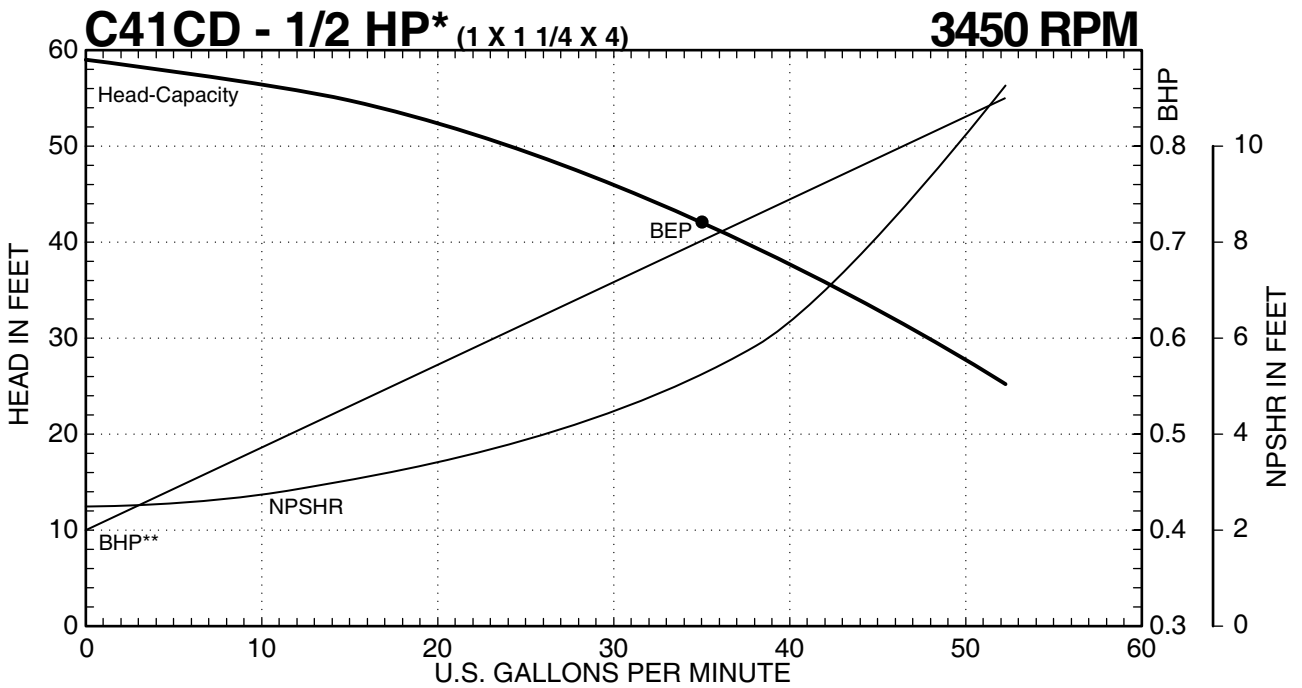

C41 SERIES PUMPS



MTH PUMPS

401 West Main Street • Plano, IL 60545-1436
 Phone: 630-552-4115 • Fax: 630-552-3688
 Email: SALES@MTHPUMPS.COM
 http://WWW.MTHPUMPS.COM

*High Service Factor Motor Horsepower Selections - See Standard Motor Guide and/or Motor Price Sheets for more information.
 **BHP data valid for 1.0 specific gravity fluids only.

C41 • C51 • C61 SERIES

Performance Curves

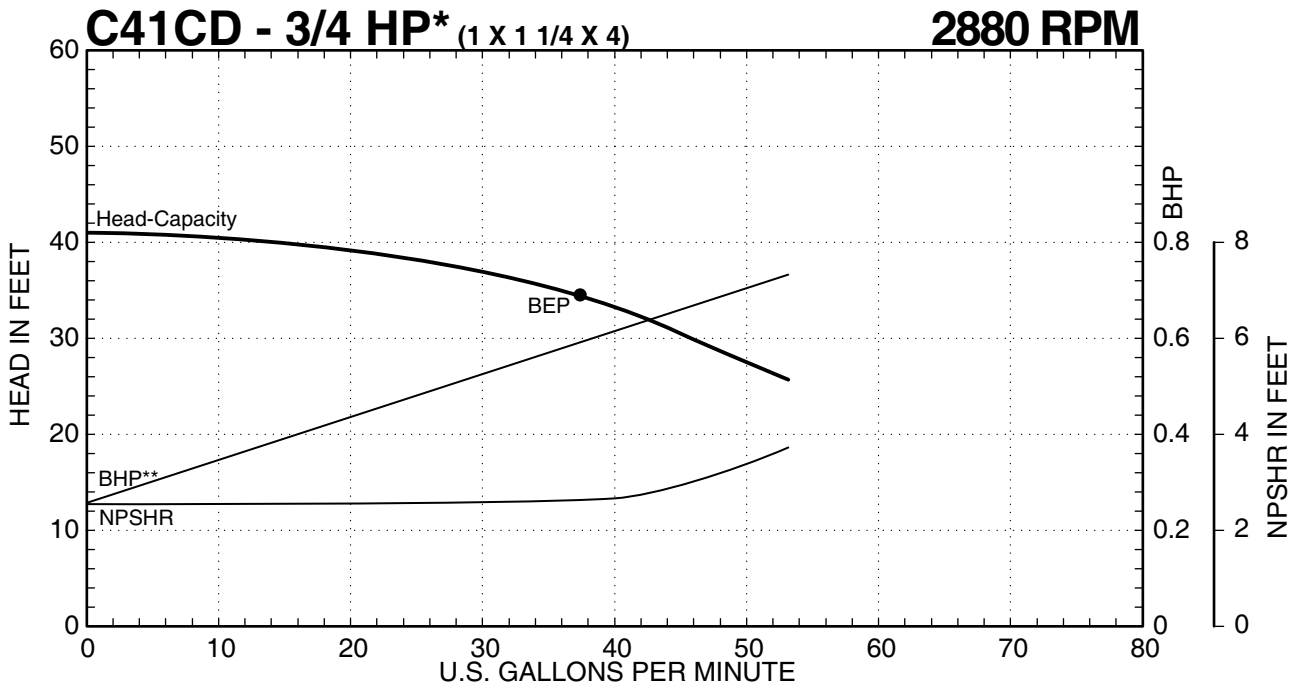
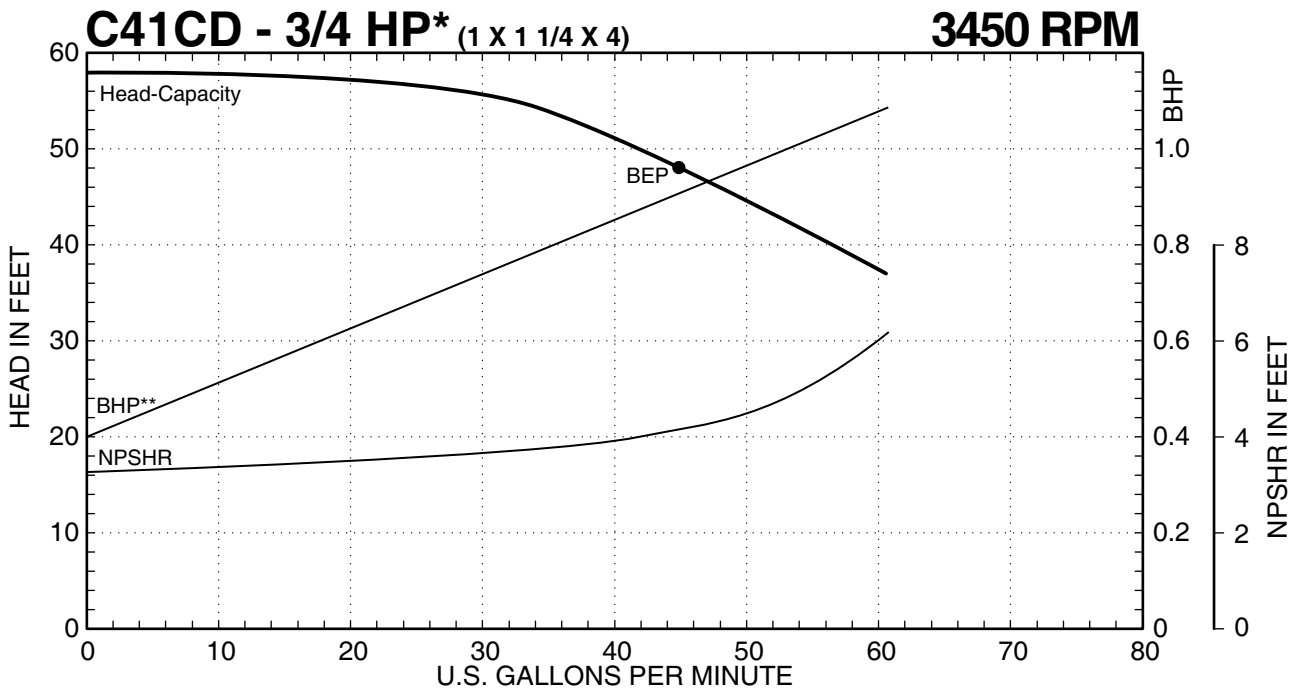

C41 SERIES PUMPS



MTH PUMPS

401 West Main Street • Plano, IL 60545-1436
 Phone: 630-552-4115 • Fax: 630-552-3688
 Email: SALES@MTHPUMPS.COM
 http://WWW.MTHPUMPS.COM

*High Service Factor Motor Horsepower Selections - See Standard Motor Guide and/or Motor Price Sheets for more information.
 **BHP data valid for 1.0 specific gravity fluids only.

C41 • C51 • C61 SERIES

Performance Curves

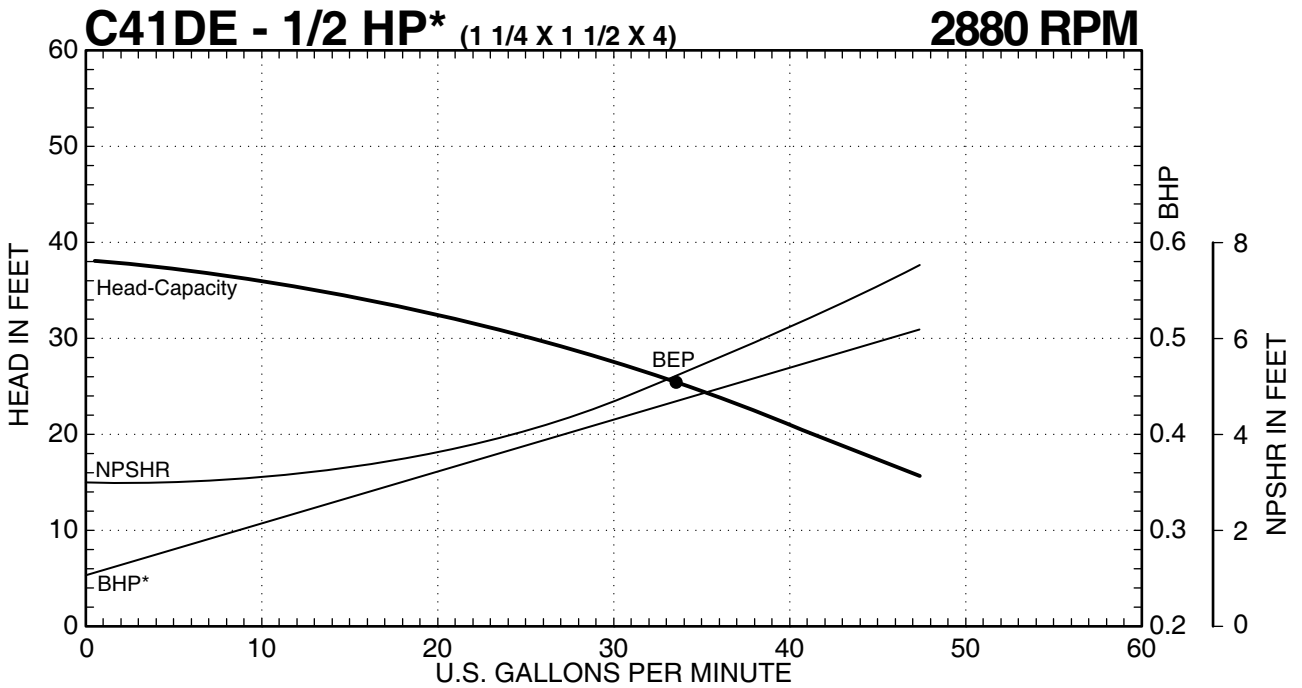
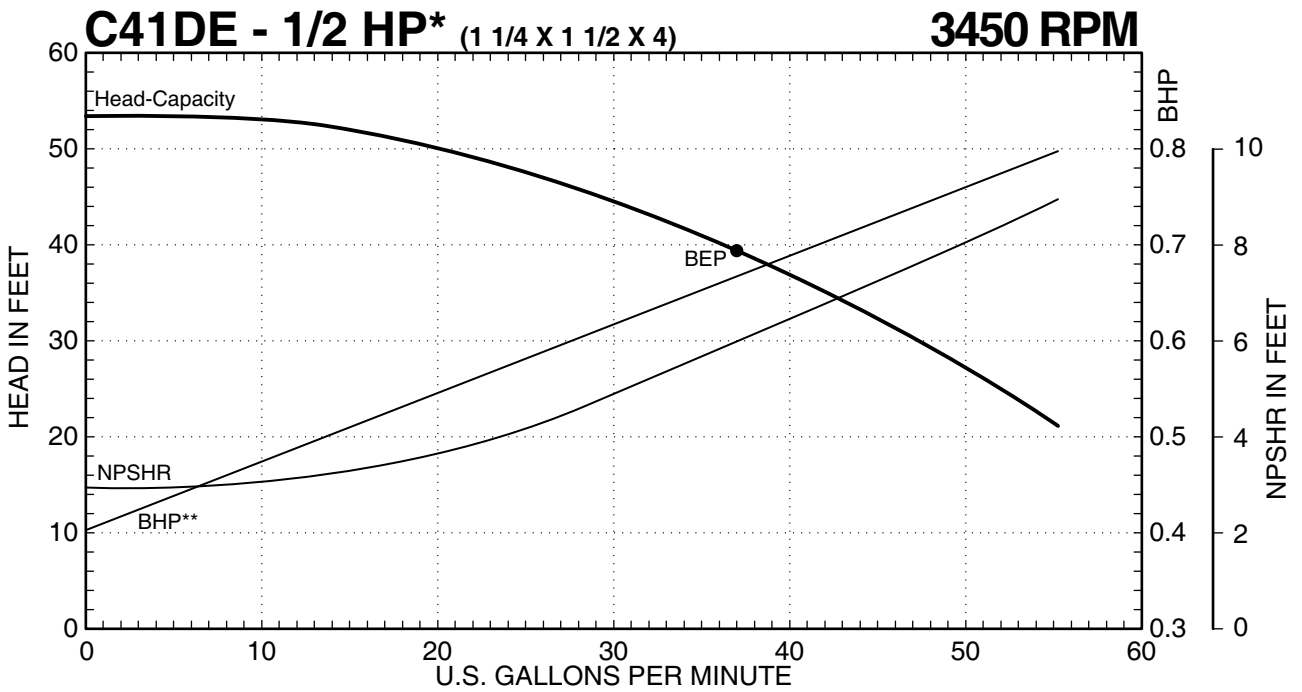

C41 SERIES PUMPS



MTH PUMPS

401 West Main Street • Plano, IL 60545-1436
 Phone: 630-552-4115 • Fax: 630-552-3688
 Email: SALES@MTHPUMPS.COM
 http://WWW.MTHPUMPS.COM

*High Service Factor Motor Horsepower Selections - See Standard Motor Guide and/or Motor Price Sheets for more information.
 **BHP data valid for 1.0 specific gravity fluids only.

C41 • C51 • C61 SERIES

Performance Curves

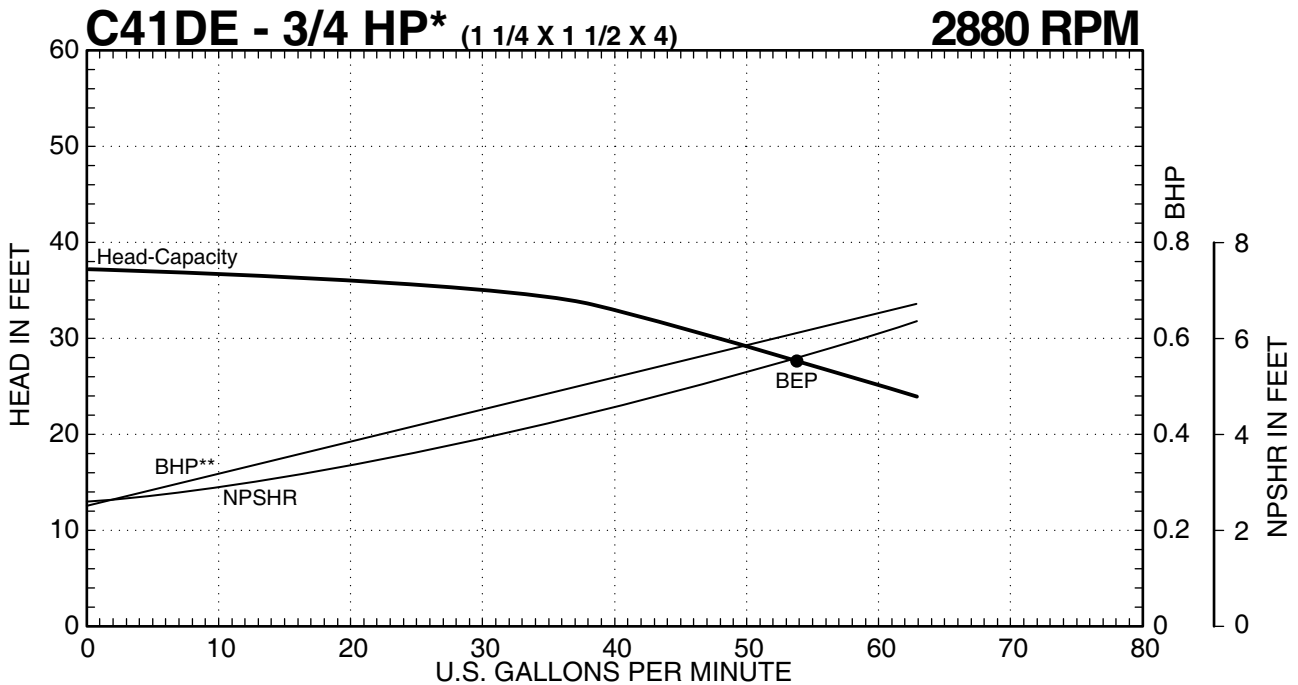
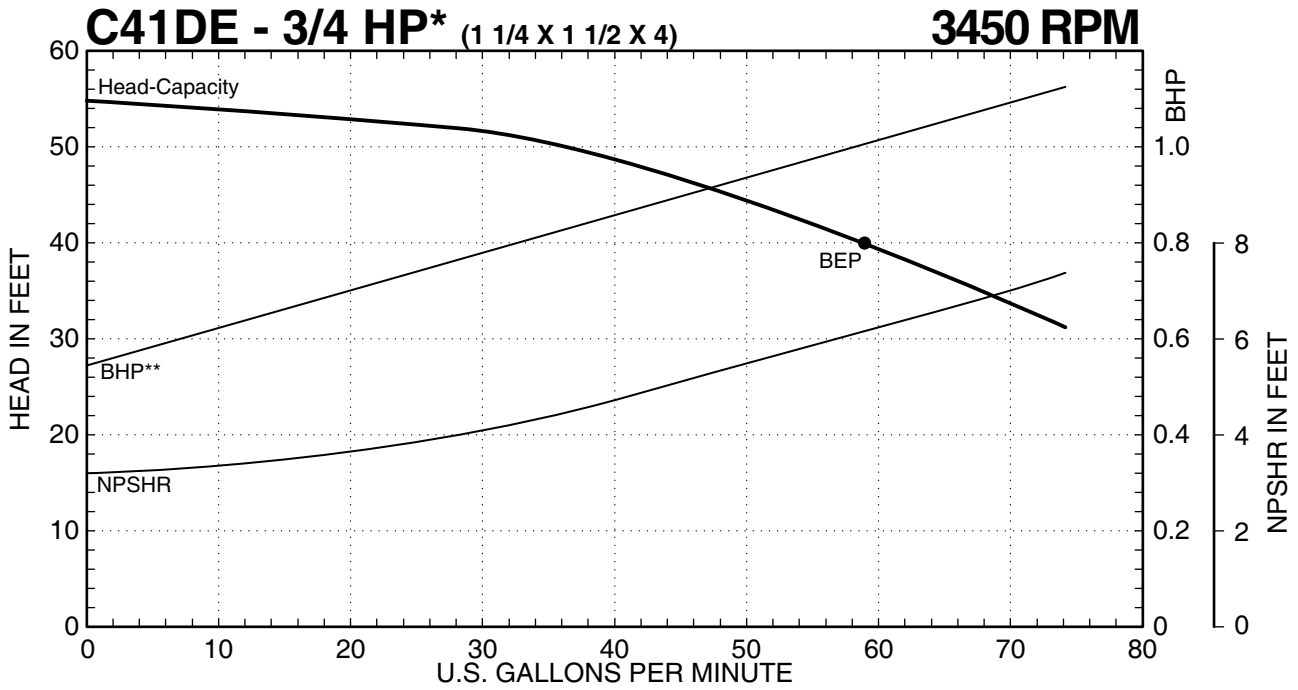

C41 SERIES PUMPS



MTH PUMPS

401 West Main Street • Plano, IL 60545-1436
 Phone: 630-552-4115 • Fax: 630-552-3688
 Email: SALES@MTHPUMPS.COM
 http://WWW.MTHPUMPS.COM

*High Service Factor Motor Horsepower Selections - See Standard Motor Guide and/or Motor Price Sheets for more information.
 **BHP data valid for 1.0 specific gravity fluids only.

C41 • C51 • C61 SERIES

Performance Curves

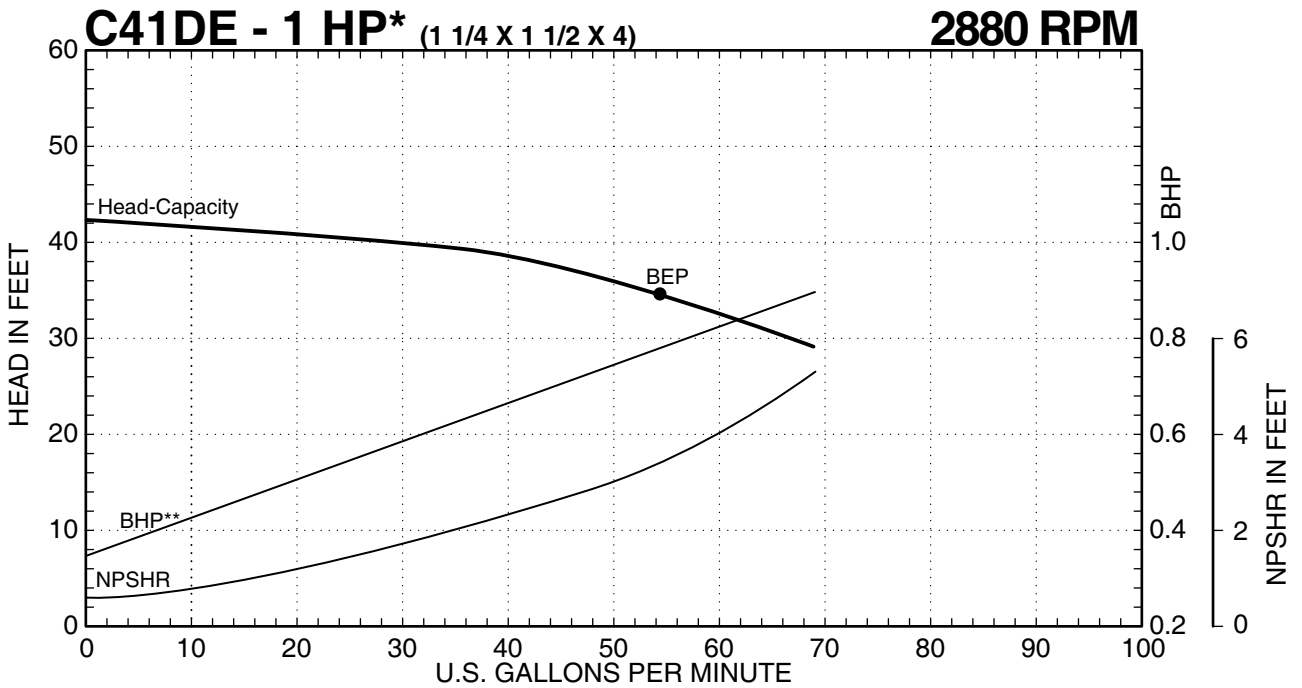
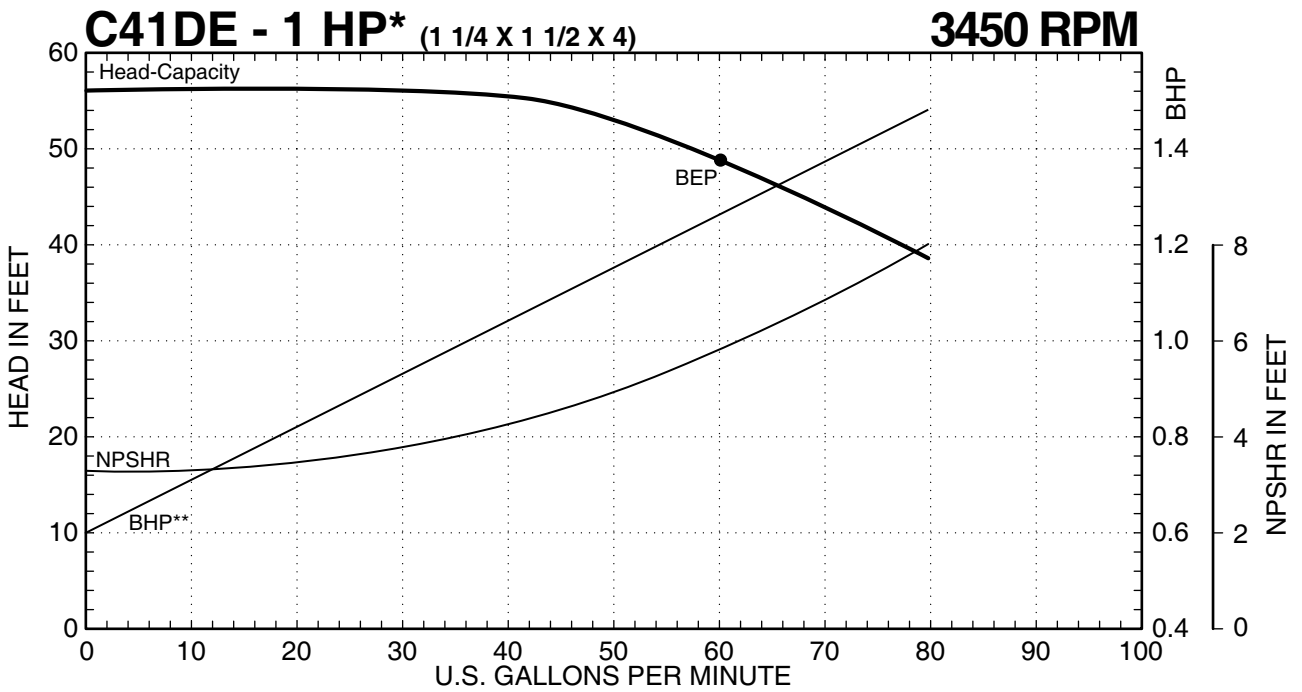

C41 SERIES PUMPS



MTH PUMPS

401 West Main Street • Plano, IL 60545-1436
 Phone: 630-552-4115 • Fax: 630-552-3688
 Email: SALES@MTHPUMPS.COM
 http://WWW.MTHPUMPS.COM

*High Service Factor Motor Horsepower Selections - See Standard Motor Guide and/or Motor Price Sheets for more information.
 **BHP data valid for 1.0 specific gravity fluids only.

C41 • C51 • C61 SERIES

Performance Curves

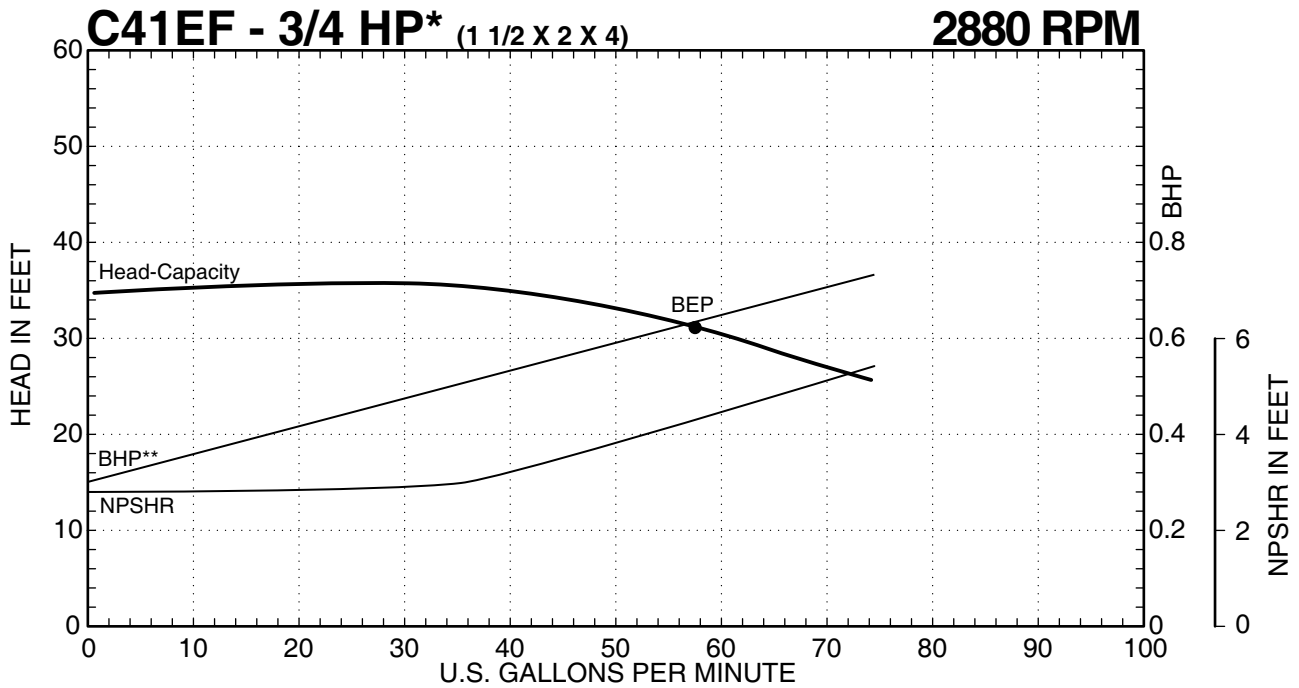
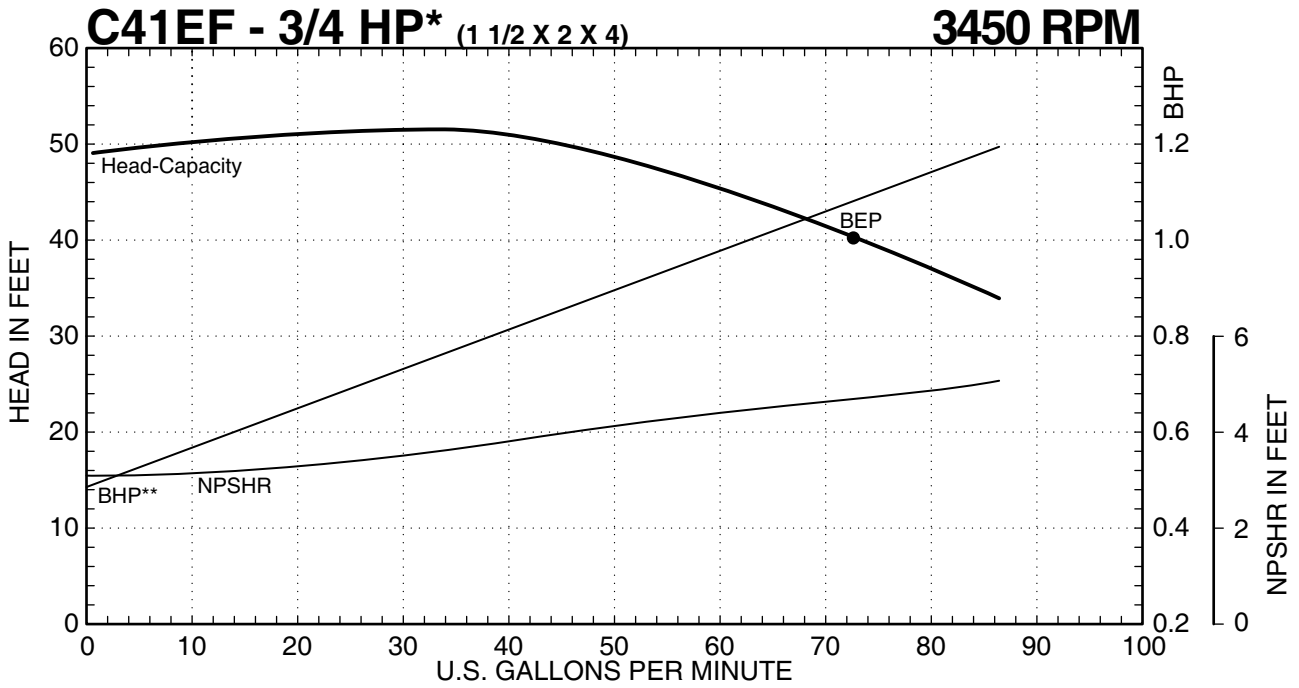

C41 SERIES PUMPS



MTH PUMPS

401 West Main Street • Plano, IL 60545-1436
 Phone: 630-552-4115 • Fax: 630-552-3688
 Email: SALES@MTHPUMPS.COM
<http://WWW.MTHPUMPS.COM>

*High Service Factor Motor Horsepower Selections - See Standard Motor Guide and/or Motor Price Sheets for more information.
 **BHP data valid for 1.0 specific gravity fluids only.

C41 • C51 • C61 SERIES

Performance Curves

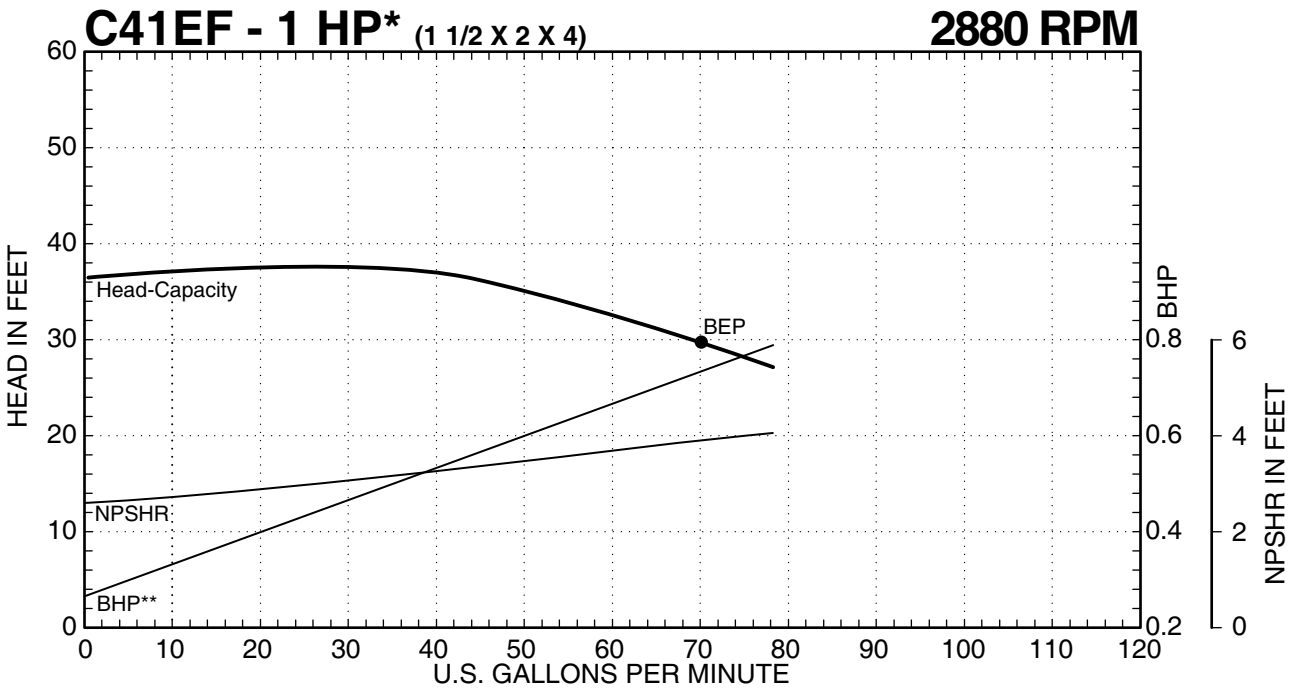
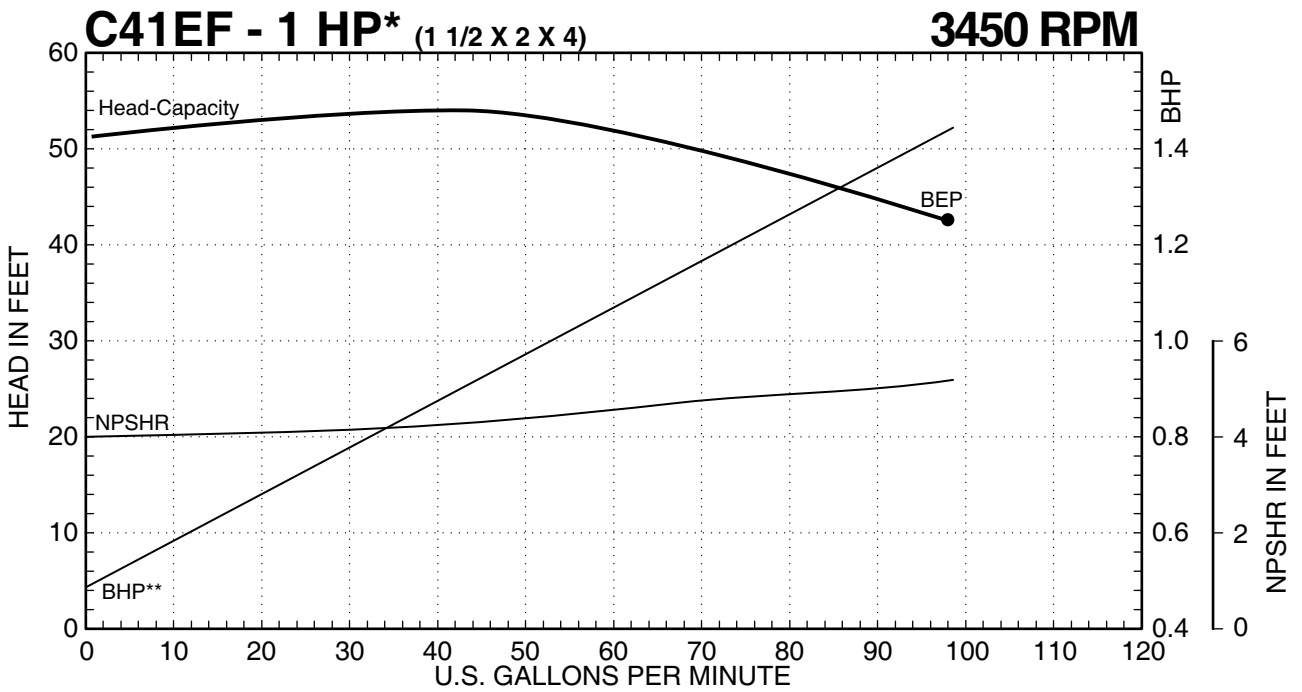

C41 SERIES PUMPS



MTH PUMPS

401 West Main Street • Plano, IL 60545-1436
 Phone: 630-552-4115 • Fax: 630-552-3688
 Email: SALES@MTHPUMPS.COM
 http://WWW.MTHPUMPS.COM

*High Service Factor Motor Horsepower Selections - See Standard Motor Guide and/or Motor Price Sheets for more information.
 **BHP data valid for 1.0 specific gravity fluids only.

C41 • C51 • C61 SERIES

Performance Curves

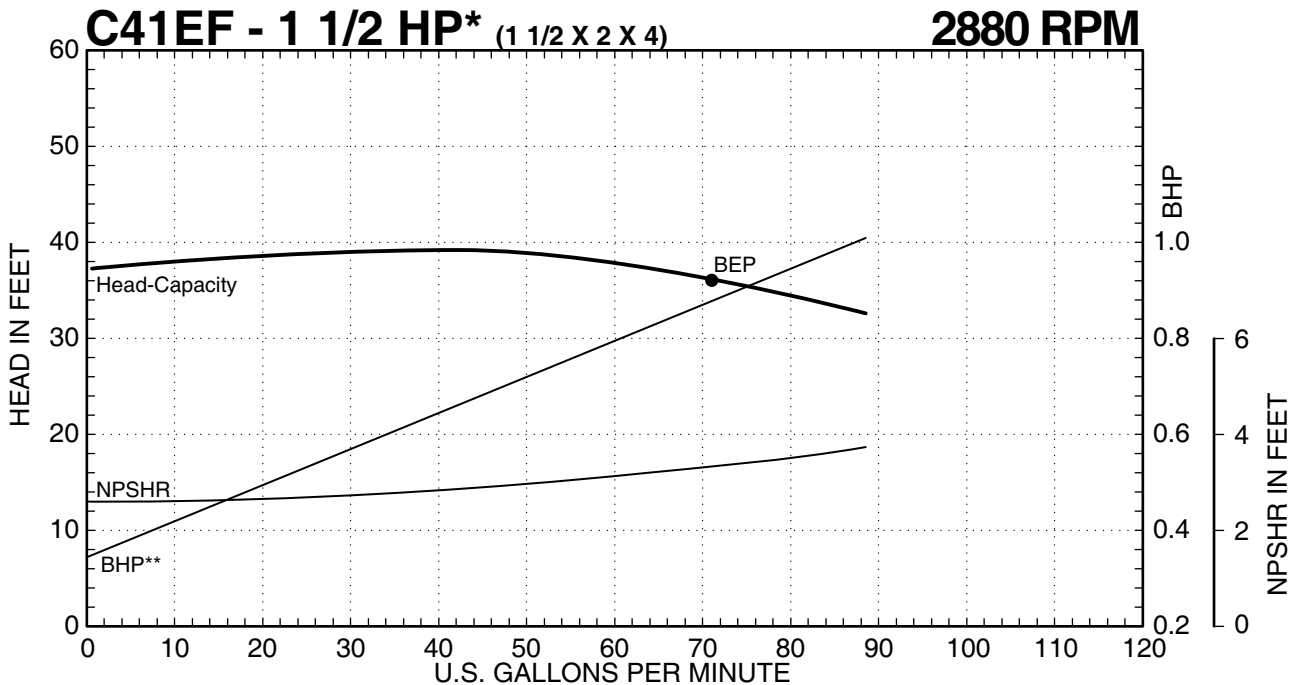
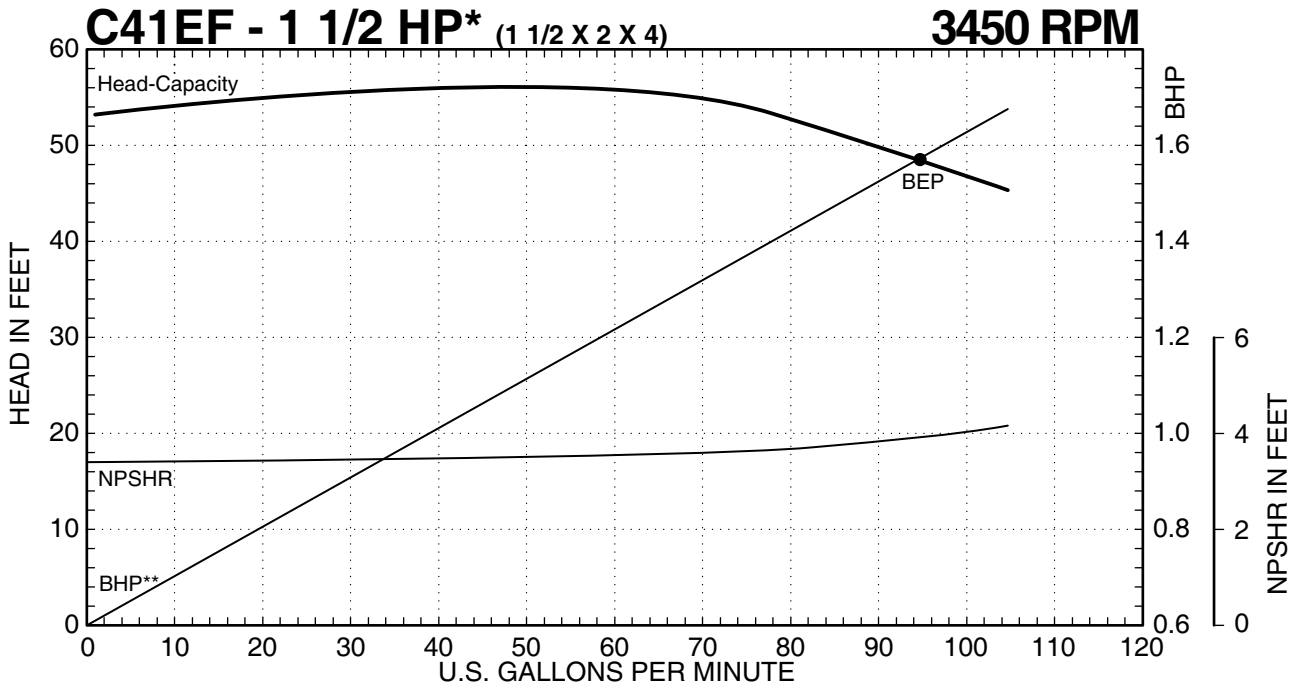

C41 SERIES PUMPS



MTH PUMPS

401 West Main Street • Plano, IL 60545-1436
 Phone: 630-552-4115 • Fax: 630-552-3688
 Email: SALES@MTHPUMPS.COM
<http://WWW.MTHPUMPS.COM>

*High Service Factor Motor Horsepower Selections - See Standard Motor Guide and/or Motor Price Sheets for more information.
 **BHP data valid for 1.0 specific gravity fluids only.

C41 • C51 • C61 SERIES

C41 Dimensions

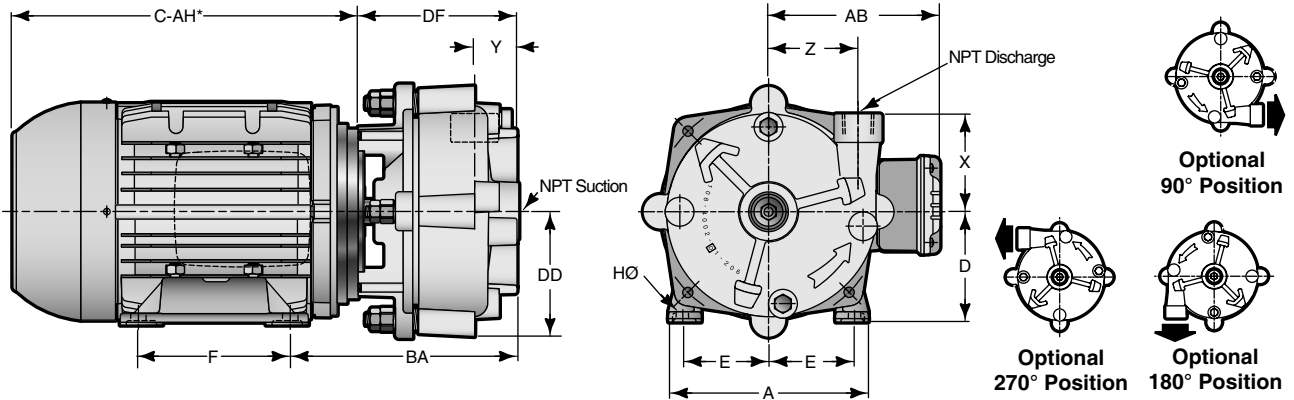

3 Phase TEFC Motors

Model	Pump Size			71 Frame (1/3 HP - 1 HP)										80 Frame (1 1/2 HP - 2HP)						
	Disch.	Suction	Imp. Ø	DD	DF	X	Y	Z	A	AB	D	E	F	BA	A	AB	D	E	F	BA
C41AB	1/2	3/4	4	3 1/4	4 3/16	2 9/16	1 3/16	2 5/16	5 1/4	5	2 13/16	2 3/16	3 9/16	6 3/16	---	---	---	---	---	---
C41BC	3/4	1	4	3 1/4	4 3/8	2 5/8	1 5/16	2 7/16	5 1/4	5	2 13/16	2 3/16	3 9/16	6 3/8	---	---	---	---	---	---
C41CD	1	1 1/4	4	3 1/4	4 9/16	2 3/4	1 1/2	2 9/16	5 1/4	5	2 13/16	2 3/16	3 9/16	6 9/16	---	---	---	---	---	---
C41DE	1 1/4	1 1/2	4	3 7/16	4 13/16	2 15/16	1 3/4	2 11/16	5 1/4	5	2 13/16	2 3/16	3 9/16	6 13/16	---	---	---	---	---	---
C41EF	1 1/2	2	4	3 5/16	5 3/16	2 15/16	2 1/16	2 13/16	5 1/4	5	2 13/16	2 3/16	3 9/16	7 3/16	6 1/8	5 1/8	3 1/8	2 7/16	3 15/16	7 3/8

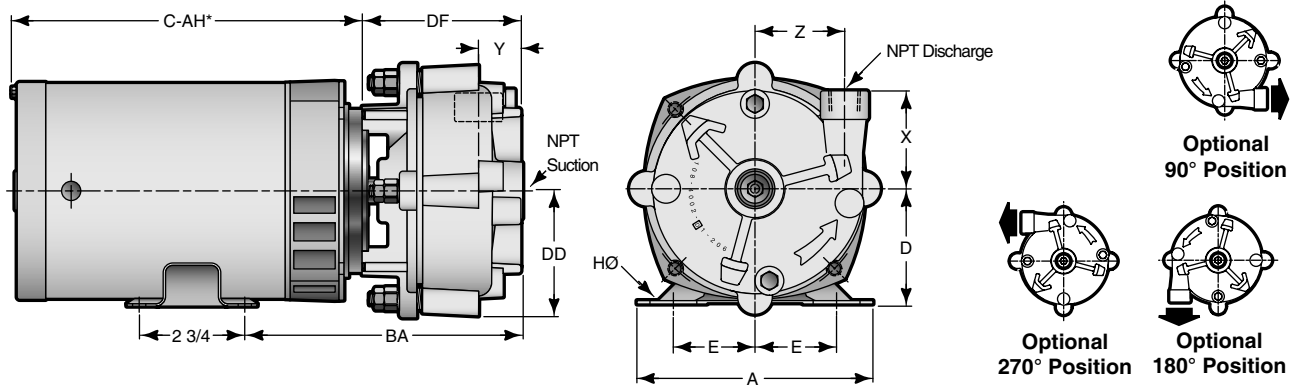

Single Phase ODP Motors

Model	Pump Size			48 Frame (1/3 - 1 HP)										56 Frame (1 1/2 - 2HP)					
	Disch.	Suction	Imp. Ø	DD	DF	X	Y	Z	A	D	E	H	BA	A	D	E	H	BA	
C41AB	1/2	3/4	4	3 1/4	4 3/16	2 9/16	1 3/16	2 5/16	6 1/8	3	2 1/8	5/16-18	7 3/16	---	---	---	---	---	
C41BC	3/4	1	4	3 1/4	4 3/8	2 5/8	1 5/16	2 7/16	6 1/8	3	2 1/8	5/16-18	7 3/4	---	---	---	---	---	
C41CD	1	1 1/4	4	3 1/4	4 9/16	2 3/4	1 1/2	2 9/16	6 1/8	3	2 1/8	5/16-18	7 9/16	---	---	---	---	---	
C41DE	1 1/4	1 1/2	4	3 7/16	4 13/16	2 15/16	1 3/4	2 11/16	6 1/8	3	2 1/8	5/16-18	7 13/16	---	---	---	---	---	
C41EF	1 1/2	2	4	3 5/16	5 3/16	2 15/16	2 1/16	2 13/16	6 1/8	3	2 1/8	5/16-18	8 3/16	6 9/16	3 1/2	2 7/16	5/16-18	8 3/16	

NOTES: All dimensions in inches. May vary ± 1/4 inches.
 Not for construction purposes unless certified.
 *See motor dimension (Section Motors) for "C-AH" dimension
 (Varies depending on motor enclosure).



MTH PUMPS
 401 West Main Street • Plano, IL 60545-1436
 Phone: 630-552-4115 • Fax: 630-552-3688
 Email: SALES@MTHPUMPS.COM
 http://WWW.MTHPUMPS.COM

C41 • C51 • C61 SERIES

Composite Curve

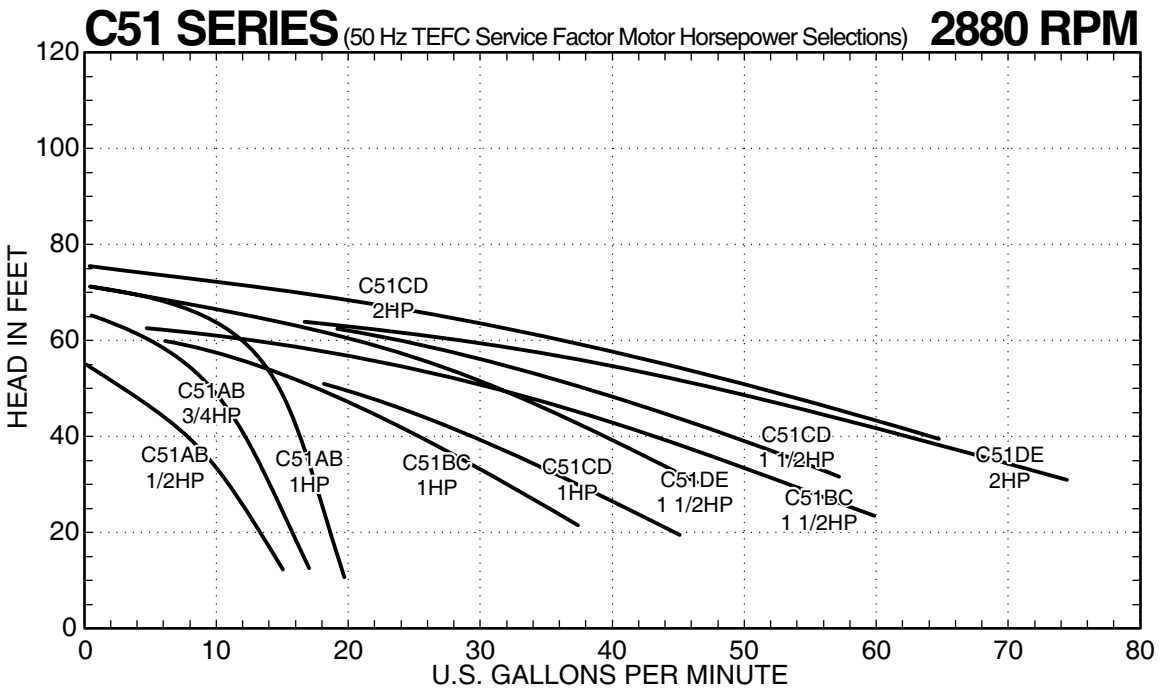
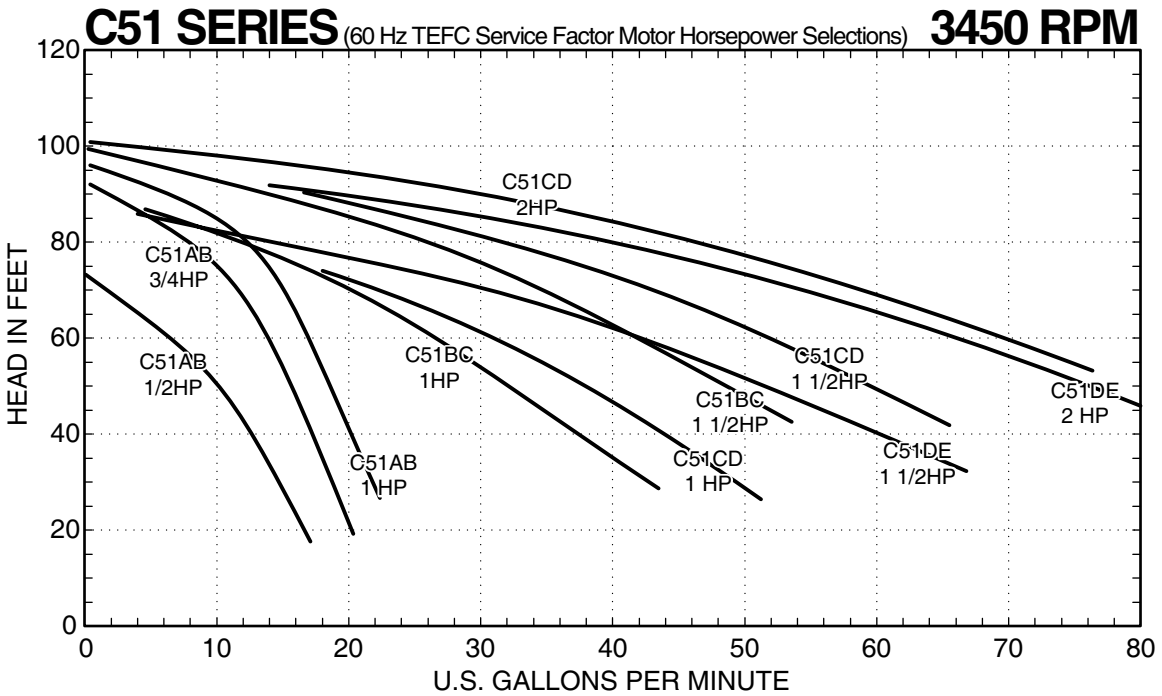

MTH PUMPS

401 West Main Street • Plano, IL 60545-1436
 Phone: 630-552-4115 • Fax: 630-552-3688
 Email: SALES@MTHPUMPS.COM
 http://WWW.MTHPUMPS.COM

C41 • C51 • C61 SERIES

Performance Curves

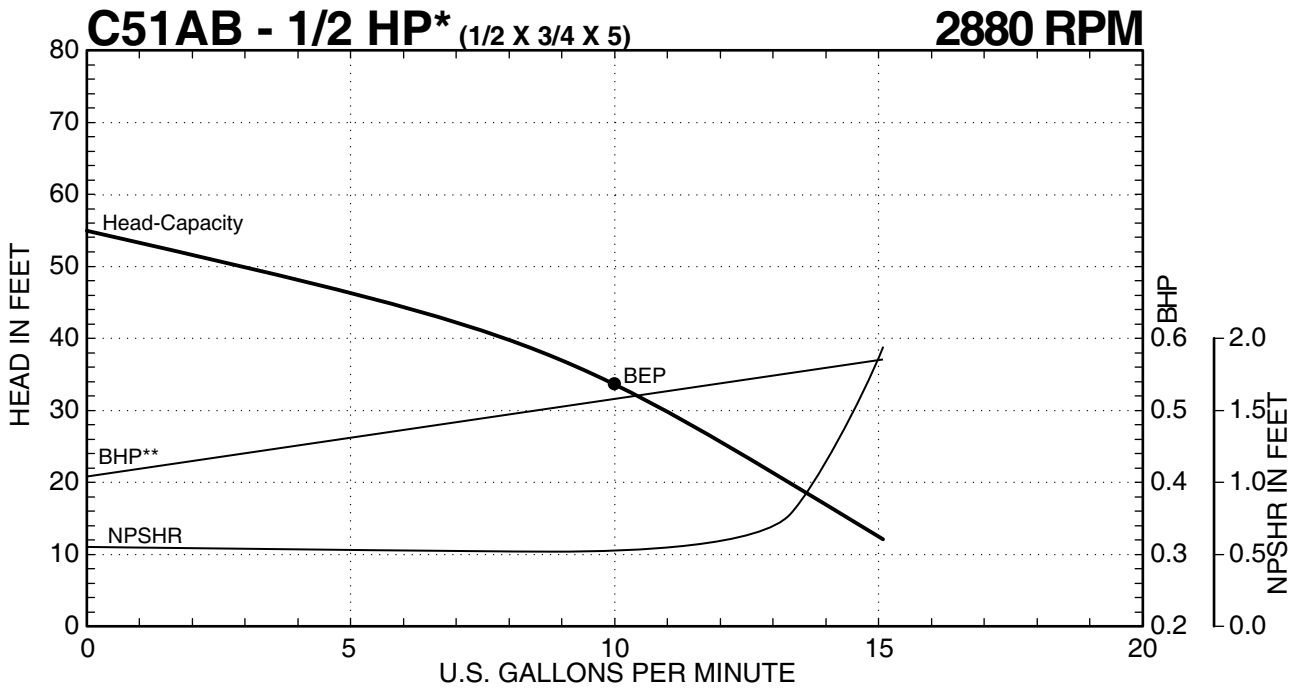
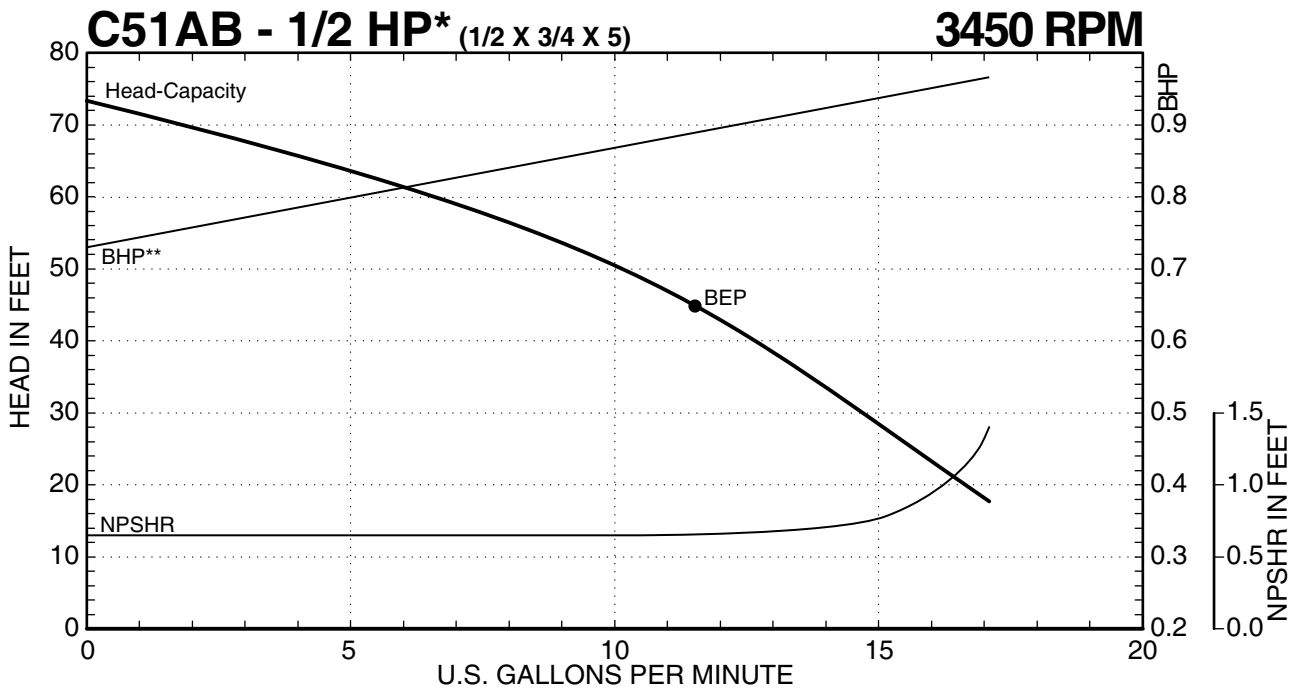

C51 SERIES PUMPS



MTH PUMPS

401 West Main Street • Plano, IL 60545-1436
 Phone: 630-552-4115 • Fax: 630-552-3688
 Email: SALES@MTHPUMPS.COM
 http://WWW.MTHPUMPS.COM

*High Service Factor Motor Horsepower Selections - See Standard Motor Guide and/or Motor Price Sheets for more information.
 **BHP data valid for 1.0 specific gravity fluids only.

C41 • C51 • C61 SERIES

Performance Curves

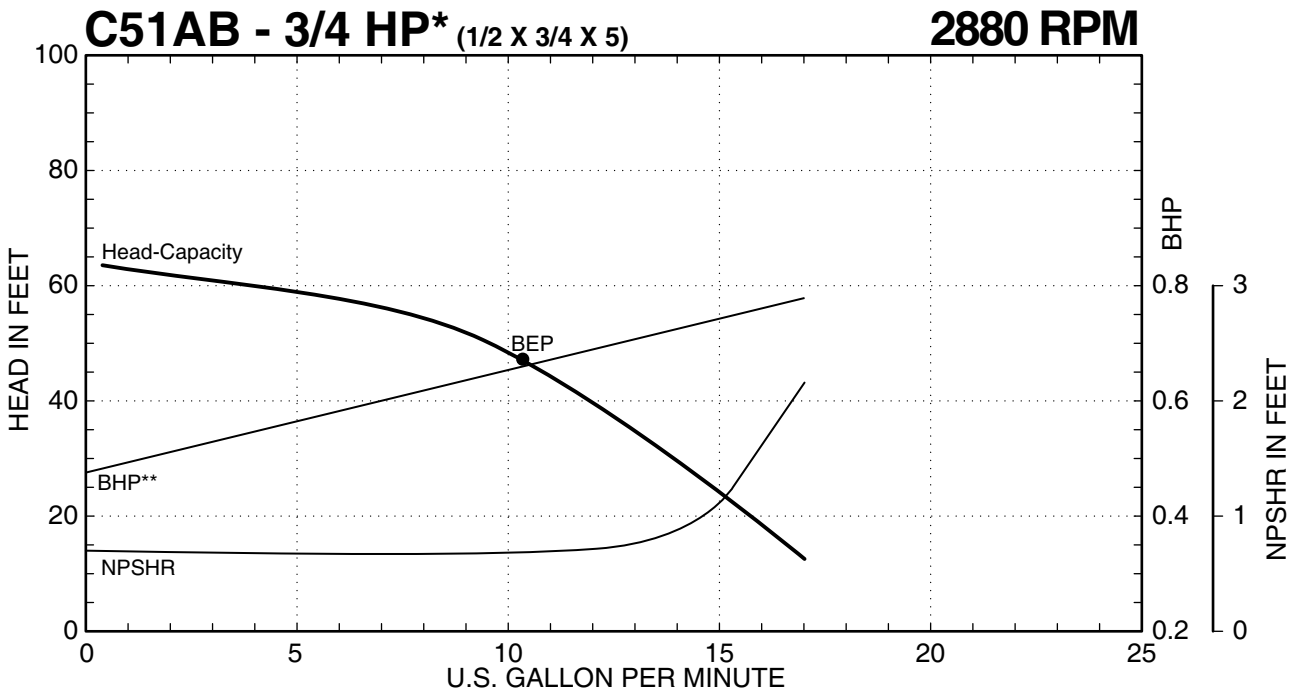
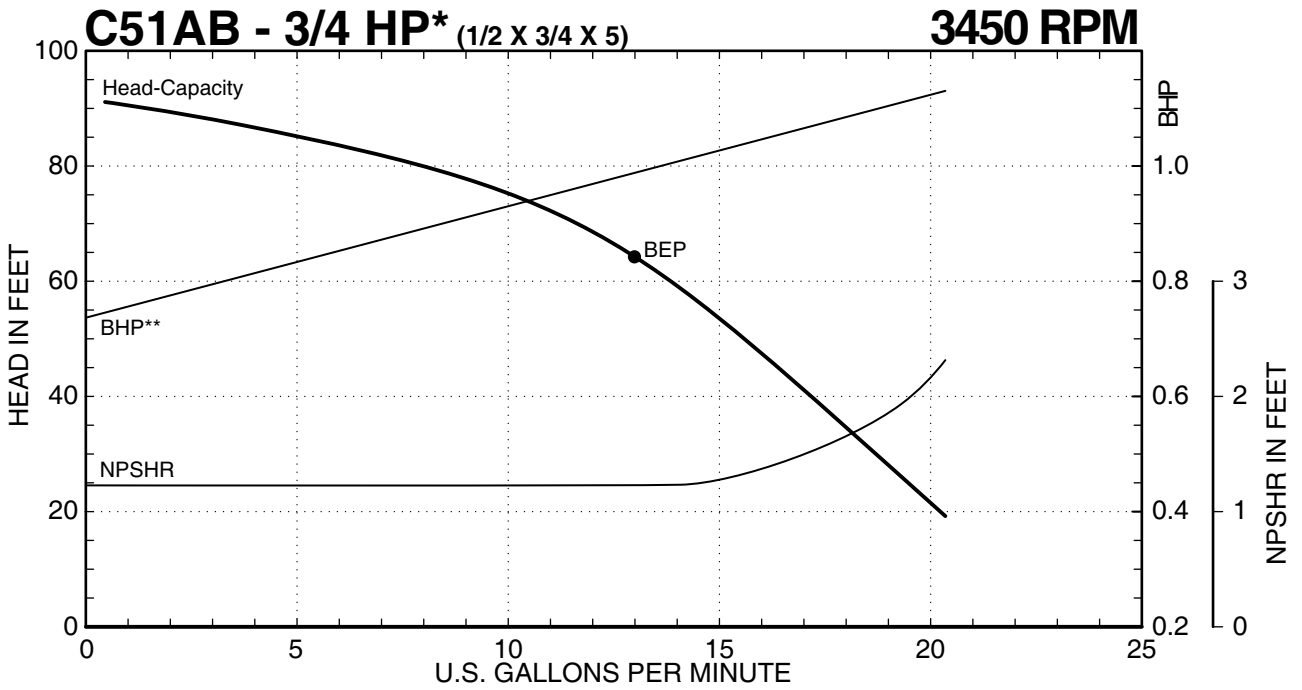

MTH PUMPS

401 West Main Street • Plano, IL 60545-1436
 Phone: 630-552-4115 • Fax: 630-552-3688
 Email: SALES@MTHPUMPS.COM
<http://WWW.MTHPUMPS.COM>

*High Service Factor Motor Horsepower Selections - See Standard Motor Guide and/or Motor Price Sheets for more information.
 **BHP data valid for 1.0 specific gravity fluids only.

C41 • C51 • C61 SERIES

Performance Curves

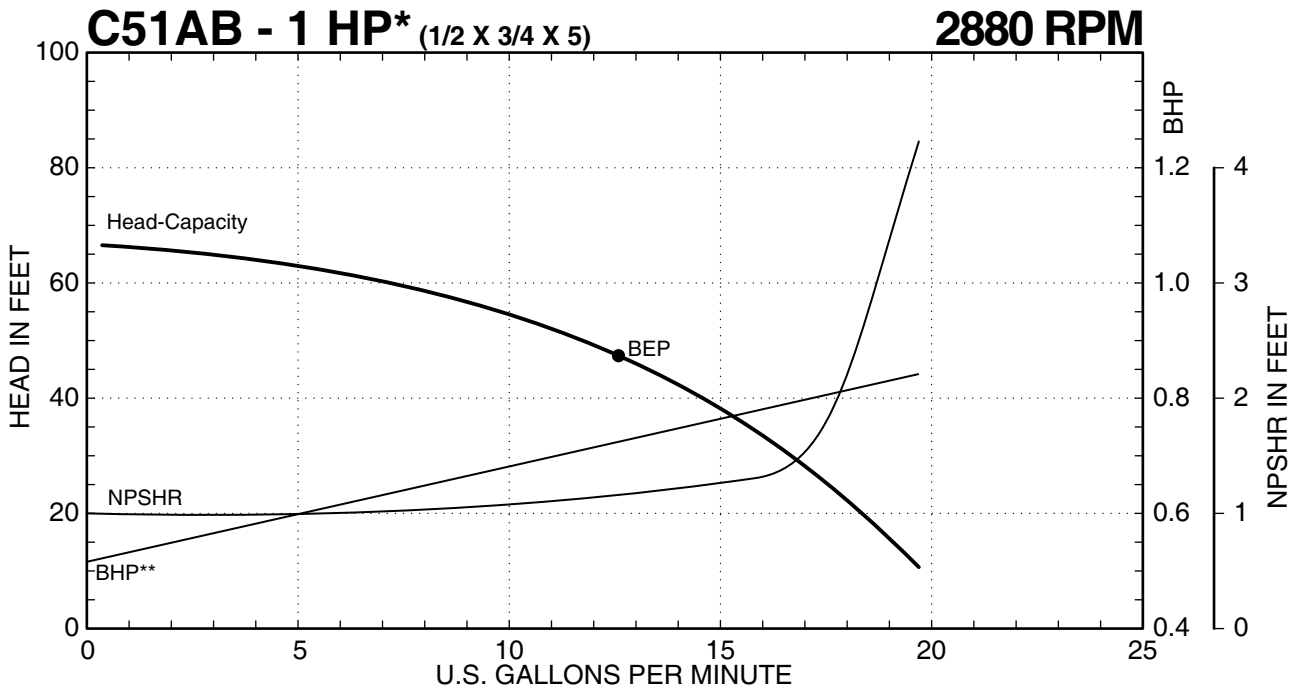
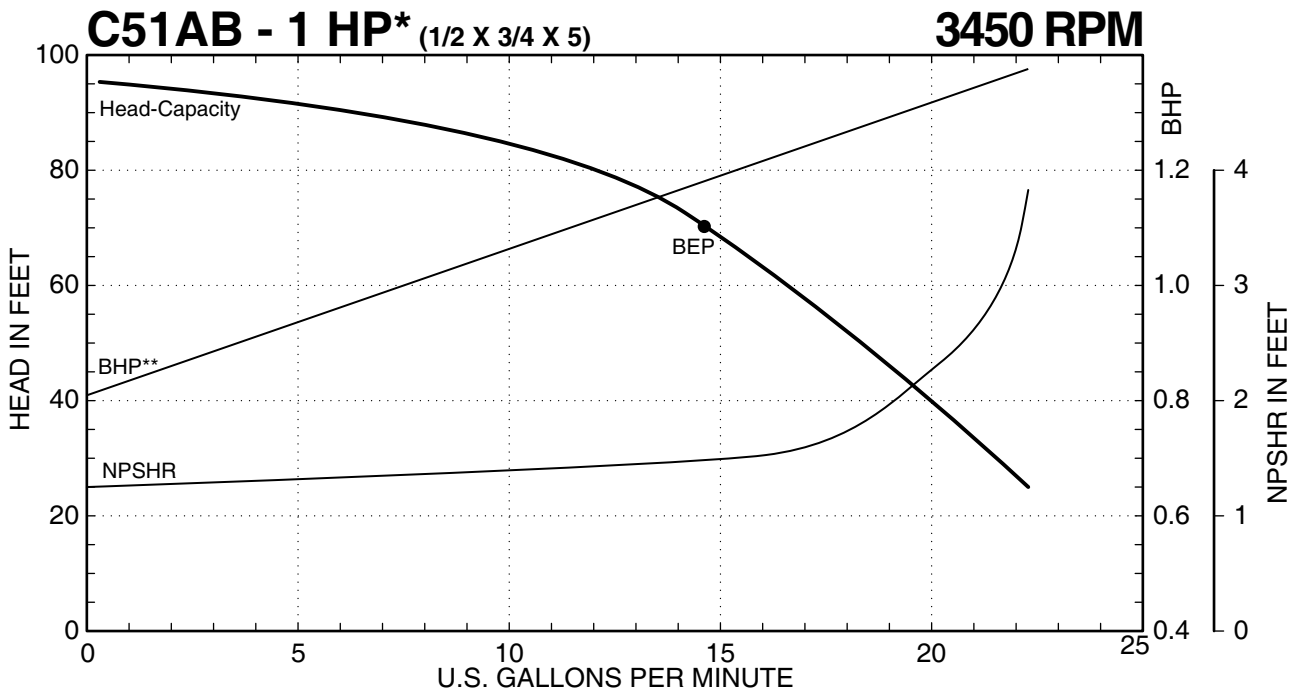

C51 SERIES PUMPS



MTH PUMPS

401 West Main Street • Plano, IL 60545-1436
 Phone: 630-552-4115 • Fax: 630-552-3688
 Email: SALES@MTHPUMPS.COM
<http://WWW.MTHPUMPS.COM>

*High Service Factor Motor Horsepower Selections - See Standard Motor Guide and/or Motor Price Sheets for more information.
 **BHP data valid for 1.0 specific gravity fluids only.

C41 • C51 • C61 SERIES

Performance Curves

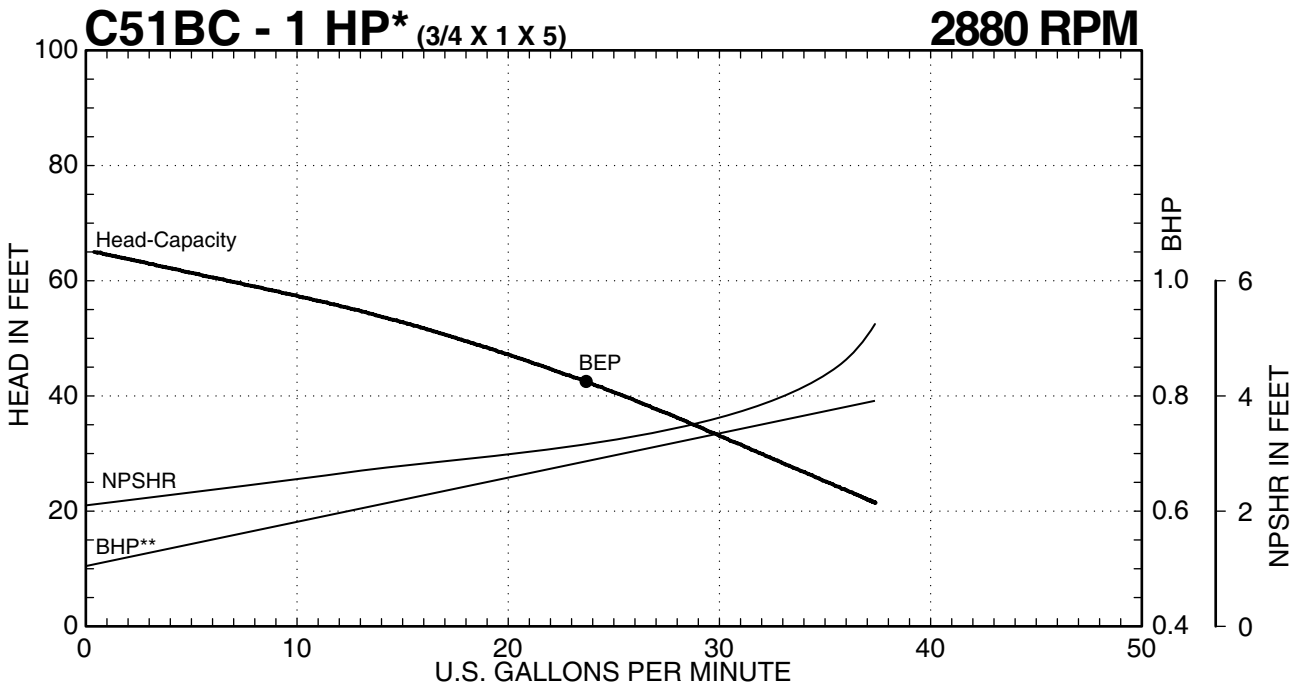
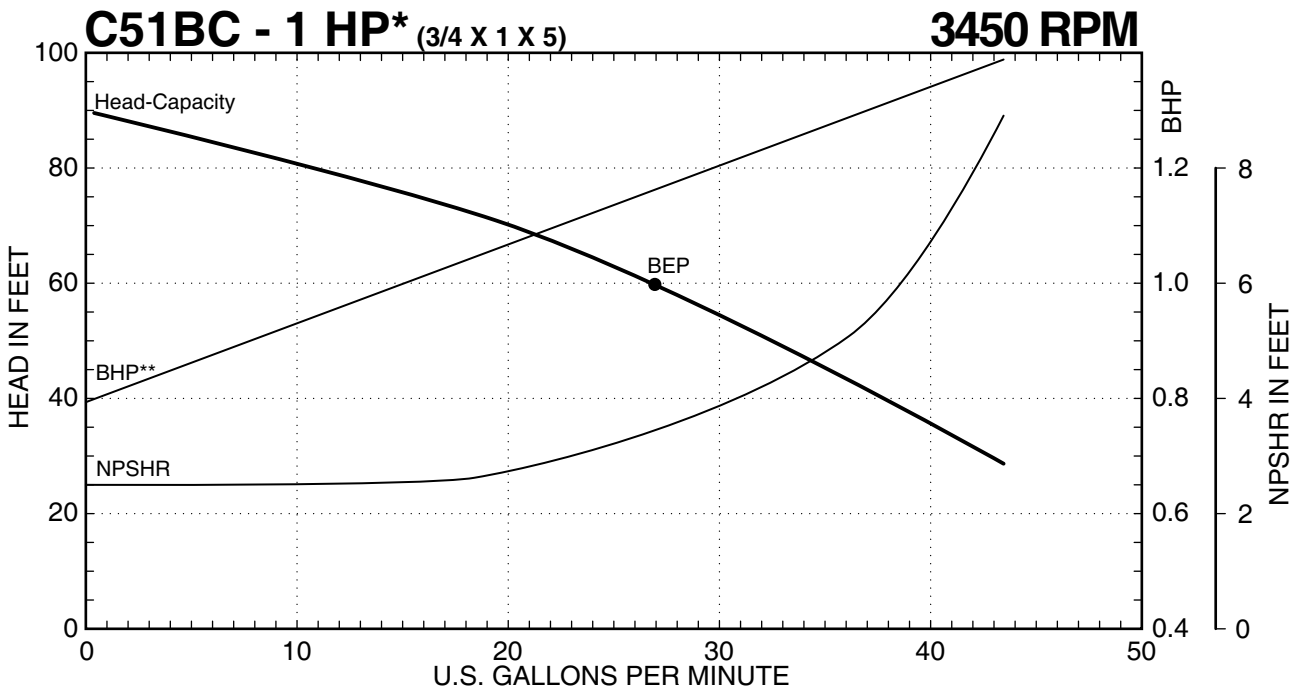

MTH PUMPS

401 West Main Street • Plano, IL 60545-1436
 Phone: 630-552-4115 • Fax: 630-552-3688
 Email: SALES@MTHPUMPS.COM
<http://WWW.MTHPUMPS.COM>

*High Service Factor Motor Horsepower Selections - See Standard Motor Guide and/or Motor Price Sheets for more information.
 **BHP data valid for 1.0 specific gravity fluids only.

C51 SERIES PUMPS

C41 • C51 • C61 SERIES

Performance Curves

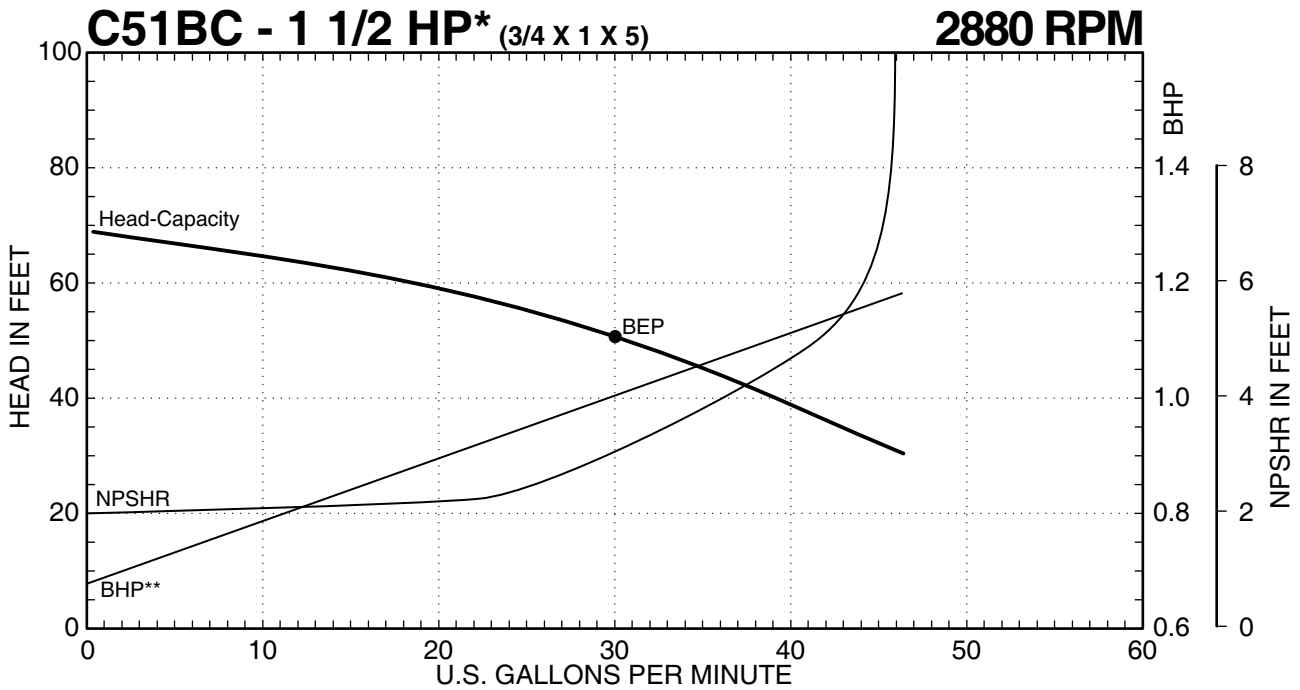
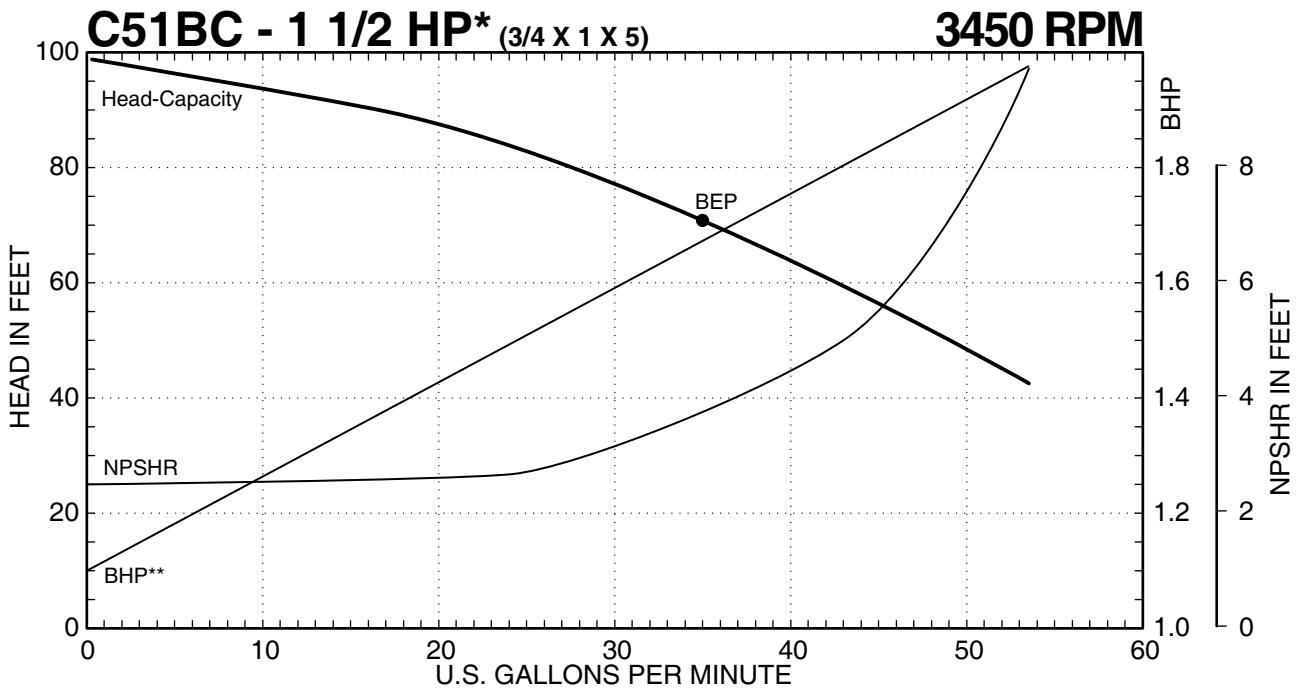

C51 SERIES PUMPS



MTH PUMPS

401 West Main Street • Plano, IL 60545-1436
 Phone: 630-552-4115 • Fax: 630-552-3688
 Email: SALES@MTHPUMPS.COM
<http://WWW.MTHPUMPS.COM>

*High Service Factor Motor Horsepower Selections - See Standard Motor Guide and/or Motor Price Sheets for more information.
 **BHP data valid for 1.0 specific gravity fluids only.

C41 • C51 • C61 SERIES

Performance Curves

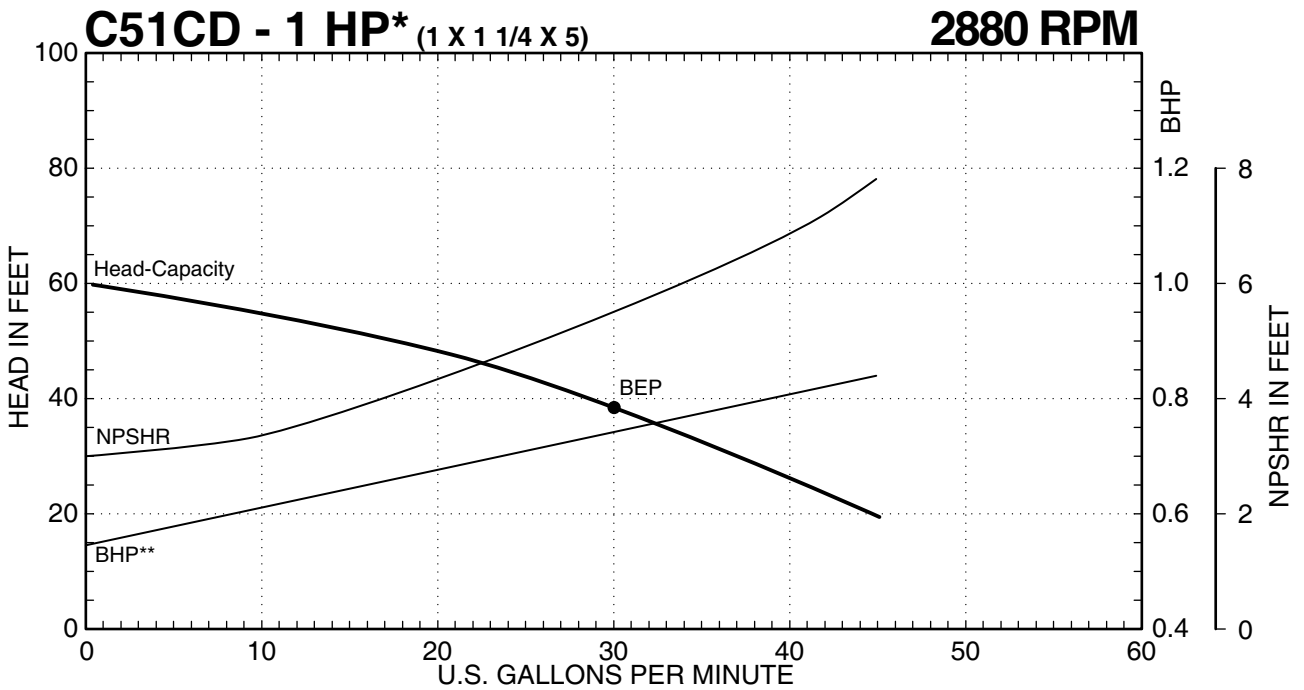
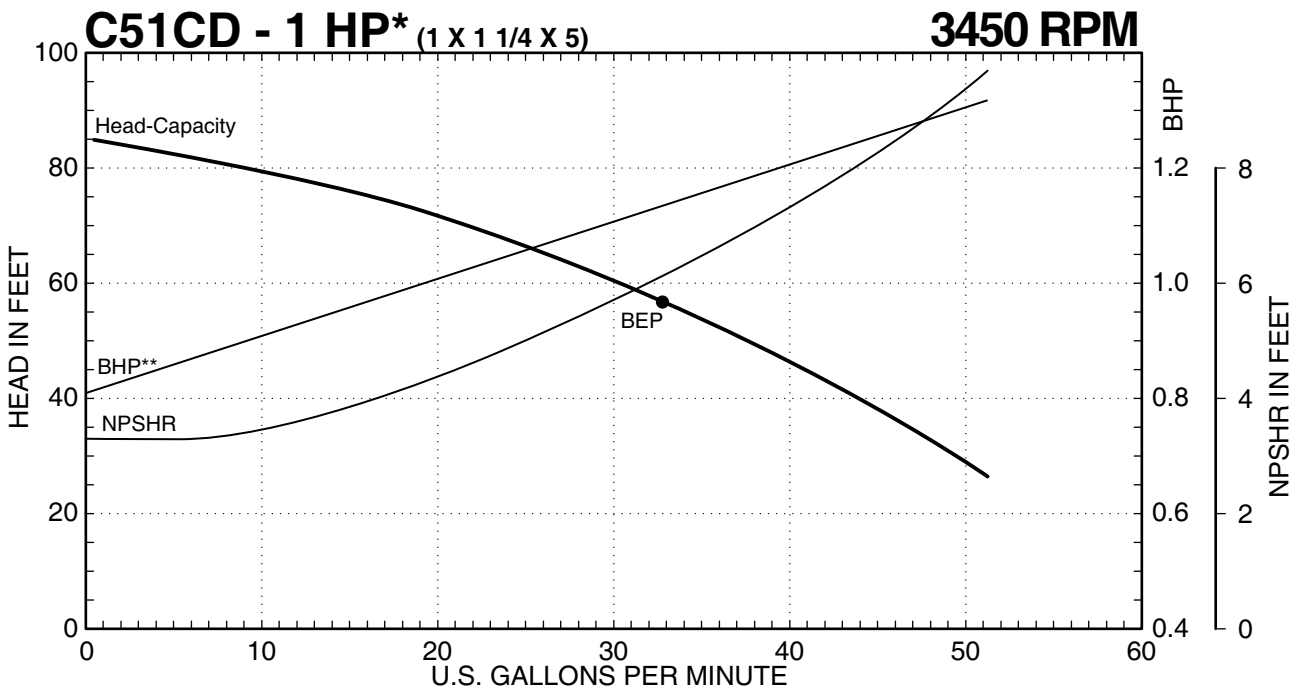

MTH PUMPS

401 West Main Street • Plano, IL 60545-1436
 Phone: 630-552-4115 • Fax: 630-552-3688
 Email: SALES@MTHPUMPS.COM
<http://WWW.MTHPUMPS.COM>

*High Service Factor Motor Horsepower Selections - See Standard Motor Guide and/or Motor Price Sheets for more information.
 **BHP data valid for 1.0 specific gravity fluids only.

C51 SERIES PUMPS

C41 • C51 • C61 SERIES

Performance Curves

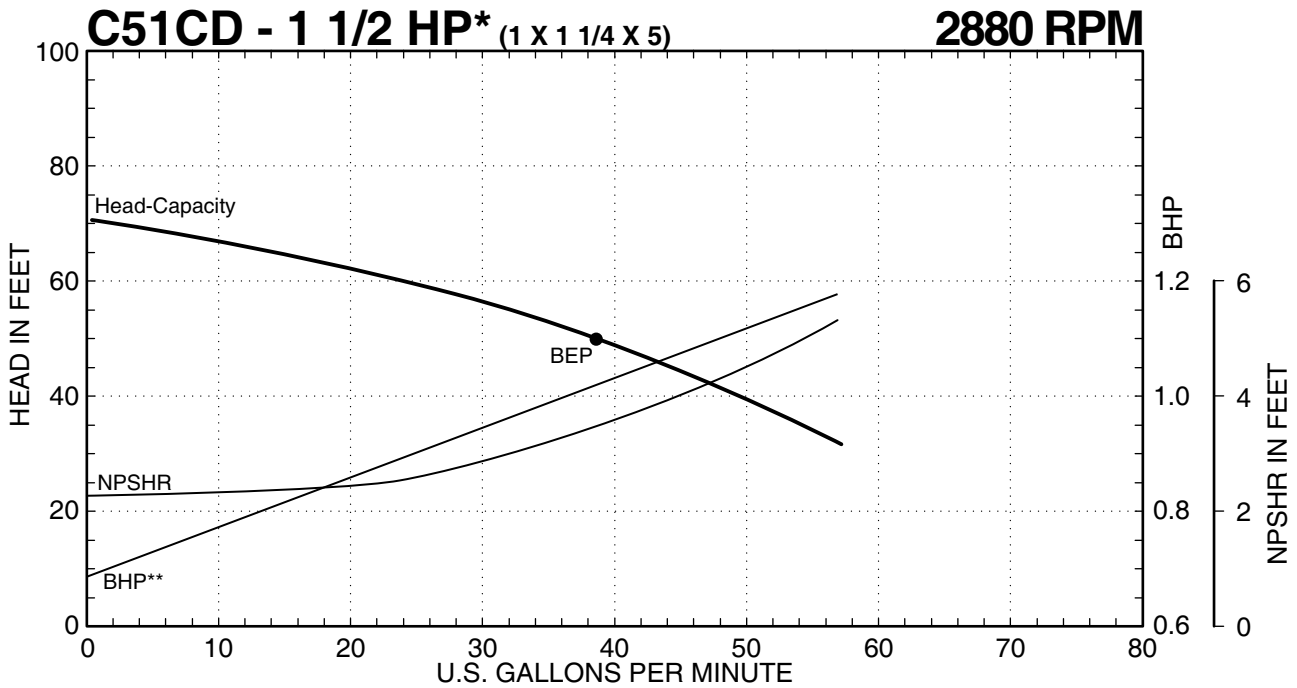
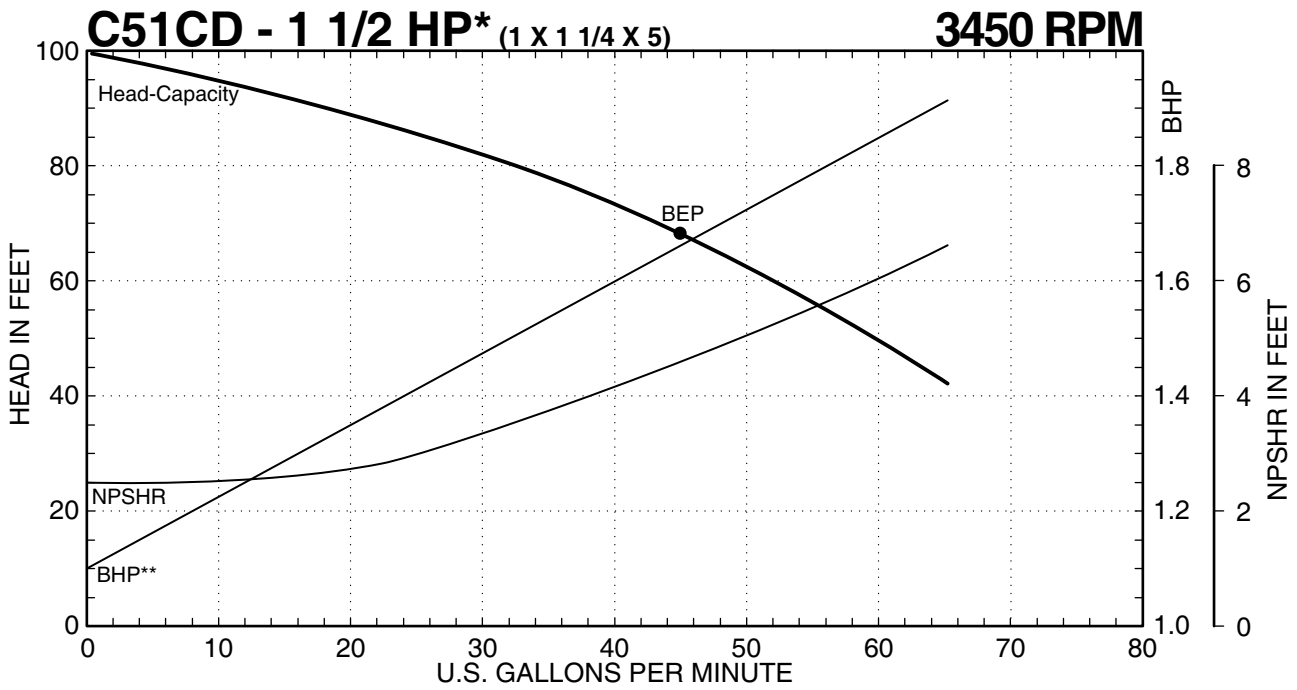

C51 SERIES PUMPS



MTH PUMPS

401 West Main Street • Plano, IL 60545-1436
 Phone: 630-552-4115 • Fax: 630-552-3688
 Email: SALES@MTHPUMPS.COM
 http://WWW.MTHPUMPS.COM

*High Service Factor Motor Horsepower Selections - See Standard Motor Guide and/or Motor Price Sheets for more information.
 **BHP data valid for 1.0 specific gravity fluids only.

C41 • C51 • C61 SERIES

Performance Curves

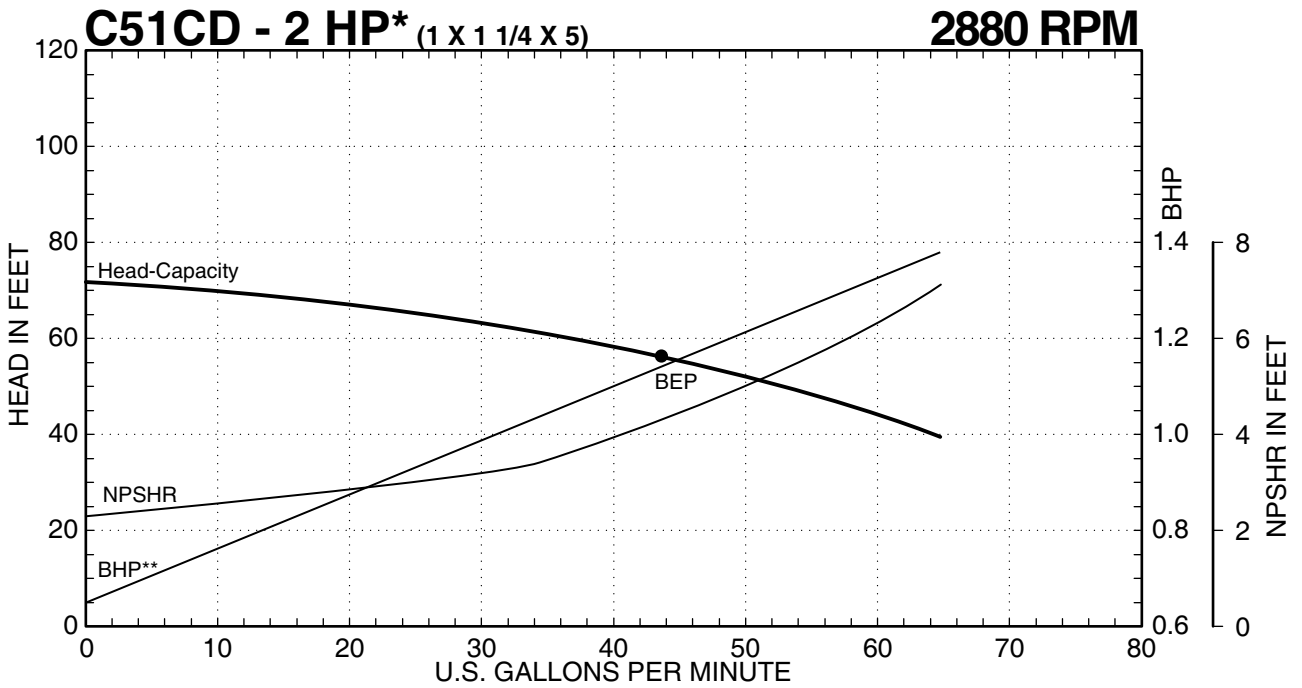
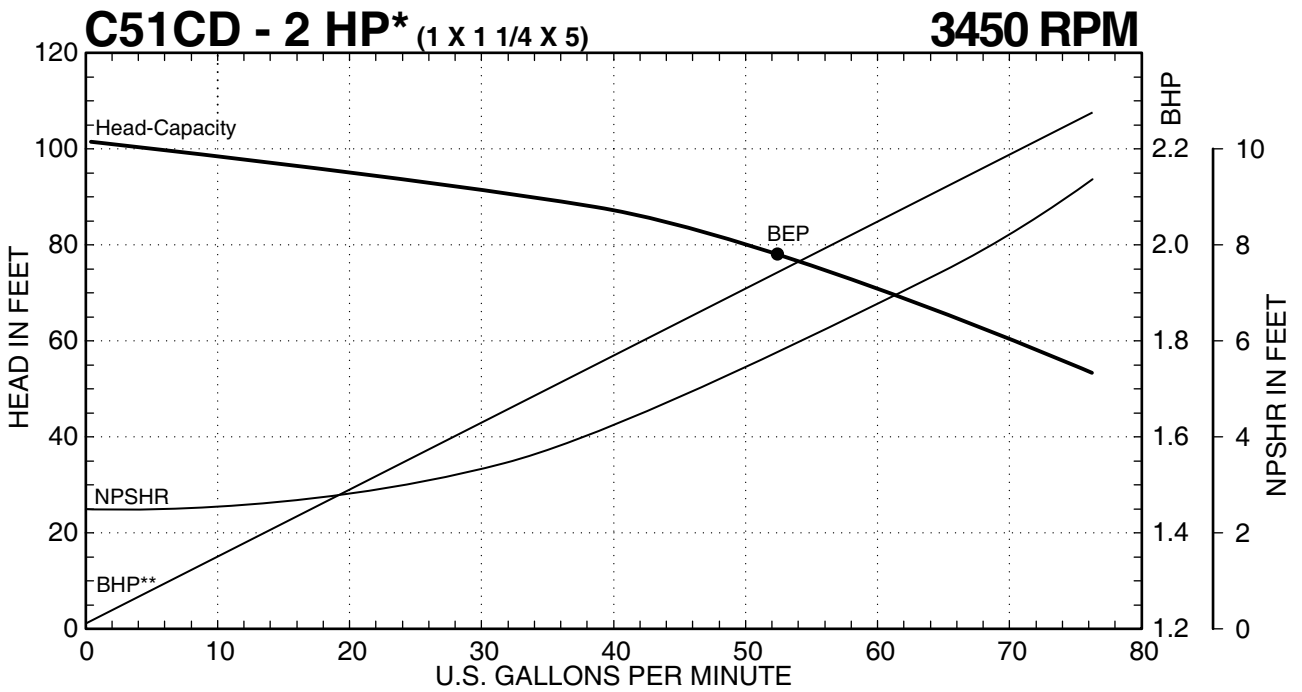

MTH PUMPS

401 West Main Street • Plano, IL 60545-1436
 Phone: 630-552-4115 • Fax: 630-552-3688
 Email: SALES@MTHPUMPS.COM
 http://WWW.MTHPUMPS.COM

*High Service Factor Motor Horsepower Selections - See Standard Motor Guide and/or Motor Price Sheets for more information.
 **BHP data valid for 1.0 specific gravity fluids only.

C51 SERIES PUMPS

C41 • C51 • C61 SERIES

Performance Curves

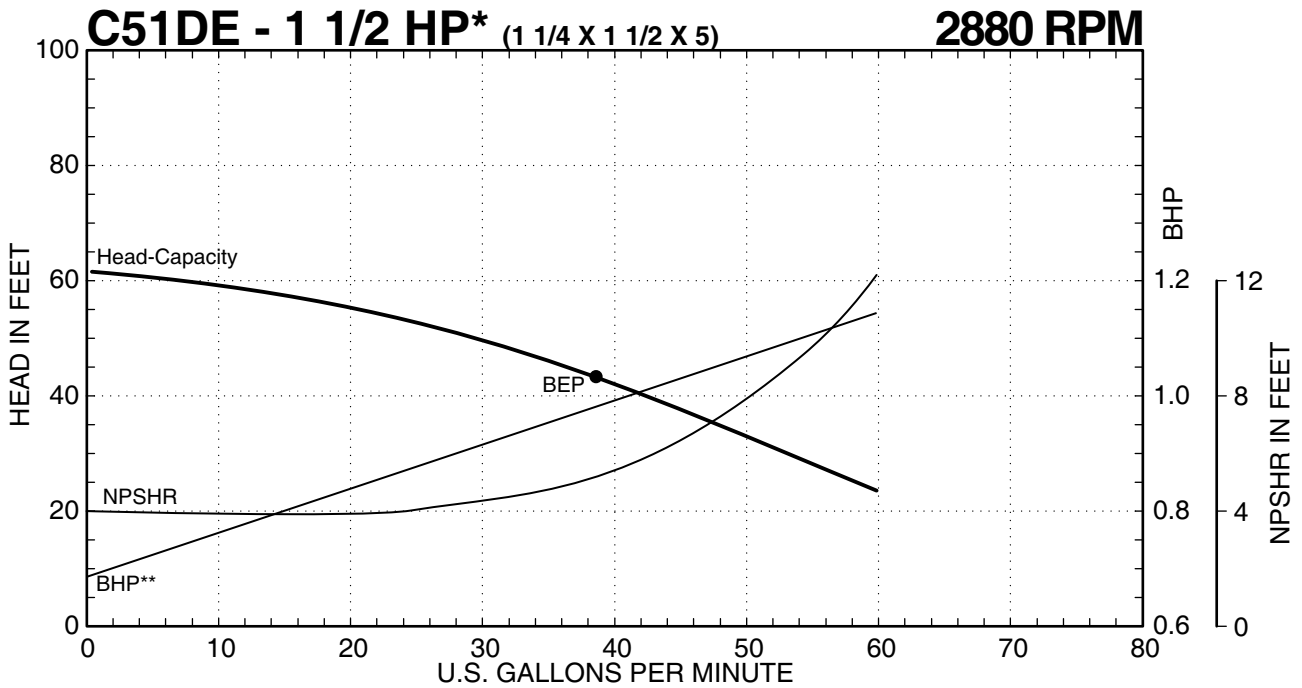
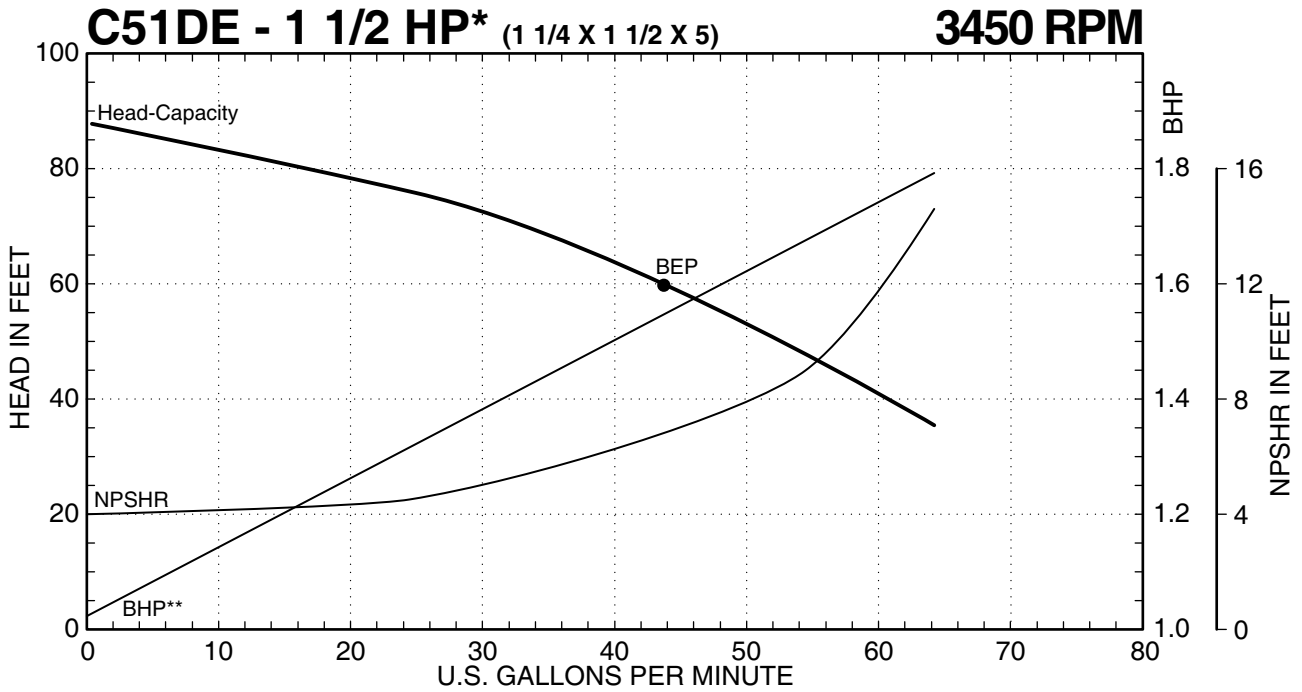

C51 SERIES PUMPS



MTH PUMPS

401 West Main Street • Plano, IL 60545-1436
 Phone: 630-552-4115 • Fax: 630-552-3688
 Email: SALES@MTHPUMPS.COM
<http://WWW.MTHPUMPS.COM>

*High Service Factor Motor Horsepower Selections - See Standard Motor Guide and/or Motor Price Sheets for more information.
 **BHP data valid for 1.0 specific gravity fluids only.

C41 • C51 • C61 SERIES

Performance Curves

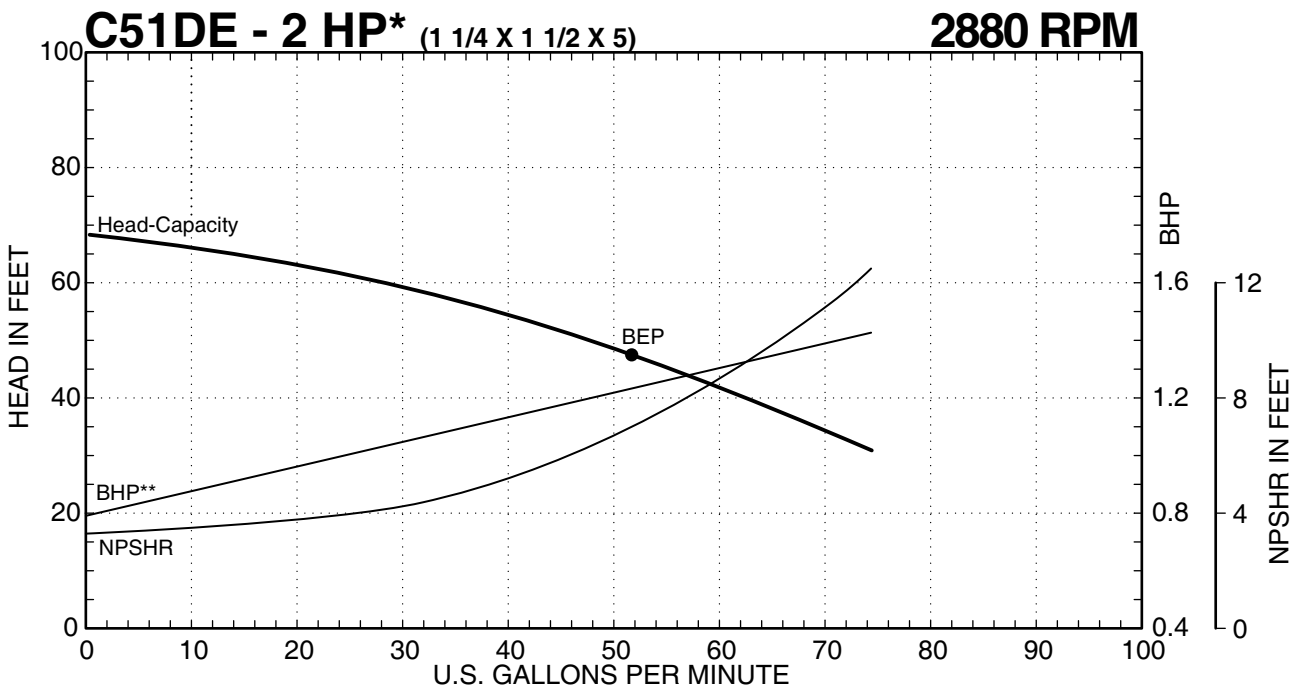
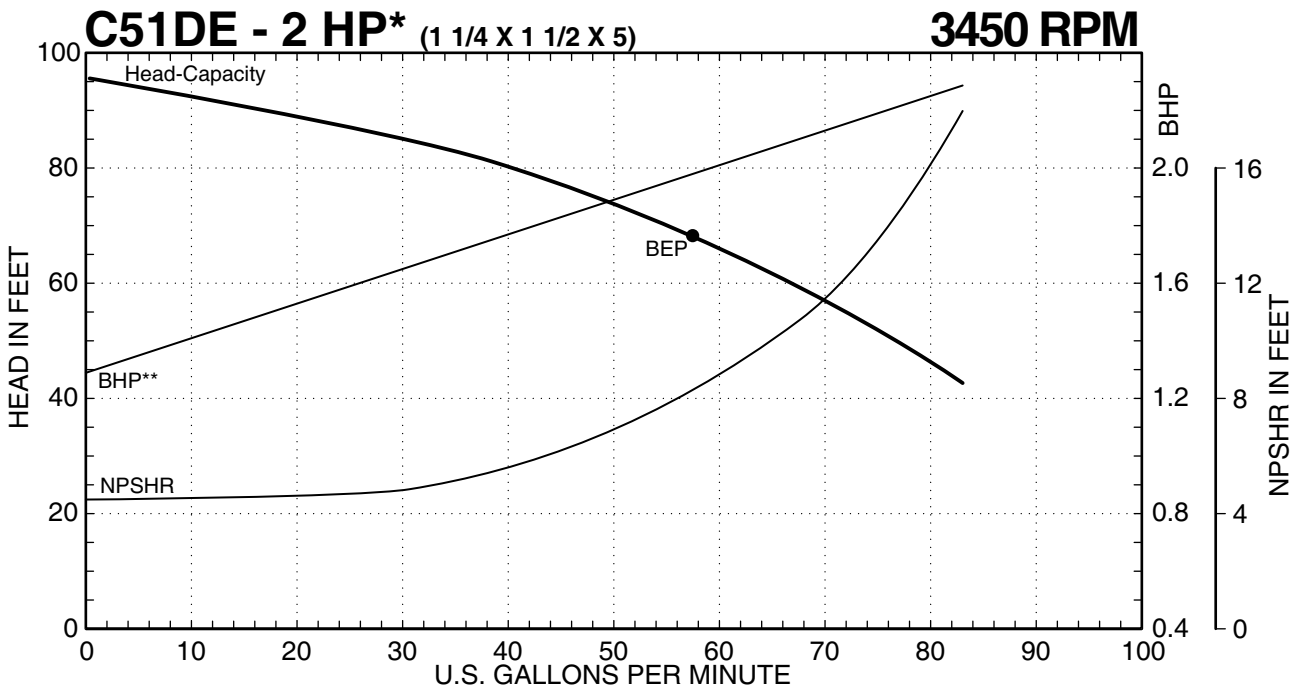

MTH PUMPS

401 West Main Street • Plano, IL 60545-1436
 Phone: 630-552-4115 • Fax: 630-552-3688
 Email: SALES@MTHPUMPS.COM
 http://WWW.MTHPUMPS.COM

*High Service Factor Motor Horsepower Selections - See Standard Motor Guide and/or Motor Price Sheets for more information.
 **BHP data valid for 1.0 specific gravity fluids only.

C51 SERIES PUMPS

C41 • C51 • C61 SERIES

C51 Dimensions

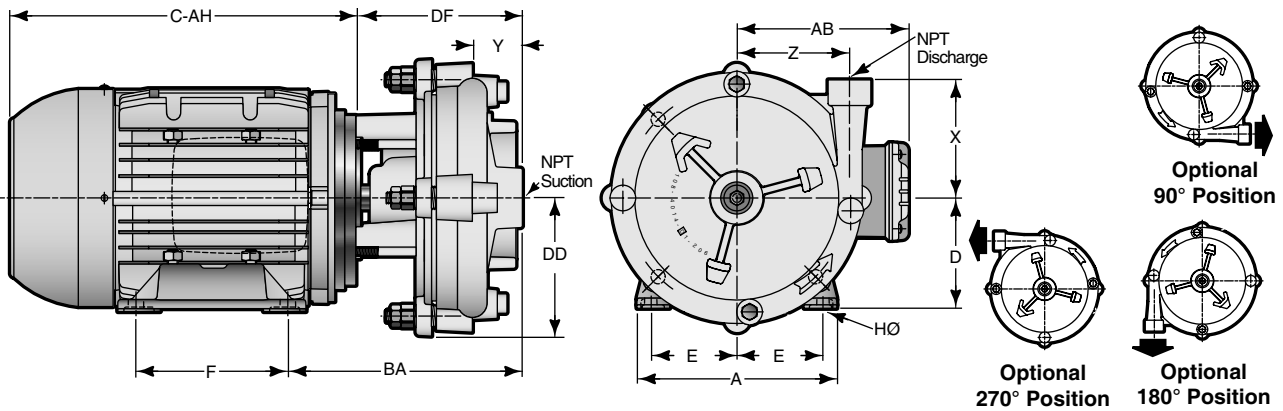

3 Phase TEFC Motors

Pump Size				71 Frame (1/3 HP - 1 HP)								80 Frame (1 1/2 HP - 2 HP)									
Model	Disch.	Suction	Imp. Ø	DD	DF	X	Y	Z	A	AB	D	E	F	BA	A	AB	D	E	F	BA	
C51AB	1/2	3/4	5	3 1/2	4 3/8	3 1/16	1 5/16	2 3/4	5	5	2 13/16	2 3/16	3 9/16	6 7/16	---	---	---	---	---	---	---
C51BC	3/4	1	5	3 1/2	4 7/16	3 1/16	1 5/16	2 13/16	5	5	2 13/16	2 3/16	3 9/16	6 7/16	5 1/8	5 1/8	3 1/8	2 7/16	3 15/16	6 9/16	
C51CD	1	1 1/4	5	3 5/8	4 9/16	3 3/16	1 1/2	3	5	5	2 13/16	2 3/16	3 9/16	6 9/16	5 1/8	5 1/8	3 1/8	2 7/16	3 15/16	6 3/4	
C51DE	1 1/4	1 1/2	5	3 11/16	4 15/16	3 3/4	1 7/8	3 1/16	---	---	---	---	---	---	5 1/8	5 1/8	3 1/8	2 7/16	3 15/16	7 1/8	

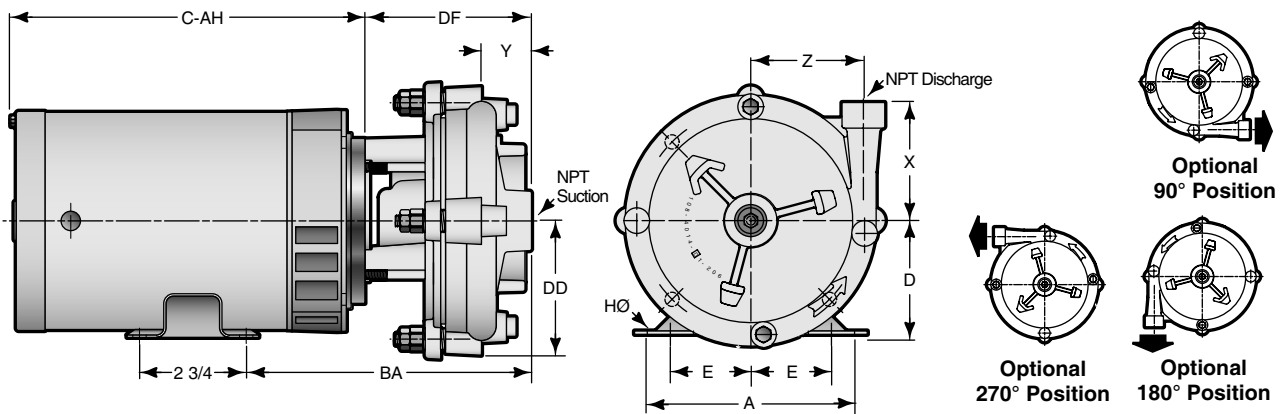

Single Phase ODP Motors

Pump Size				48 Frame (1/3 - 1 HP)								56 Frame (1 1/2 - 2 HP)			
Model	Disch.	Suction	Imp. Ø	DD	DF	X	Y	Z	A	D	E	H	BA	D	AG
C51AB	1/2	3/4	5	3 1/2	4 3/8	3 1/16	1 5/16	2 3/4	6 1/8	3	2 1/8	5/16-18	7 3/16	---	---
C51BC	3/4	1	5	3 1/2	4 7/16	3 1/16	1 5/16	2 13/16	6 1/8	3	2 1/8	5/16-18	7 3/4	---	---
C51CD	1	1 1/4	5	3 5/8	4 9/16	3 3/16	1 1/2	3	6 1/8	3	2 1/8	5/16-18	7 9/16	3 1/2	10 15/16
C51DE	1 1/4	1 1/2	5	3 11/16	4 15/16	3 3/4	1 7/8	3 1/16	6 1/8	3	2 1/8	5/16-18	7 13/16	3 1/2	10 15/16

C51 SERIES PUMPS

NOTES: All dimensions in inches. May vary ± 1/4 inches.
Not for construction purposes unless certified.

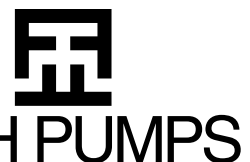

401 West Main Street • Plano, IL 60545-1436
Phone: 630-552-4115 • Fax: 630-552-3688
Email: SALES@MTHPUMPS.COM
http://WWW.MTHPUMPS.COM

C41 • C51 • C61 SERIES

Composite Curve

C61 SERIES PUMPS

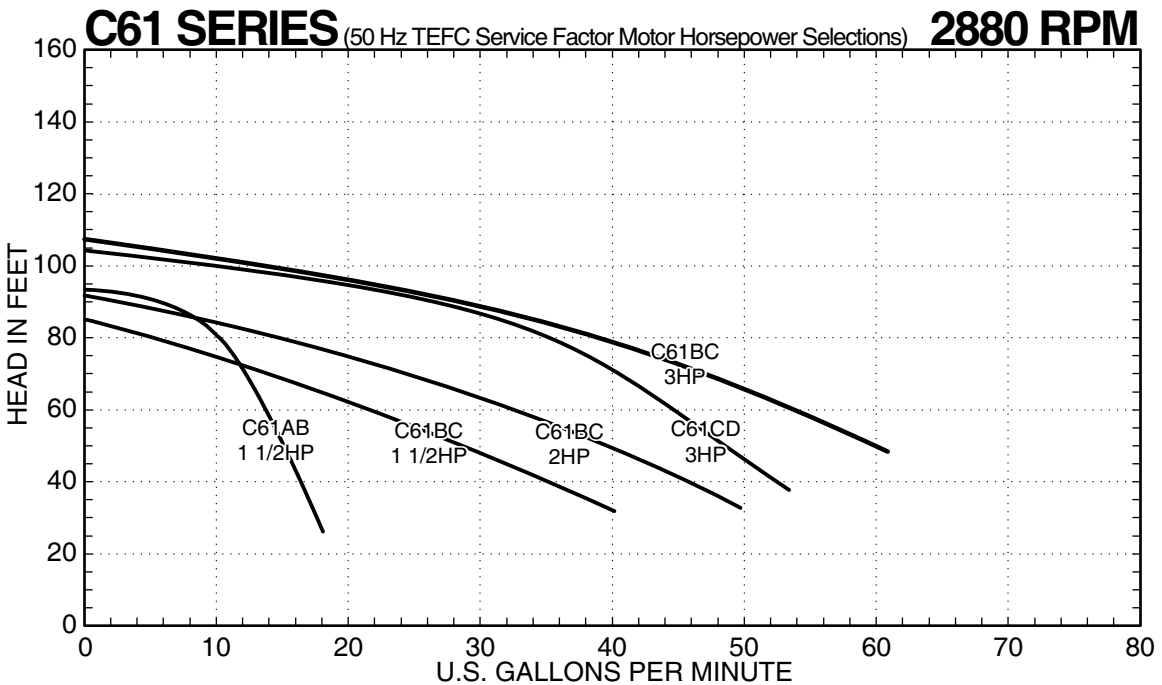
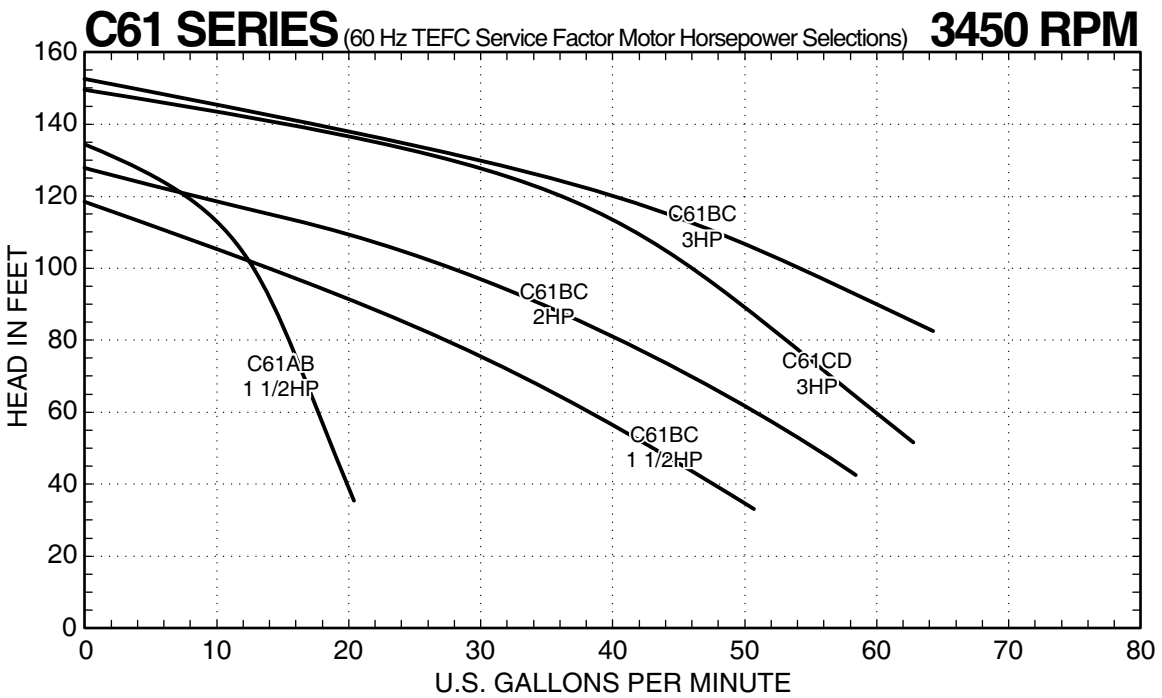

MTH PUMPS

401 West Main Street • Plano, IL 60545-1436
 Phone: 630-552-4115 • Fax: 630-552-3688
 Email: SALES@MTHPUMPS.COM
<http://WWW.MTHPUMPS.COM>

C41 • C51 • C61 SERIES

Performance Curves

C61 SERIES PUMPS

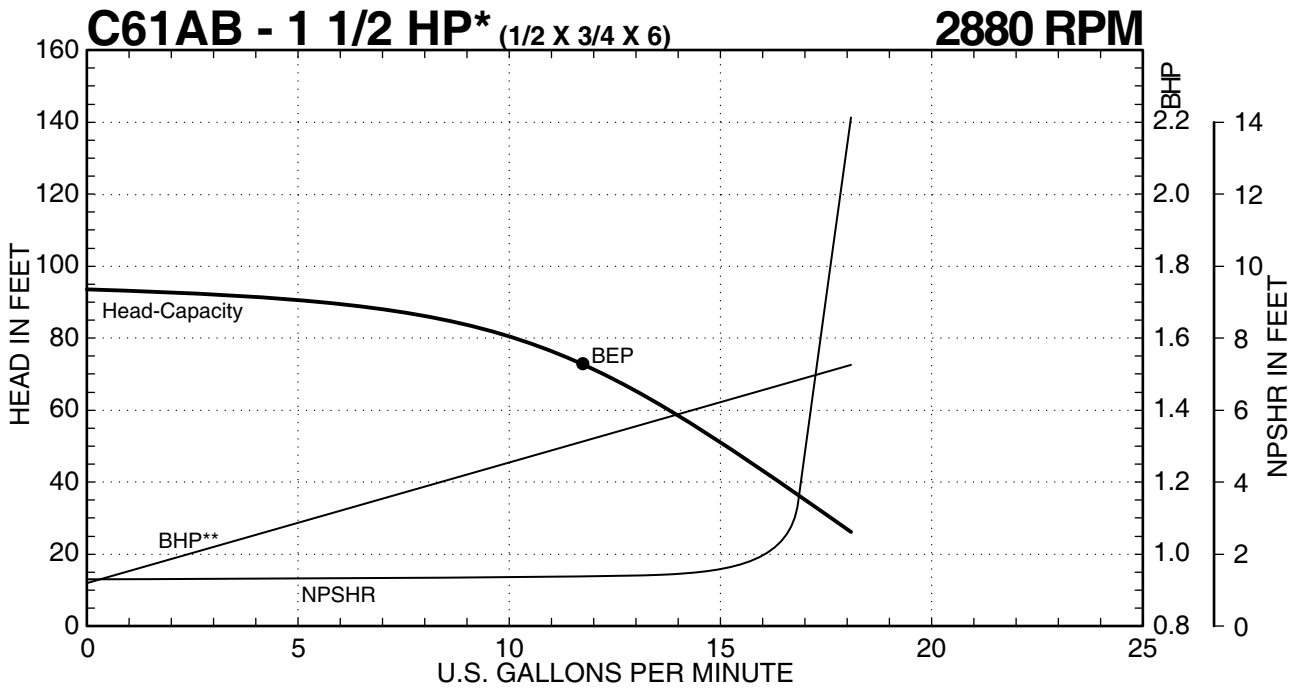
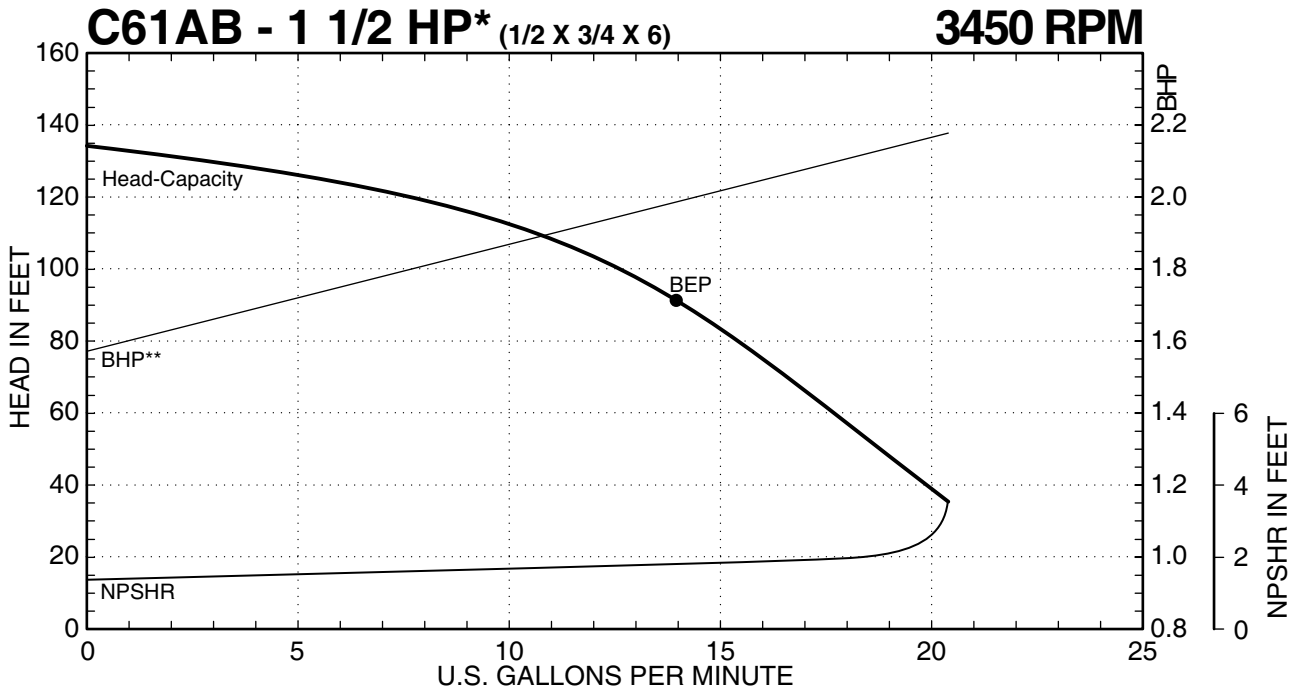

MTH PUMPS

401 West Main Street • Plano, IL 60545-1436
 Phone: 630-552-4115 • Fax: 630-552-3688
 Email: SALES@MTHPUMPS.COM
 http://WWW.MTHPUMPS.COM

*High Service Factor Motor Horsepower Selections - See Standard Motor Guide and/or Motor Price Sheets for more information.
 **BHP data valid for 1.0 specific gravity fluids only.

C41 • C51 • C61 SERIES

Performance Curves

C61 SERIES PUMPS

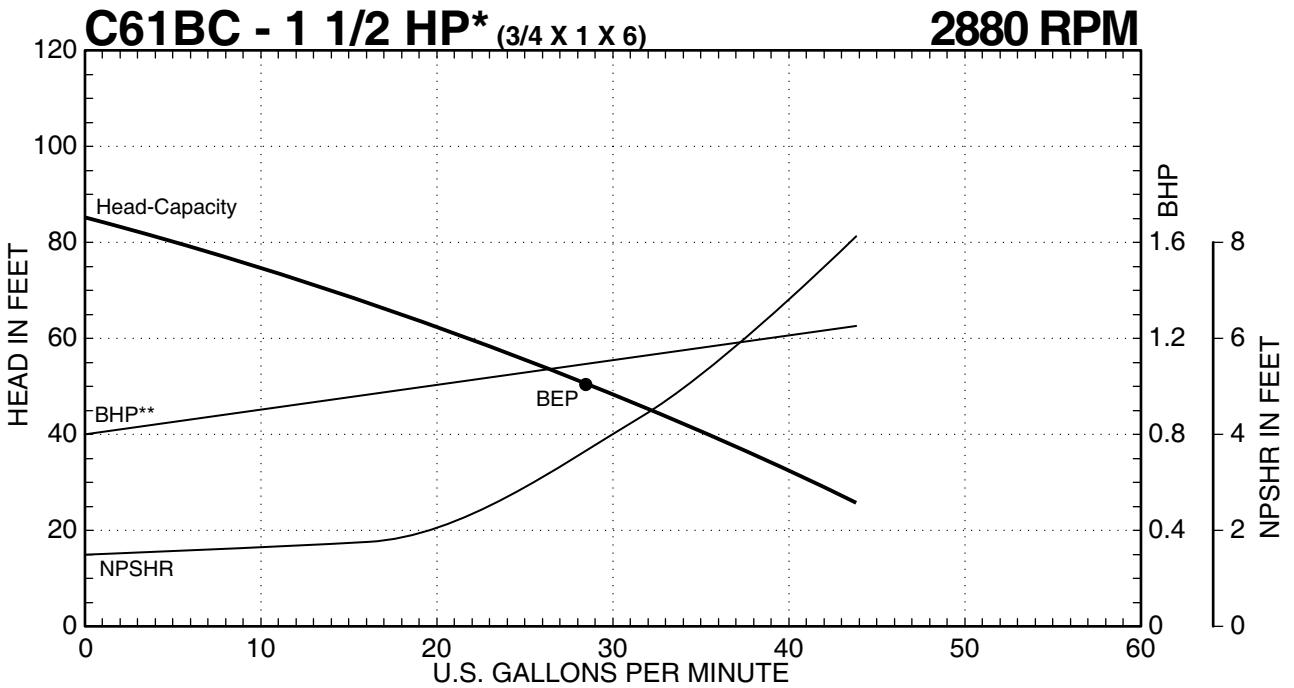
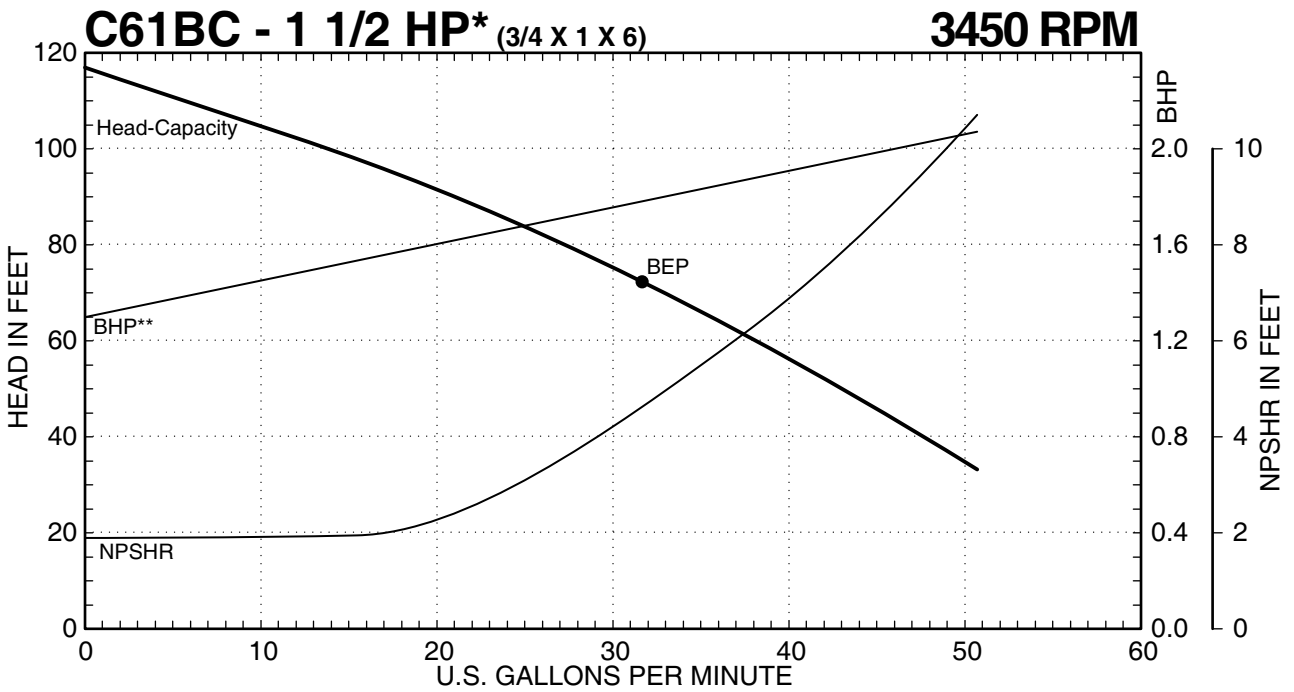

MTH PUMPS

401 West Main Street • Plano, IL 60545-1436
 Phone: 630-552-4115 • Fax: 630-552-3688
 Email: SALES@MTHPUMPS.COM
 http://WWW.MTHPUMPS.COM

*High Service Factor Motor Horsepower Selections - See Standard Motor Guide and/or Motor Price Sheets for more information.
 **BHP data valid for 1.0 specific gravity fluids only.

C41 • C51 • C61 SERIES

Performance Curves

C61 SERIES PUMPS

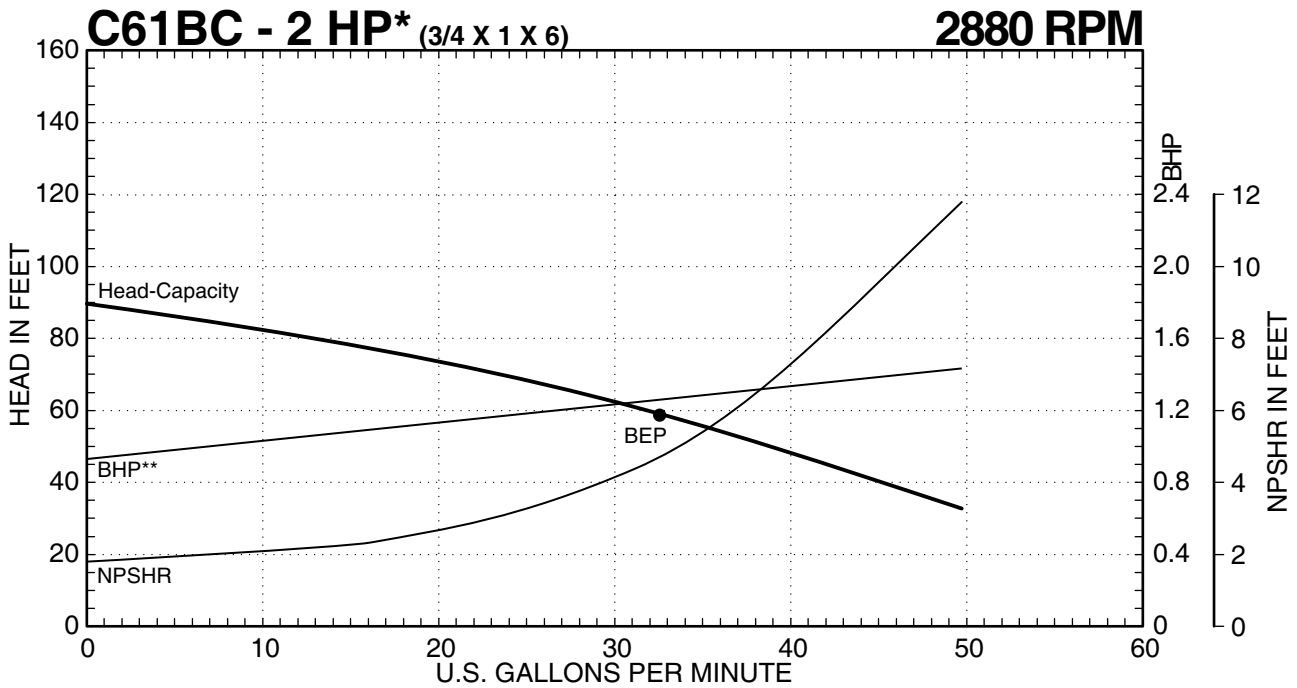
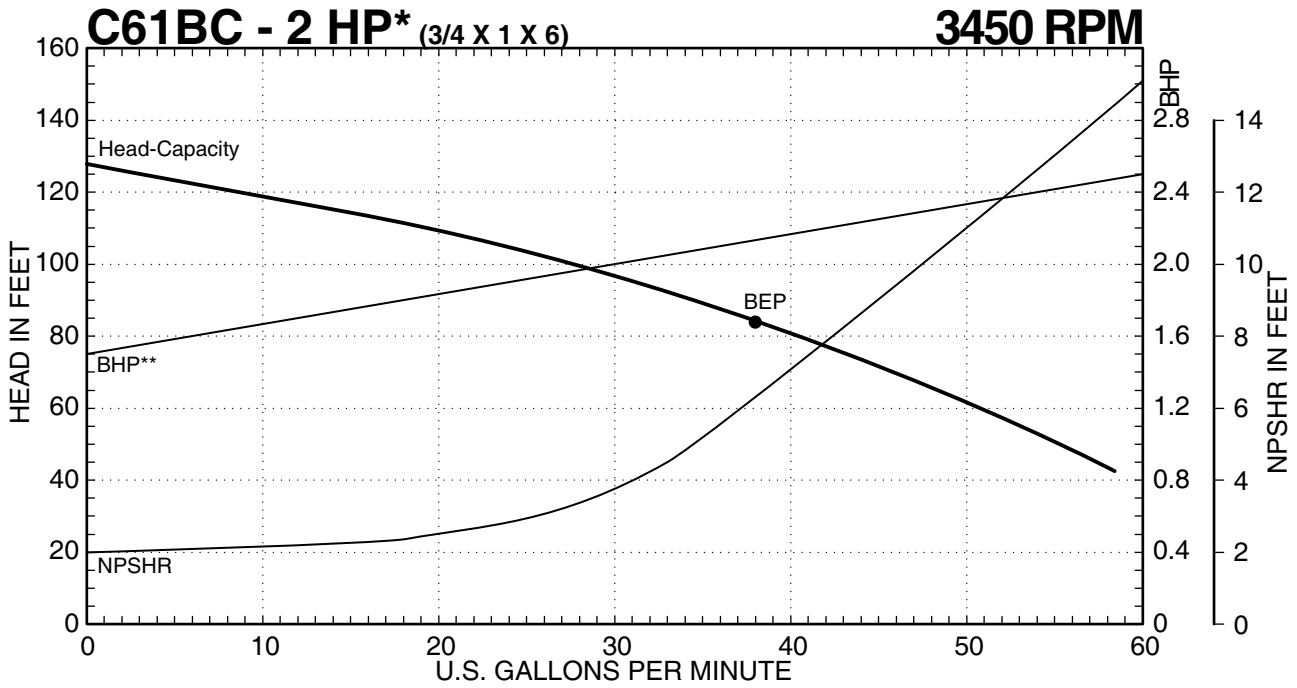

MTH PUMPS

401 West Main Street • Plano, IL 60545-1436
 Phone: 630-552-4115 • Fax: 630-552-3688
 Email: SALES@MTHPUMPS.COM
<http://WWW.MTHPUMPS.COM>

*High Service Factor Motor Horsepower Selections - See Standard Motor Guide and/or Motor Price Sheets for more information.
 **BHP data valid for 1.0 specific gravity fluids only.

C41 • C51 • C61 SERIES

Performance Curves

C61 SERIES PUMPS

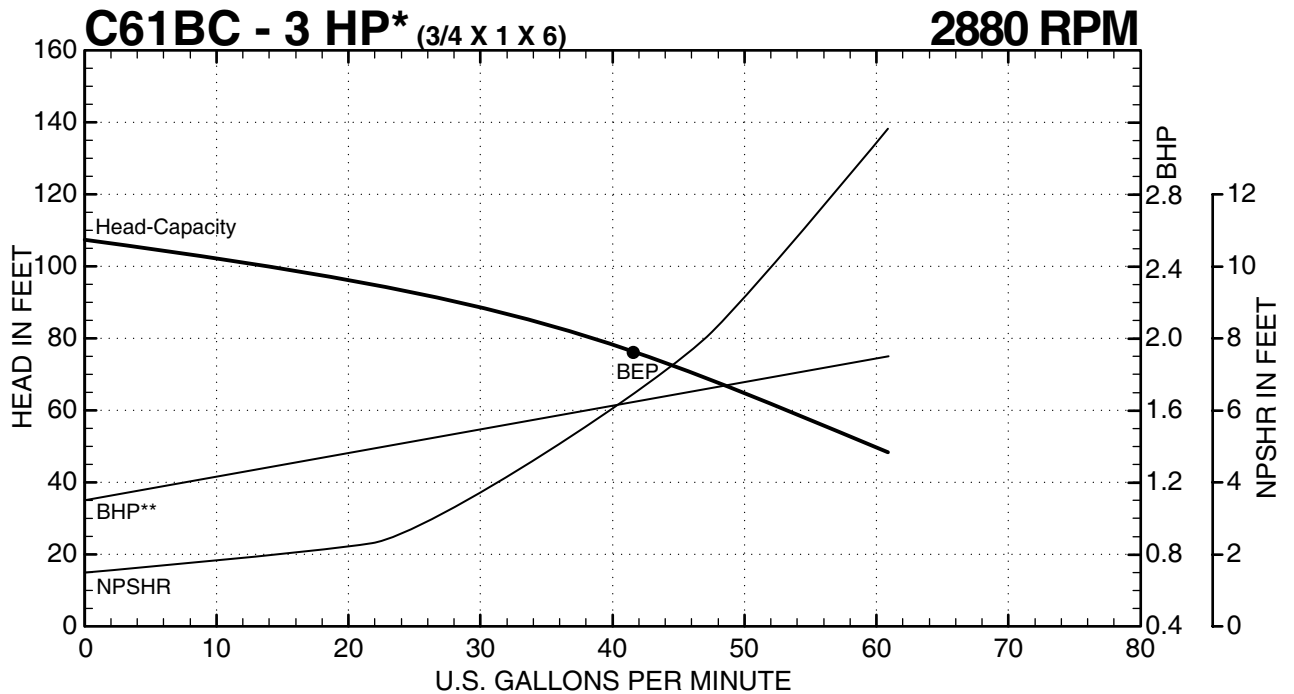
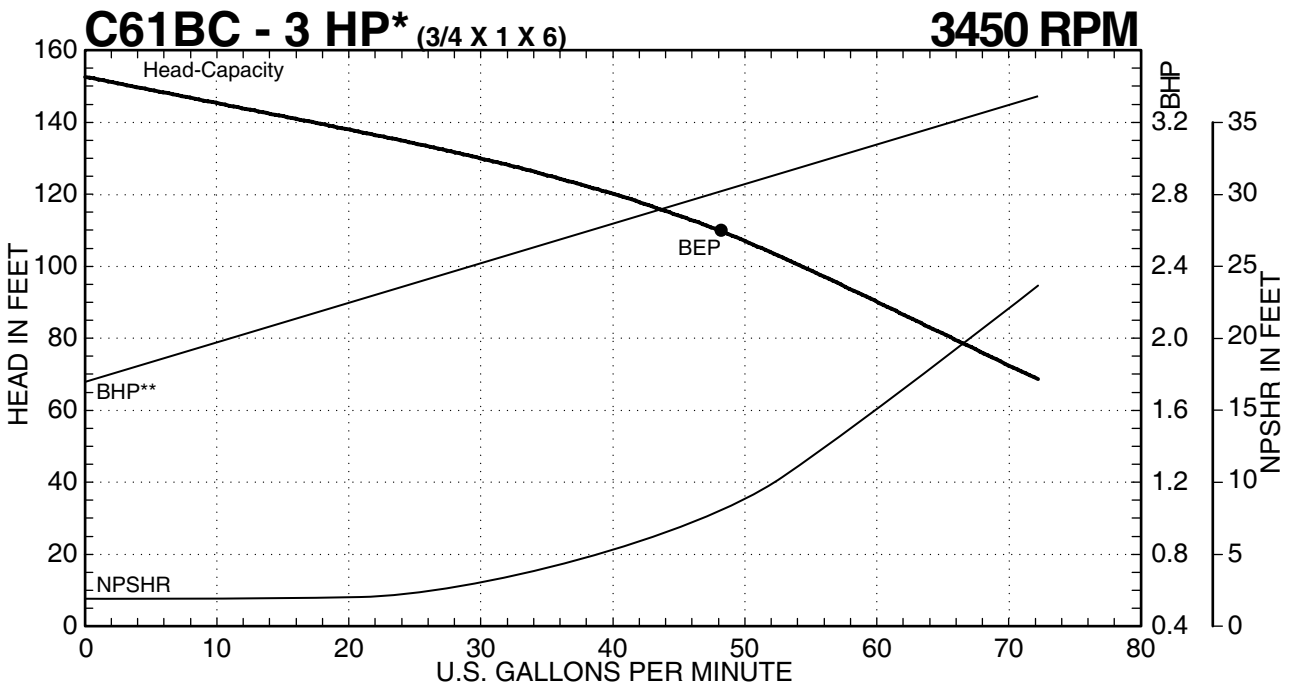

MTH PUMPS

401 West Main Street • Plano, IL 60545-1436
 Phone: 630-552-4115 • Fax: 630-552-3688
 Email: SALES@MTHPUMPS.COM
 http://WWW.MTHPUMPS.COM

*High Service Factor Motor Horsepower Selections - See Standard Motor Guide and/or Motor Price Sheets for more information.
 **BHP data valid for 1.0 specific gravity fluids only.

C41 • C51 • C61 SERIES

Performance Curves

C61 SERIES PUMPS

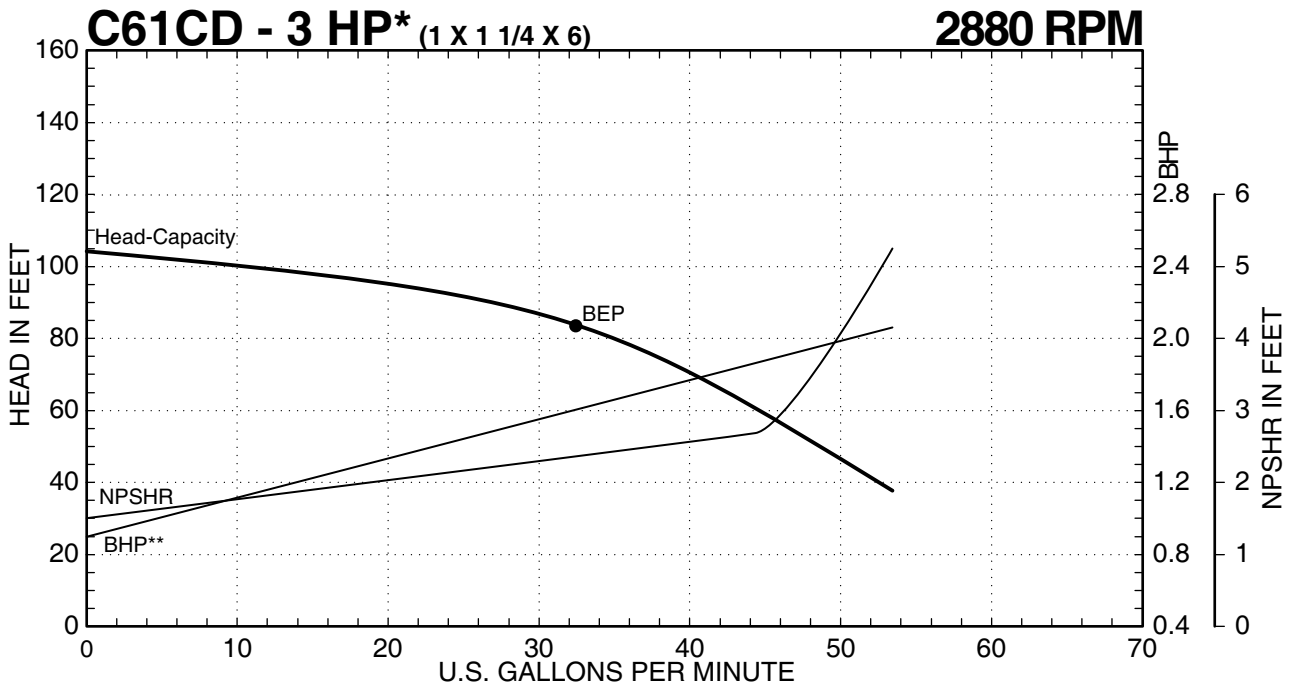
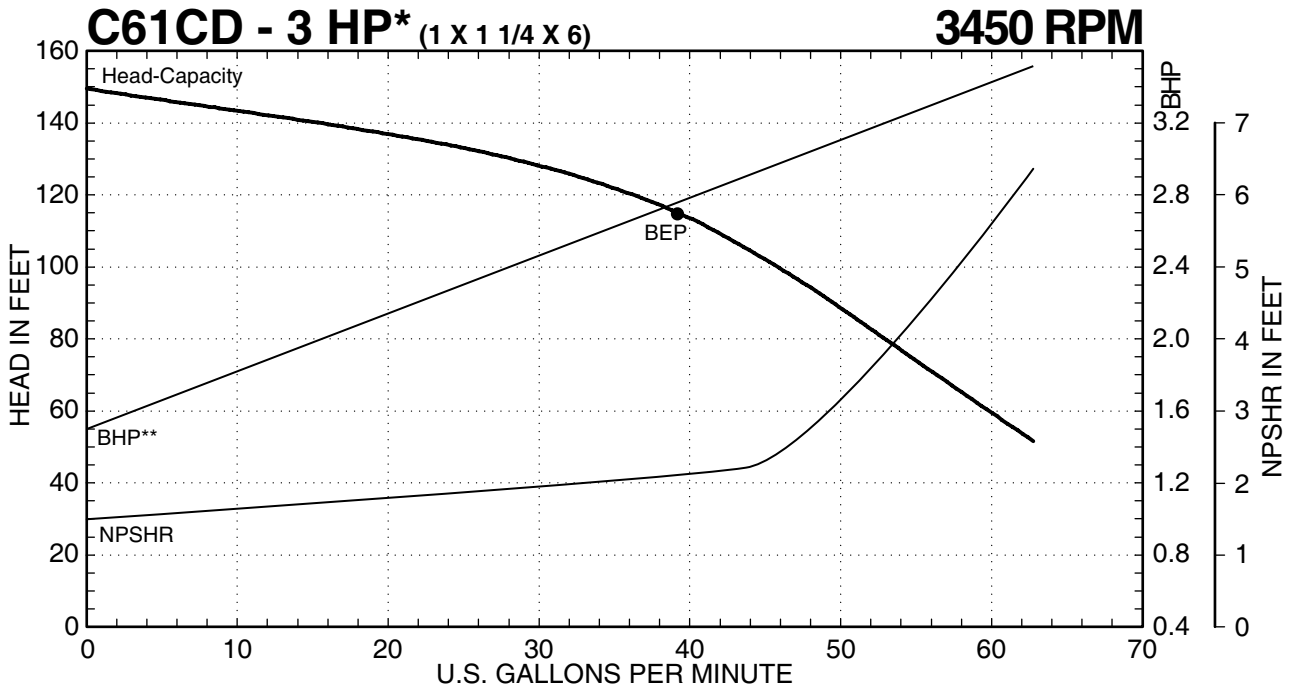

MTH PUMPS

401 West Main Street • Plano, IL 60545-1436
 Phone: 630-552-4115 • Fax: 630-552-3688
 Email: SALES@MTHPUMPS.COM
<http://WWW.MTHPUMPS.COM>

*High Service Factor Motor Horsepower Selections - See Standard Motor Guide and/or Motor Price Sheets for more information.
 **BHP data valid for 1.0 specific gravity fluids only.

C41 • C51 • C61 SERIES

C61 Dimensions

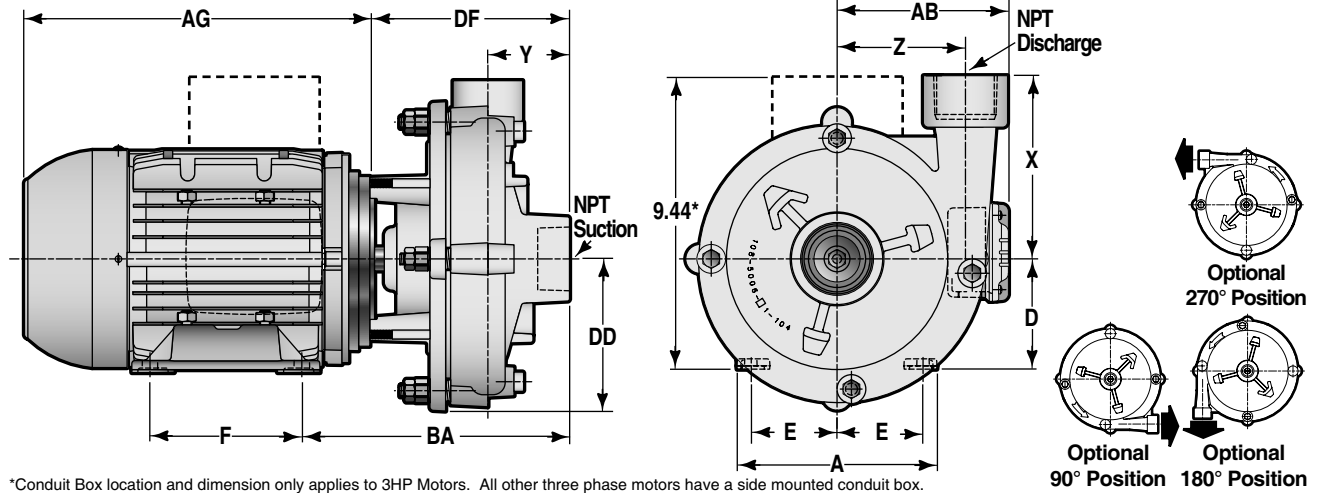

*Conduit Box location and dimension only applies to 3HP Motors. All other three phase motors have a side mounted conduit box.

Pump Size				3 Phase TEFC Motors												
Model	Disch.	Suction	Imp. Ø	DD	DF	X	Y	Z	Frame	A	AB	D	E	F	BA	AG
C61AB	1/2	3/4	6	3 15/16	4 5/8	3 7/16	1 1/2	3 5/16	80 (1 1/2HP - 2HP)	6 1/8	5 1/8	3 1/8	2 1/2	3 15/16	6 13/16	9 7/16
C61BC	3/4	1	6	3 15/16	4 7/16	3 15/16	1 5/16	3 1/4		6 1/8	5 1/8	3 1/8	2 1/2	3 15/16	6 13/16	9 7/16
C61CD	1	1 1/4	6	4 1/16	5 3/16	4 5/8	2 1/8	3 3/16		90 Frame (3HP)	6 11/16	5 7/8	3 9/16	2 3/4	4 15/16	7 3/4

All units in inches

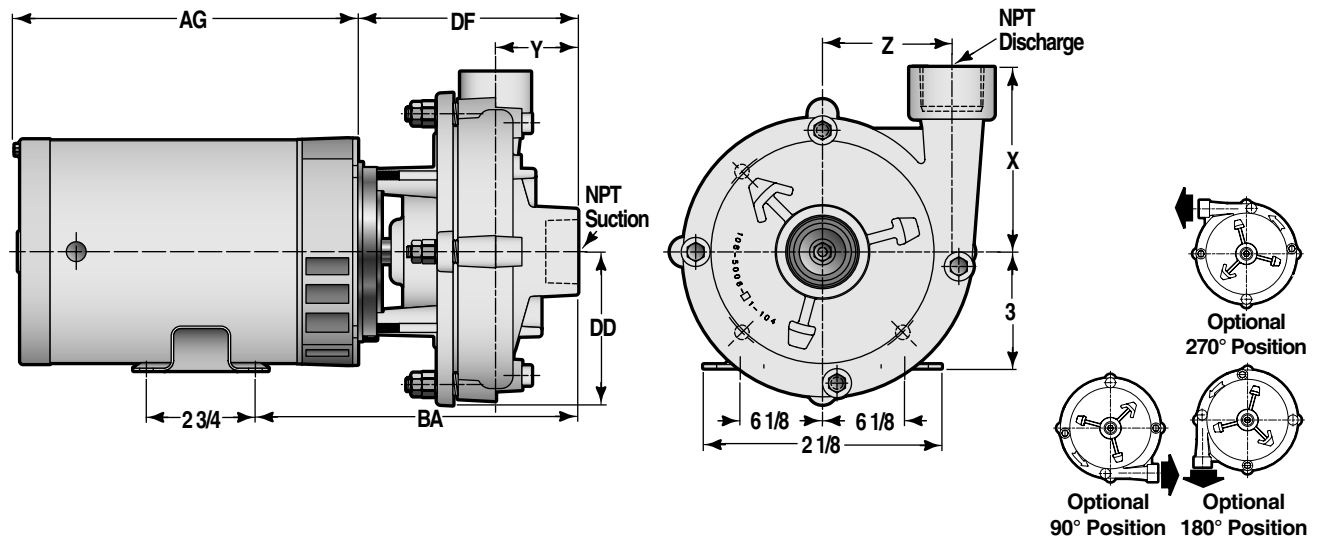

Pump Size				Single Phase ODP Motors							
Model	Disch.	Suction	Imp. Ø	DD	DF	X	Y	Z	Frame	BA	AG
C61AB	1/2	3/4	6	3 15/16	4 5/8	3 7/16	1 1/2	3 5/16	56 Frame (1 1/2 - 2 HP)	7 3/16	14 1/8
C61BC	3/4	1	6	3 15/16	4 7/16	3 15/16	1 5/16	3 1/4		7 3/4	13 5/8

NOTES: All dimensions in inches. May vary ± 1/4 inches. Not for construction purposes unless certified.

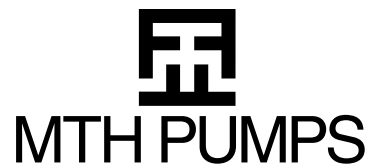

401 West Main Street • Plano, IL 60545-1436
 Phone: 630-552-4115 • Fax: 630-552-3688
 Email: SALES@MTHPUMPS.COM
 http://WWW.MTHPUMPS.COM

