

Model EHG

EHG

GAS BURNER



EHG features:

The Wayne Model EHG power gas burners are designed for performance and reliability, and offer features such as:

- Higher static pressure than standard power gas burners
- Good combustion in poor draft situations
- Converts easily to fire LP or Natural Gas
- Flame retention head to allow flame shapes to fit various combustion chambers
- Partial premix head design to provide excellent combustion characteristics (9 to 11% CO₂ on Natural Gas)
- Industry proven controls and components

Designed For Easy Serviceability:

- No need to remove the burner for normal service
Gas Gun assembly is easily removed for complete service or replacement of components
- Easy, external orifice change
- Automatic, perfect alignment of combustion components

Designed For Installation Flexibility:

- Just change the orifice and adjust to fire LP or Natural Gas through the full burner range from 425M to 700M Btu
- Complete range of marked orifice sizes supplied with each EHG burner
- Adjustable flange is standard
- Equipped with *Power On* and *Fuel On* indicator lights

Applications:

The EHG has a wide range of applications including boilers, furnaces, water heaters, incinerators, ovens, commercial cooking equipment, commercial dryers and parts washers.

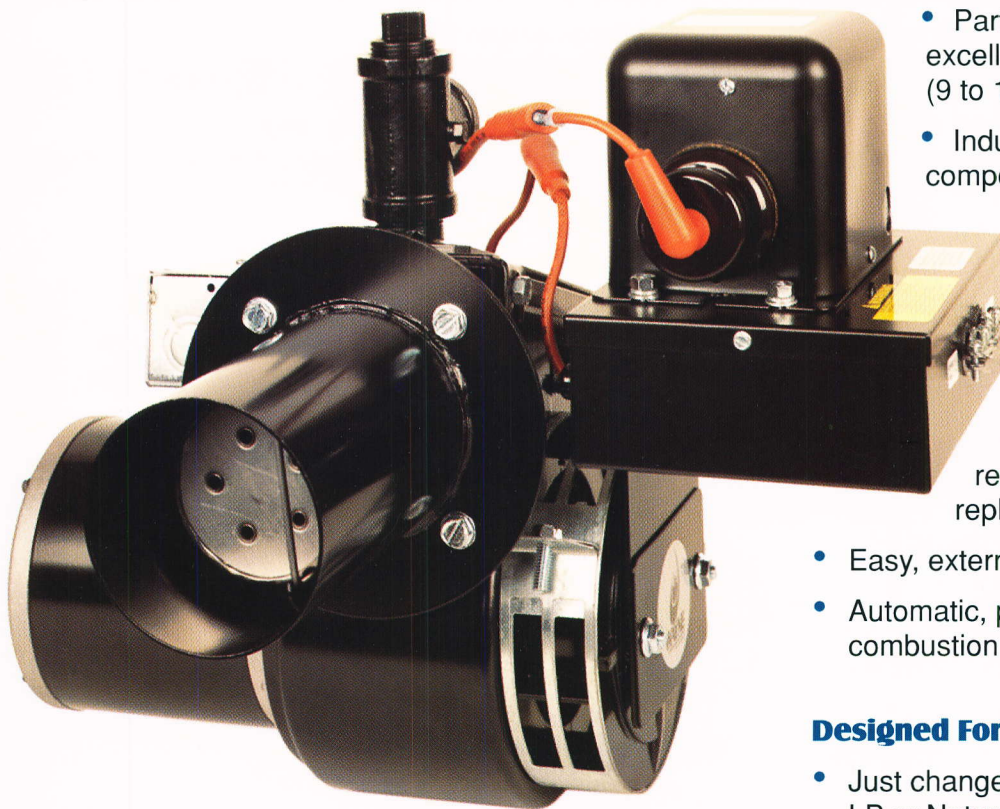

Certified to: UL795 & CGA 3.4

Specifications

EHG

GAS BURNER

POWER GAS BURNER - MODEL EHG

Capacities	Firing rates from 425M through 700M Btu.
Fuel	Natural or LP Gas
Controls	Honeywell S89G 2 rod direct ignition system. Flamerod sensor with 4 second trial for ignition.
Ignition	Direct spark ignition 10,000 volt ignition transformer. Other transformers available.
Motor	3450RPM – 115V.A.C.- 60Hz
Fan Housing	Aluminum alloy, die cast housing. Maintains alignment of all moving parts throughout lifetime of burner.
Mounting	Adjustable flange standard. Welded flange is optional.
Air Tube	4" OD available in standard lengths of 6", 9", 12" and 15".
Combustion Head	Stainless steel, precision stamping. No change for entire firing range.
Pipetrain	UL795 & CGA3.4 compliant

DIMENSIONS

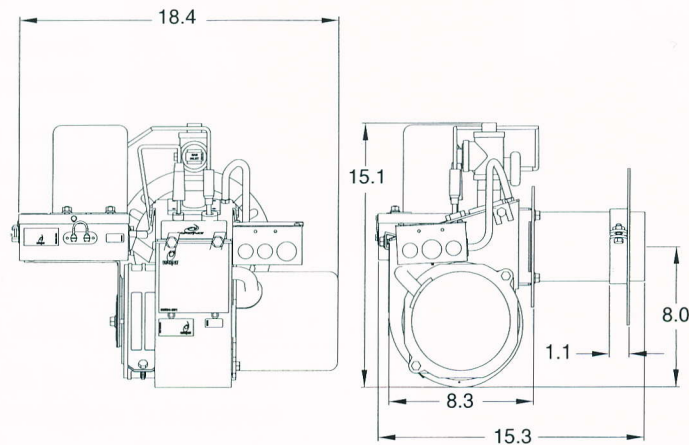

Complete Burner:

Model EHG flame retention gas burners are CSA certified as supplied with our UL795 & CGA3.4 compliant pipetrain. All EHG burners are test-fired prior to shipment. Complete burner includes additional orifices, an adjustable flange and gasket.

Shipping Information:

- Individually cartoned
- Burner weight: Up to 48 lbs.
- Pipetrain weight: 11 lbs.

