

## HDT

### Pilot-Operated Temperature Regulating Valve

Watson McDaniel reserves the right to change the designs and/or materials of its products without notice.  
©2010 Watson McDaniel Company

## HD Regulating Valve with "T" Temperature Pilot

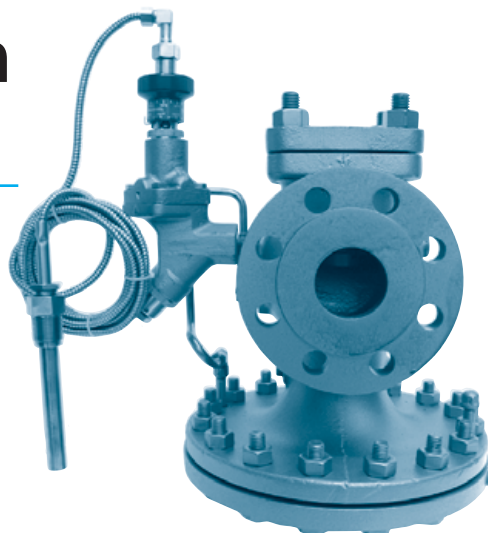

PILOT-OPERATED REGULATING VALVES

- Inlet Pressure Max: 300 PSIG
- Temperature Control Range: 60–260 °F
- Min Inlet Pressures:
  - 15 PSIG standard main valve with standard temperature pilot
  - 5 PSIG low pressure main valve with low pressure temp. pilot

**Low Pressure Temperature Pilot must be used in conjunction with a low pressure main valve for applications where inlet steam pressure is less than 15 PSIG. SPECIFY WHEN ORDERING.**

### TYPICAL APPLICATIONS

The HD Regulator with the "T" Temperature Pilot is used for controlling temperature in various processes and systems, such as Oil Heaters, Ovens, Process Heaters, Vats, Dryers and Jacketed Kettles.

### FEATURES

- Temperature adjustment made simple and easy by rotating an adjustment knob to the desired temperature setting
- Thermostatic sensing bulb comes with 8-ft. or 15-ft. capillary; optional lengths up to 25-ft. max
- Capillary is armor-protected to resist damage
- Optional stainless steel sensing bulb and capillary
- Overheat protection bellows is incorporated into sensing bulb; 200°F overheat protection up to 350°F
- Can be used with Pressure Pilot for simultaneous control of pressure and temperature
- Hardened stainless steel trim on regulator for extended service life
- Full port strainer and blowdown valve on pilot adapter for ultimate protection from dirt and scale

### OPTIONS

- Temperature Pilot can be combined with Pressure and Solenoid pilots
- Additional capillary lengths can be ordered in 5-ft. increments; up to 25-ft. maximum length
- Wells\* are available in 316 stainless steel
- Longer wells can be supplied
- Low pressure (under 15 PSIG) temperature pilot
- Consult factory for other options

### TEMPERATURE-ADJUSTING RANGES

Temperature Ranges *	Identifying Colors
60 - 120 °F (16 - 49 °C)	yellow
100 - 160 °F (38 - 71 °C)	black
120 - 180 °F (49 - 82 °C)	blue
160 - 220 °F (71 - 104 °C)	red
200 - 260 °F (93 - 127 °C)	green

\* Other ranges available; consult Factory.

### MATERIALS

Body	Ductile Iron
Cover	Ductile Iron
Gasket	Grafoil
Cover Screws	Steel
Pilot Adapter	Ductile Iron/Cast Steel
Screen	Stainless Steel
Tubing	Copper
Valve Seat	Hardened SST (55 Rc)
Valve Disc	Hardened SST (55 Rc)
Diaphragm	Phosphor Bronze

#### \* Thermowells:

Wells isolate sensing bulb from the process liquid and are available in Brass or Stainless Steel. When placed on the side of a tank or vessel, the sensing bulb can be removed without having to drain the process fluid.

## Pilot-Operated Temperature Regulating Valve

### DIMENSIONS HD-Series – inches / pounds

Size	Face-To-Face			B	C	D	E	Weight (lbs)	
	NPT	150#	300#					NPT	FLG
1/2"	43/8			5 1/2	9 1/4	6 1/2	6 1/2	18	
3/4"	43/8			5 1/2	9 1/4	6 1/2	6 1/2	18	
1"	53/8	5 1/2	6	6 1/4	9 1/4	7	8 1/4	23	35
1 1/4"	6 1/2			7 3/8	9 1/4	8 3/4	7 1/4	43	
1 1/2"	7 1/4	6 7/8	7 3/8	7 3/8	9 1/4	8 3/4	7 1/4	43	60
2"	7 1/2	8 1/2	9	8 1/4	9 1/4	10 7/8	7 1/2	65	85
2 1/2"		9 3/8	10	9	9 1/4	11 3/4	7 3/4		105
3"		10	10 3/4	8 7/8	9 1/4	13 1/4	8 1/2		145
4"		11 7/8	12 1/2	10 7/8	9 1/4	14 3/4	9 1/2		235
6"		15 1/8	16	14 1/8	9 3/4	19 3/4	10 3/4		470

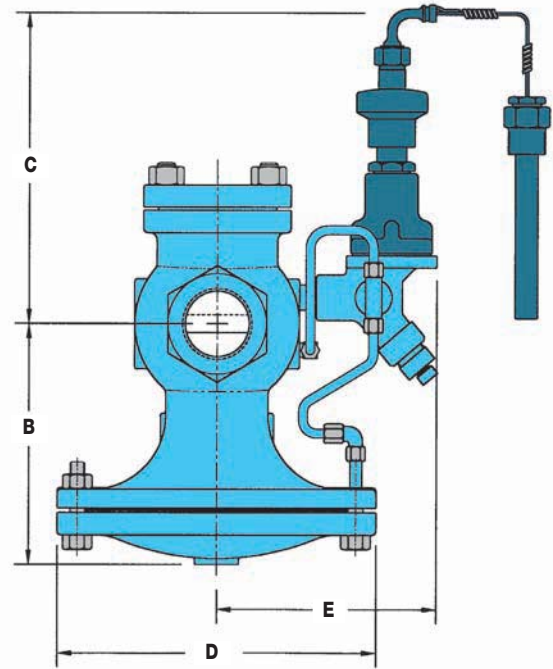

PILOT-OPERATED REGULATING VALVES

### HOW TO ORDER

#### "T" TEMPERATURE PILOT

Specify:

- Temperature range from the chart or indicate the set temperature of the process you wish to control
- The length of capillary required. 8-ft. or 15-ft. standard; Maximum length: 25-ft. in 5-ft. increments
- Bulb type needed: T, TU, TUBW, TUSW, TBW & TSW

#### REGULATOR BODY

Specify:

- HD regulator body
- Regulator size or capacity
- End connections (threaded, 150/300# flanged)

### MINIMUM OPERATING PRESSURES

Minimum Inlet Pressure:

- 15 PSIG** (Standard Main Valve with Standard Temperature Pilot)
- 5 PSIG** (Low Pressure Main Valve with Low Pressure Temperature Pilot)

**Low Pressure Temperature Pilot must be used in conjunction with a Low Pressure Main Valve for applications where inlet steam pressure is less than 15 PSIG. SPECIFY WHEN ORDERING.**

### HOW IT WORKS

The temperature pilot controls the operation of the temperature regulating valve. The temperature sensing bulb, which is filled with a temperature sensitive liquid, is placed in the process fluid that is being heated. When the temperature of the process fluid reaches its set point, the bellows expands and closes off the pilot valve. When the pilot valve is shut, steam can no longer pass thru to the underside of the regulator diaphragm, and the main valve closes. When the process fluid cools below the set temperature, the main valve reopens.

