



# TR5000-DT5

Treadmill Desk



DISPLAY READOUTS	Steps taken, walking time, calories burned, distance traveled, and walking belt speed
DESKTOP HEIGHT	41" - 56" (supports users 4'10" - 6'8")
HEIGHT ADJUSTMENT METHOD	Manual
WALKING BELT SPEED	0.4 - 4.0 MPH
WALKING SURFACE	20" W x 56" L maintenance free belt
SIDE RAILS	Aluminum
WARRANTY	<i>Ten hours maximum daily usage</i>
FRAME	Lifetime
MOTOR	3 Years
PARTS	2 Years
LABOR	1 Year

*Best Fit*

**USER WEIGHT** 100 - 400 lbs.

**USE PER DAY** 1 - 10 hours

**TOTAL USERS** 1-3

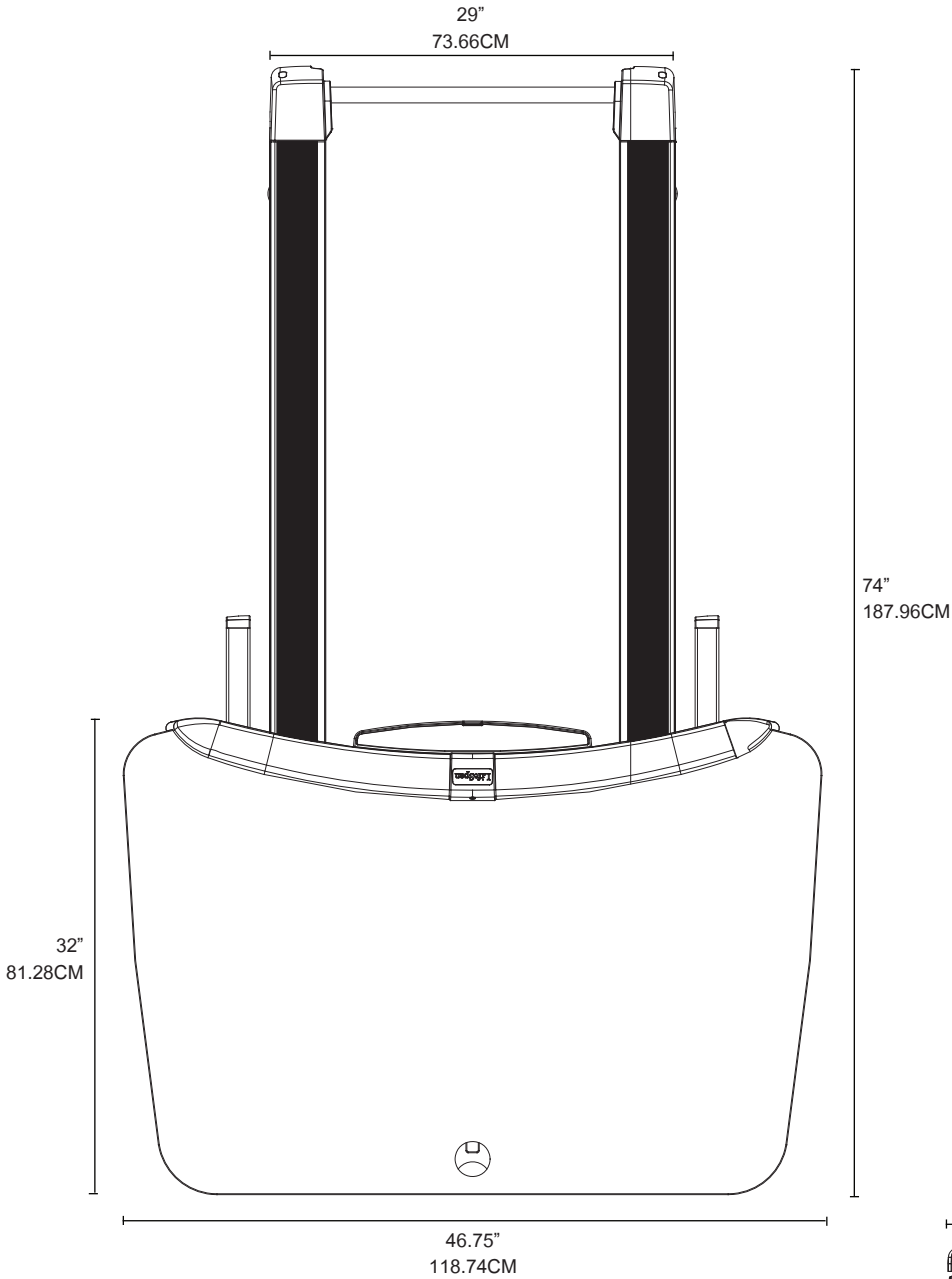

WWW.LIFESPANFITNESS.COM  
877.654.3837 OPTION 2  
50 BERKSHIRE COURT, SUITE 209  
WYOMISSING, PA 19610

PRODUCT **TR5000-DT5**

**COLORS**

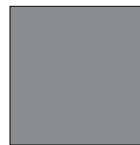
DESKTOP	FRAME
	
PANTONE® 3 C	PANTONE® 877 C

**DIMENSIONS**

DESKTOP	46.75" W x 32" D 118.74CM x 81.28CM
TREADMILL	70.25" L x 29" W x 9.5" H 178.43CM x 73.66CM x 24.13CM
ASSEMBLED	74" L x 46.75" W 187.96CM x 118.75CM

**WEIGHTS**

DESK	110 LBS/49.89 KG
TREADMILL	145 LBS/65.77 KG

