

Fig. 227

Top Beam Clamp

Material: Carbon steel jaw, hook rod with nut, lock washer and plain washer.

Finish: Plain

Service: Recommended for use on top flange of beam and roof trusses where the flange thickness does not exceed 0.81".

Approvals: Complies with Federal Specification A-A-1192A (Type 25), ANSI/MSS SP-69 and MSS SP-58 (Type 25). UL Listed (rod sizes $\frac{3}{8}$ " & $\frac{1}{2}$ ") and FM Approved when used with $\frac{3}{8}$ " rod size.

How to size: Determine hook rod length by adding figure in column headed "x" to flange width (see table on page 258 for flange width). "x" is not indicated as a dimension on drawing.

Installation: Slide stamped steel jaw over beam flange and attach hook rod and eye rod, finally tightening hook rod. Hammer jaw firmly against the underside of the beam to complete installation.

Features:

- Two jaw sizes fit beam flanges thickness from 0.25" to 0.81".
- Clamp firmly holds to beam providing safe and extremely economical means of supporting small piping from the top flange of steel beams and roof trusses.

Ordering: Specify jaw size, figure number, name, hook rod length. Standard hook rods are furnished in even inch lengths, either length ordered or next longer length.

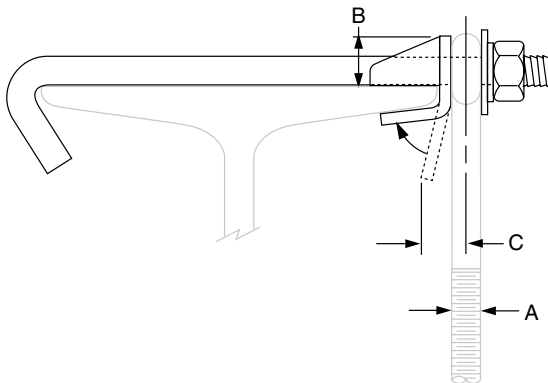

FIG. 227: LOADS (LBS) • WEIGHT (LBS) • DIMENSIONS (IN)

Jaw Size	Max Load	Weight ▲	Hook Rod Diam	Rod Size A	B	C	X
1	730	0.38	$\frac{3}{8}$	$\frac{3}{8}$	$\frac{3}{4}$	$\frac{5}{16}$	$2\frac{1}{8}$
2	940	0.67	$\frac{1}{2}$	$\frac{1}{2}$	1	$\frac{3}{8}$	$2\frac{1}{4}$
				$\frac{5}{8}$	$1\frac{1}{8}$	$\frac{7}{16}$	$2\frac{1}{2}$
				$\frac{3}{4}$	$1\frac{1}{4}$	$\frac{1}{2}$	$2\frac{5}{8}$

▲ Based on 8" hook rod length. Will vary for other hook rod lengths.