

GAS DISTRIBUTION PRODUCTS

STEEL SERVICE TEES



Continental Industries

A Division of  **BURNDY** LLC

The Ultimate Connection
www.conind.com

ABOUT US



Our Company

Continental Industries, headquartered in Tulsa , Oklahoma , was formed in 1958 and is today a leading manufacturer of connectors for the Gas Utility, Gas & Water Distribution, Propane, Plumbing and Cathodic Protection markets. An ISO 9001 certified company, Continental Industries has manufacturing locations in Tulsa and Broken Arrow , Oklahoma. Our employees are committed to providing the best value to our customers.

Our full line of plastic and steel connector products are produced utilizing state-of-the-art injection molding machines, automatic screw machines, and CNC machining equipment. Our commitment to quality is evident in every step of our business processes. Renowned for our design and development of technologically advanced products, we provide our customers with reliable, cost-effective solutions to their “main to meter” service line installation, repair, or renewal problems.

thermOweld® , our exothermic welding materials and accessories products, provide a simple, efficient, cost effective method of permanently connecting two or more conductors utilizing a high temperature exothermic reaction between Aluminum and Copper Oxide to produce an almost pure copper weld. We manufacture all of our weld metal and molds in Oklahoma so you are certain of getting consistent, high quality products to satisfy your exothermic welding needs.

Our Vision

Simply stated, our vision is “To be a Sales and Customer Driven Company” . Our commitment to providing the best value to our customers is shared by the entire organization and is evidenced by both the number of long standing relationships we have gratefully developed over the years and the new relationships we are developing every day.

Why Use

Continental Industries is the industry leader in the manufacturing of plastic and steel mechanical fittings for the Gas & Water industry. From the I.D. Seal® Con-Stab to Scope®, steel saddles to HVT, quality and service is what drives us at Continental Industries.

Manufacturing fittings since 1958, Continental has the experience and confidence necessary to provide the best quality products on the market today. Continental Industries’ mechanical fittings will save you both time and money and give you the peace of mind that comes with using a quality product.

Continental Industries’ uses only the highest quality raw materials, engineered designs and manufacturing processes to ensure the consistent quality that makes Continental Industries’ products second to none.

With regional sales offices located throughout the United States, a Continental Industries representative is only a phone call away to help with any questions you may have.

Come experience what so many other satisfied customers have experienced, the excitement and family atmosphere that is Continental Industries!

TABLE OF CONTENTS

Steel Service Punch Tees (with Seal Plug Cap).....	3-5
Steel Service Punch Tees (with Pipe Cap)	6-10
Steel Service Saddle Punch Tees (with Seal Plug Cap).....	11-14
Steel Service Saddle Punch Tees (with Pipe Cap).....	15-19
Punch Data - Sizes, Types & Limits.....	20
Accessories for Steel Service Punch Tees.....	21
Steel Service Safe-T Valve Tees	22-24
Accessories for Steel Service Safe-T Valve Tees.....	25
Protective Sleeves	26

For Con-Stab ID Seal® Transition Punch Tees, see Continental’s “Con-Stab ID Seal® Fittings” Catalog



STEEL SERVICE PUNCH TEES WITH SEAL PLUG CAP

The Most Foolproof, Versatile, Economical Punch Tee Available!

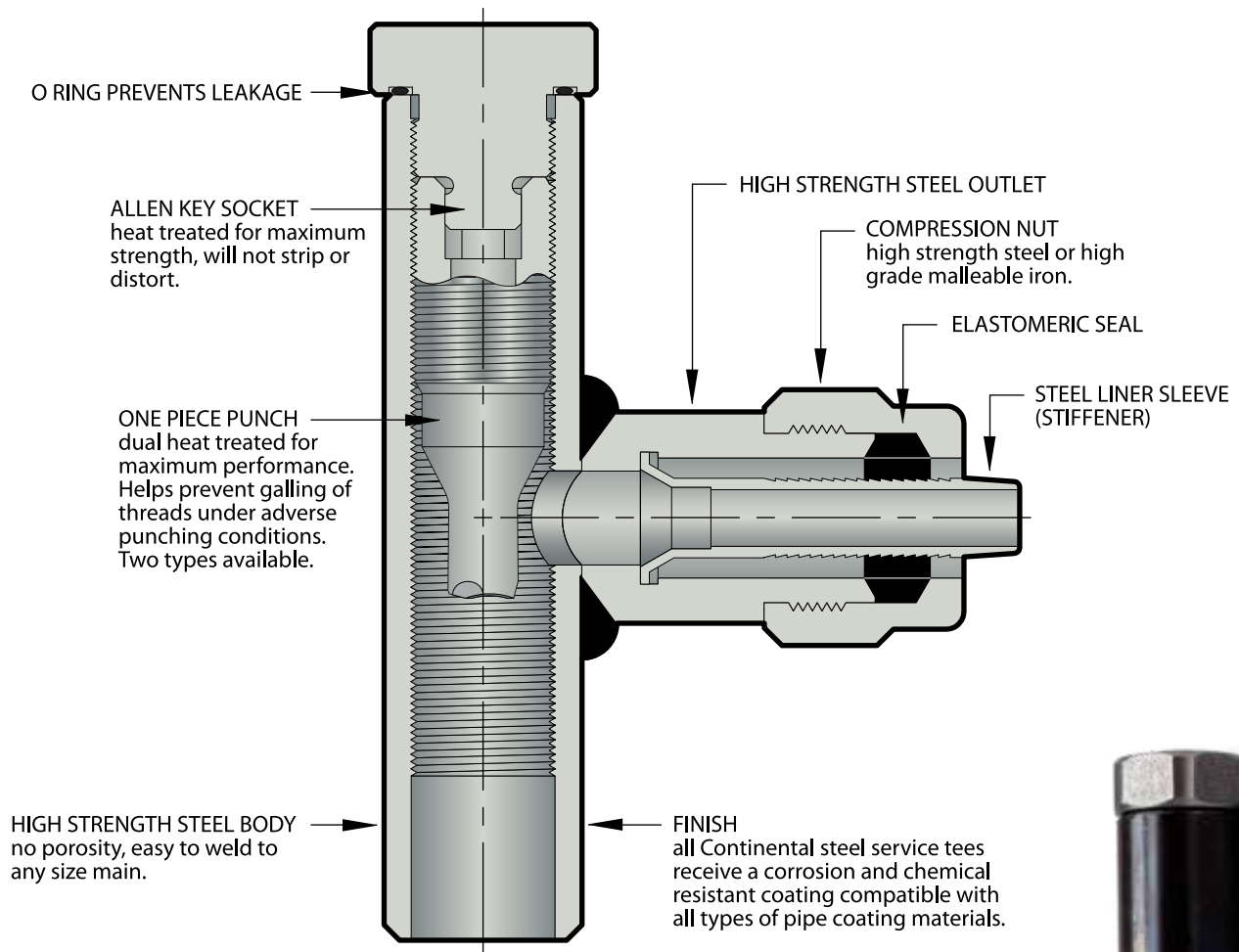

- CAP SCREWS DOWN INSIDE TEE BODY
- O-RING IN CAP PREVENTS LEAKAGE
- NO NEED FOR TEFLON TAPE OR THREAD SEALANT
- CAP CAN BE TIGHTENED BY HAND TO SEAL AT 800 PSI
- WELDS ARE TESTED TO 800 PSI
- PUNCH PROVIDES POSITIVE VALVE ACTION AT MAIN
- FAST - NO BULKY DRILLING EQUIPMENT NEEDED
- SAFE - NO BLOWING OF GAS
- CAN BE FURNISHED WITH ANY TYPE CONTINENTAL OUTLET
- TWO TYPES OF PUNCHES AVAILABLE (SEE PG 20)
- AVAILABLE IN WELD, THREADED OR SADDLE INLETS



PUNCH TEES

1201 & 1302 STYLE STEEL SERVICE PUNCH TEES PE Compression Outlets

OUTLET	WALL	INLET	PART NUMBER	PUNCH SIZE
1/2" CTS (5/8" OD)	.090	1/2" Weld	1201-09-1004-00	3/8" CR
		1/2" Threaded	1201-12-1004-00	
		3/4" Weld	1302-09-1004-00	
	.062	3/4" Threaded	1302-12-1004-00	
		1/2" Weld	1201-09-1004-0A	
		1/2" Threaded	1201-12-1004-0A	
1" CTS (1 1/8" OD)	.099/.101	3/4" Weld	1302-09-1008-00	3/8" CR
		3/4" Threaded	1302-12-1008-00	
		1/2" Weld	1201-09-1008-0A	
	.090	1/2" Threaded	1201-12-1008-0A	
		3/4" Weld	1302-09-1008-0A	
		3/4" Threaded	1302-12-1008-0A	
1/2" IPS	SDR-9.33 (.090)	1/2" Weld	1201-09-1012-00	3/8" CR
		1/2" Threaded	1201-12-1012-00	
		3/4" Weld	1302-09-1012-00	
		3/4" Threaded	1302-12-1012-00	
3/4" IPS	SDR-11 (.095)	1/2" Weld	1201-09-1013-00	3/8" CR
		1/2" Threaded	1201-12-1013-00	
		3/4" Weld	1302-09-1013-00	
		3/4" Threaded	1302-12-1013-00	
1" IPS	SDR-11 (.119)	3/4" Weld	1302-09-1014-00	3/8" CR
		3/4" Threaded	1302-12-1014-00	



- For sizes not listed, contact Continental Industries.
- PE Compression Outlets rated at 125 psig.
- For optional punch sizes, see page 20.
- Recommended accessories;
 - 23-3691-00 ~ 5/16" Hex Drive Key, Bushing and Socket Adapter for 1201 Style Tees (pg 21)
 - 23-3692-00 ~ 3/8" Hex Drive Key, Bushing and Socket Adapter for 1302 Style Tees (pg 21)
 - 23-1644-00 ~ Test Plug Adapter for 1201 Style Tees (pg 21)
 - 23-1645-00 ~ Test Plug Adapter for 1302 Style Tees (pg 21)
- For Protective Sleeves, see page 26.
- For additional Accessories, see page 21.



1201 & 1302 STYLE STEEL SERVICE PUNCH TEES Steel Tube or Pipe (Conductive) Compression Outlets

OUTLET	INLET	PART NUMBER	PUNCH SIZE
5/8" OD	1/2" Weld	1201-09-1304-00	3/8" CR
	1/2" Threaded	1201-12-1304-00	
	3/4" Weld	1302-09-1304-00	
	3/4" Threaded	1302-12-1304-00	
3/4" IPS	1/2" Weld	1201-09-0413-00	3/8" CR
	1/2" Threaded	1201-12-0413-00	
	3/4" Weld	1302-09-0413-00	
	3/4" Threaded	1302-12-0413-00	
1" IPS	3/4" Weld	1302-09-0414-00	3/8" CR
	3/4" Threaded	1302-12-0414-00	



- For sizes not listed, contact Continental Industries.
- Steel Tube or Pipe (Conductive) Compression Outlets rated at 300 psig.
- For optional punch sizes, see page 20.
- Recommended accessories;
 - 23-3691-00 ~ 5/16" Hex Drive Key, Bushing and Socket Adapter for 1201 Style Tees (pg 21)
 - 23-3692-00 ~ 3/8" Hex Drive Key, Bushing and Socket Adapter for 1302 Style Tees (pg 21)
 - 23-1644-00 ~ Test Plug Adapter for 1201 Style Tees (pg 21)
 - 23-1645-00 ~ Test Plug Adapter for 1302 Style Tees (pg 21)
- For additional Accessories, see page 21.





1201 & 1302 STYLE STEEL SERVICE PUNCH TEES Weld Outlets

OUTLET	INLET	PART NUMBER	PUNCH SIZE
1/2" IPS Butt Weld or 3/4" IPS Fillet Weld	1/2" Weld	1201-09-0612-00	3/8" CR
	1/2" Threaded	1201-12-0612-00	
1/2" IPS Socket Weld	3/4" Weld	1302-09-0712-00	3/8" CR
	3/4" Threaded	1302-12-0712-00	
3/4" IPS Socket Weld	3/4" Weld	1302-09-0713-00	3/8" CR
	3/4" Threaded	1302-12-0713-00	
3/4" IPS Plain for Butt Welding	3/4" Weld	1302-09-0813-00	3/8" CR
	3/4" Threaded	1302-12-0813-00	
1" IPS Plain for Butt Welding	3/4" Weld	1302-09-0814-00	3/8" CR
	3/4" Threaded	1302-12-0814-00	

- For sizes not listed, contact Continental Industries.
- Weld Outlets rated at 500 psig.
- For optional punch sizes, see page 20.
- Recommended accessories;
 - 23-3691-00 ~ 5/16" Hex Drive Key, Bushing and Socket Adapter for 1201 Style Tees (pg 21)
 - 23-3692-00 ~ 3/8" Hex Drive Key, Bushing and Socket Adapter for 1302 Style Tees (pg 21)
 - 23-1644-00 ~ Test Plug Adapter for 1201 Style Tees (pg 21)
 - 23-1645-00 ~ Test Plug Adapter for 1302 Style Tees (pg 21)
- For additional Accessories, see page 21.

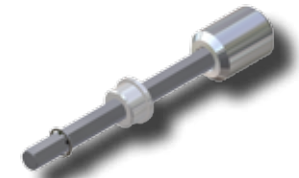

23-3691-00 & 23-3692-00
Hex Drive Key, Bushing and Socket Adapter
for 1201 & 1302 Style Tees (pg 21)

1201 & 1302 STYLE STEEL SERVICE PUNCH TEES Threaded Outlets

OUTLET	INLET	PART NUMBER	PUNCH SIZE
1/2" IPS Male Pipe Thread	1/2" Weld	1201-09-0912-00	3/8" CR
	1/2" Threaded	1201-12-0912-00	
3/4" IPS Male Pipe Thread	3/4" Weld	1302-09-0913-00	3/8" CR
	3/4" Threaded	1302-12-0913-00	
1/2" IPS Female Pipe Thread	1/2" Weld	1201-09-1512-00	3/8" CR
	1/2" Threaded	1201-12-1512-00	
3/4" IPS Female Pipe Thread	3/4" Weld	1302-09-1513-00	3/8" CR
	3/4" Threaded	1302-12-1513-00	

- For sizes not listed, contact Continental Industries.
- Threaded Outlets rated at 500 psig.
- For optional punch sizes, see page 20.
- Recommended accessories;
 - 23-3691-00 ~ 5/16" Hex Drive Key, Bushing and Socket Adapter for 1201 Style Tees (pg 21)
 - 23-3692-00 ~ 3/8" Hex Drive Key, Bushing and Socket Adapter for 1302 Style Tees (pg 21)
 - 23-1644-00 ~ Test Plug Adapter for 1201 Style Tees (pg 21)
 - 23-1645-00 ~ Test Plug Adapter for 1302 Style Tees (pg 21)
- For additional Accessories, see page 21.

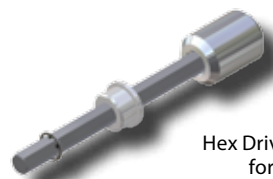

23-3691-00 & 23-3692-00
Hex Drive Key, Bushing and Socket Adapter
for 1201 & 1302 Style Tees (pg 21)

PUNCH TEES



STEEL SERVICE PUNCH TEES WITH PIPE CAP

The Most Foolproof, Versatile, Economical Punch Tee Available!

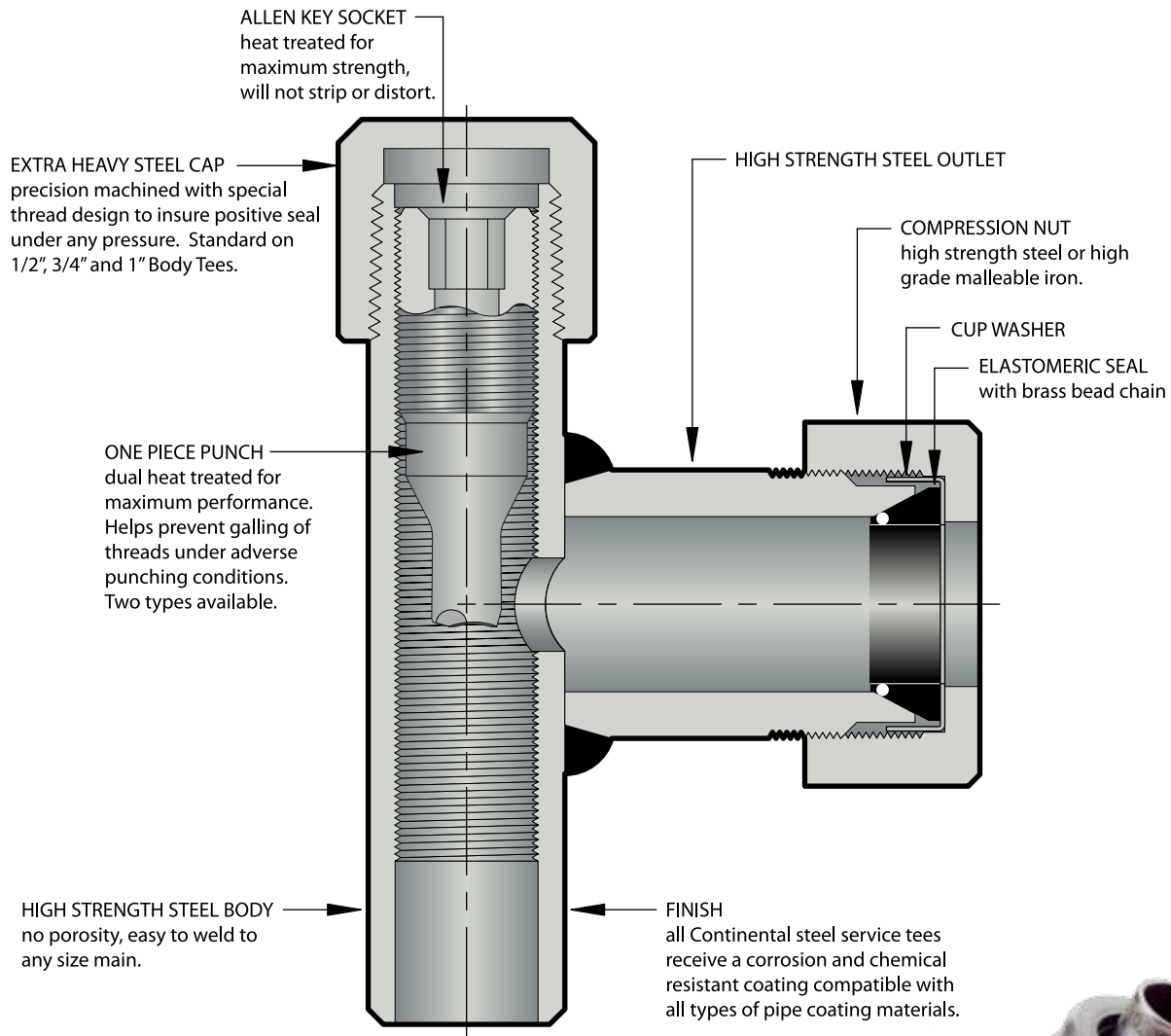

- WELDS ARE TESTED TO 800 PSI
- PUNCH PROVIDES POSITIVE VALVE ACTION AT MAIN
- FAST - NO BULKY DRILLING EQUIPMENT NEEDED
- SAFE - NO BLOWING OF GAS
- CAN BE FURNISHED WITH ANY TYPE CONTINENTAL OUTLET
- TWO TYPES OF PUNCHES AVAILABLE (SEE PG 20)
- AVAILABLE IN WELD, THREADED OR SADDLE INLETS





PUNCH TEES

1214, 1315, 1416 & 1517 STYLE STEEL SERVICE PUNCH TEES PE Compression Outlets

OUTLET	WALL	INLET	PART NUMBER	PUNCH SIZE
1/2" CTS (5/8" OD)	.090	1/2" Weld	1214-09-1004-00†	3/8" CR
		1/2" Threaded	1214-12-1004-00†	
		3/4" Weld	1315-09-1004-00†	
		3/4" Threaded	1315-12-1004-00†	
	.062	1/2" Weld	1214-09-1004-0A	
		1/2" Threaded	1214-12-1004-0A	
3/4" Weld		1315-09-1004-0A		
1" CTS (1 1/8" OD)	.099/.101	1/2" Weld	1214-09-1008-00	3/8" CR
		1/2" Threaded	1214-12-1008-00	
		3/4" Weld	1315-09-1008-00†	
		3/4" Threaded	1315-12-1008-00†	
	.090	1" Weld	1416-09-1008-00	3/4" CR
		1" Threaded	1416-12-1008-00	
		1/2" Weld	1214-09-1008-0A	3/8" CR
		1/2" Threaded	1214-12-1008-0A	
		3/4" Weld	1315-09-1008-0A	
		3/4" Threaded	1315-12-1008-0A	
1" Weld	1416-09-1008-0A	3/4" CR		
	1" Threaded		1416-12-1008-0A	
1/2" IPS	SDR-9.33 (.090)	1/2" Weld	1214-09-1012-00†	3/8" CR
		1/2" Threaded	1214-12-1012-00†	
		3/4" Weld	1315-09-1012-00†	
		3/4" Threaded	1315-12-1012-00†	
3/4" IPS	SDR-11 (.095)	1/2" Weld	1214-09-1013-00	3/8" CR
		1/2" Threaded	1214-12-1013-00	
		3/4" Weld	1315-09-1013-00†	
		3/4" Threaded	1315-12-1013-00†	
		1" Weld	1416-09-1013-00	3/4" CR
1" Threaded	1416-12-1013-00			
1" IPS	SDR-11 (.119)	3/4" Weld	1315-09-1014-00†	3/8" CR
		3/4" Threaded	1315-12-1014-00†	
		1" Weld	1416-09-1014-00	3/4" CR
		1" Threaded	1416-12-1014-00	
1 1/4" IPS	SDR-11 (.151)	1 1/4" Weld	1517-09-1015-0A	1" CR
		1 1/4" Threaded	1517-12-1015-0A	
	SDR-10 (.166)	1 1/4" Weld	1517-09-1015-00	
		1 1/4" Threaded	1517-12-1015-00	



- For sizes not listed, contact Continental Industries.
- PE Compression Outlets rated at 125 psig.
- For optional punch sizes, see page 20.
- Recommended accessories;
 - 23-3691-00 ~ 5/16" Hex Drive Key, Bushing and Socket Adapter for 1214 Style Tees (pg 21)
 - 23-3692-00 ~ 3/8" Hex Drive Key, Bushing and Socket Adapter for 1315 Style Tees (pg 21)
 - 23-0941-00 ~ 1/2" Square Drive Key, Bushing and Socket Adapter for 1416 Style Tees (pg 21)
 - 23-0940-00 ~ 1/2" Square Drive Key, Bushing and Socket Adapter for 1517 Style Tees (pg 21)
- For Protective Sleeves, see page 26.
- For additional Accessories, see page 21.
- † = CSA Approved

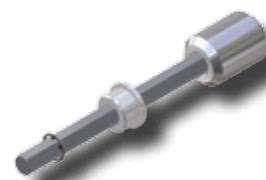

23-3691-00 & 23-3692-00
Hex Drive Key, Bushing and Socket Adapter
for 1214 & 1315 Style Tees (pg 21)



23-0941-00 & 23-0940-00
Hex Drive Key, Bushing and Socket Adapter
for 1416 Style Tees (pg 21)

PUNCH TEES

1214, 1315, 1416 & 1517 STYLE STEEL SERVICE PUNCH TEES Steel Tube or Pipe (Conductive) Compression Outlets

OUTLET	INLET	PART NUMBER	PUNCH SIZE
5/8" OD	1/2" Weld	1214-09-1304-00	3/8" CR
	1/2" Threaded	1214-12-1304-00	
	3/4" Weld	1315-09-1304-00	
	3/4" Threaded	1315-12-1304-00	
3/4" IPS	1/2" Weld	1214-09-0413-00	3/8" CR
	1/2" Threaded	1214-12-0413-00	
	3/4" Weld	1315-09-0413-00	
	3/4" Threaded	1315-12-0413-00	
	1" Weld	1416-09-0413-00	3/4" CR
	1" Threaded	1416-12-041300	
1" IPS	3/4" Weld	1315-09-0414-00	3/8" CR
	3/4" Threaded	1315-12-0414-00	
	1" Weld	1416-09-0414-00	3/4" CR
	1" Threaded	1416-12-0414-00	
1 1/4" IPS	1 1/4" Weld	1517-09-0415-00	1" CR
	1 1/4" Threaded	1517-12-0415-00	

- For sizes not listed, contact Continental Industries.
- Steel Tube or Pipe (Conductive) Compression Outlets rated at 300 psig.
- For optional punch sizes, see page 20.
- Recommended accessories;
 - 23-3691-00 ~ 5/16" Hex Drive Key, Bushing and Socket Adapter for 1214 Style Tees (pg 21)
 - 23-3692-00 ~ 3/8" Hex Drive Key, Bushing and Socket Adapter for 1315 Style Tees (pg 21)
 - 23-0941-00 ~ 1/2" Square Drive Key, Bushing and Socket Adapter for 1416 Style Tees (pg 21)
 - 23-0940-00 ~ 1/2" Square Drive Key, Bushing and Socket Adapter for 1517 Style Tees (pg 21)
- For additional Accessories, see page 21.

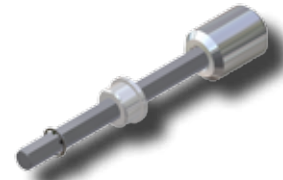

23-3691-00 & 23-3692-00
Hex Drive Key, Bushing and Socket Adapter
for 1214 & 1315 Style Tees (pg 21)

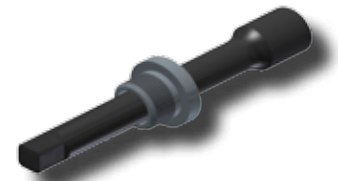

23-0941-00 & 23-0940-00
Hex Drive Key, Bushing and Socket Adapter
for 1416 & 1517 Style Tees (pg 21)



1214 Style Tee Shown with 23-3691-00 Hex Drive Key Assembly



PUNCH TEES

1214, 1315, 1416 & 1517 STYLE STEEL SERVICE PUNCH TEES Weld Outlets

OUTLET	INLET	PART NUMBER	PUNCH SIZE
1/2" IPS Butt Weld or 3/4" IPS Fillet Weld	1/2" Weld	1214-09-0612-00	3/8" CR
	1/2" Threaded	1214-12-0612-00	
1/2" IPS Socket Weld	3/4" Weld	1315-09-0712-00	3/8" CR
	3/4" Threaded	1315-12-0712-00	
3/4" IPS Socket Weld	3/4" Weld	1315-09-0713-00	3/8" CR
	3/4" Threaded	1315-12-0713-00	
3/4" IPS Plain for Butt Welding	3/4" Weld	1315-09-0813-00	3/8" CR
	3/4" Threaded	1315-12-0813-00	
	1" Weld	1416-09-0813-00	3/4" CR
	1" Threaded	1416-12-0813-00	
1" IPS Plain for Butt Welding	3/4" Weld	1315-09-0814-00	3/8" CR
	3/4" Threaded	1315-12-0814-00	
	1" Weld	1416-09-0814-00	3/4" CR
	1" Threaded	1416-12-0814-00	
	3/4" Weld	1315-09-0815-00	3/8" CR
1 1/4" IPS Plain for Butt Welding	3/4" Threaded	1315-12-0815-00	
	1" Weld	1416-09-0815-00	3/4" CR
	1" Threaded	1416-12-0815-00	
	1 1/4" Weld	1517-09-0815-00	1" CR
	1 1/4" Threaded	1517-12-0815-00	
2" IPS Plain for Butt Welding	1 1/4" Weld	1517-09-0817-00	1" CR
	1 1/4" Threaded	1517-12-0817-00	

- For sizes not listed, contact Continental Industries.
- Weld Outlets rated at 500 psig.
- For optional punch sizes, see page 20.
- Recommended accessories;
 - 23-3691-00 ~ 5/16" Hex Drive Key, Bushing and Socket Adapter for 1214 Style Tees (pg 21)
 - 23-3692-00 ~ 3/8" Hex Drive Key, Bushing and Socket Adapter for 1315 Style Tees (pg 21)
 - 23-0941-00 ~ 1/2" Square Drive Key, Bushing and Socket Adapter for 1416 Style Tees (pg 21)
 - 23-0940-00 ~ 1/2" Square Drive Key, Bushing and Socket Adapter for 1517 Style Tees (pg 21)
- For additional Accessories, see page 21.



23-3691-00, 23-3692-00, 23-0941-00 & 23-0940-00
Hex Drive Key, Bushing and Socket Adapter for
1214, 1315, 1416 & 1517 Style Tees (pg 21)

1214, 1315, 1416 & 1517 STYLE STEEL SERVICE PUNCH TEES Threaded Outlets

OUTLET	INLET	PART NUMBER	PUNCH SIZE
1/2" IPS Male Pipe Thread	1/2" Weld	1214-09-0912-00	3/8" CR
	1/2" Threaded	1214-12-0912-00	
3/4" IPS Male Pipe Thread	3/4" Weld	1315-09-0913-00	3/8" CR
	3/4" Threaded	1315-12-0913-00	
1" IPS Male Pipe Thread	1" Weld	1416-09-0914-00	3/4" CR
	1" Threaded	1416-12-0914-00	
3/4" IPS Female Pipe Thread	3/4" Weld	1315-09-1513-00	3/8" CR
	3/4" Threaded	1315-12-1513-00	
1" IPS Female Pipe Thread	1" Weld	1416-09-1514-00	3/4" CR
	1" Threaded	1416-12-1514-00	
1 1/4" IPS Female Pipe Thread	1 1/4" Weld	1517-09-1515-00	1" CR
	1 1/4" Threaded	1517-12-1515-00	

- For sizes not listed, contact Continental Industries.
- Threaded Outlets rated at 500 psig.
- For optional punch sizes, see page 20.
- Recommended accessories;
 - 23-3691-00 ~ 5/16" Hex Drive Key, Bushing and Socket Adapter for 1214 Style Tees (pg 21)
 - 23-3692-00 ~ 3/8" Hex Drive Key, Bushing and Socket Adapter for 1315 Style Tees (pg 21)
 - 23-0941-00 ~ 1/2" Square Drive Key, Bushing and Socket Adapter for 1416 Style Tees (pg 21)
 - 23-0940-00 ~ 1/2" Square Drive Key, Bushing and Socket Adapter for 1517 Style Tees (pg 21)
- For additional Accessories, see page 21.



23-3691-00, 23-3692-00, 23-0941-00 & 23-0940-00
Hex Drive Key, Bushing and Socket Adapter for
1214, 1315, 1416 & 1517 Style Tees (pg 21)

SADDLE PUNCH TEES



STEEL SERVICE SADDLE PUNCH TEES WITH SEAL PLUG CAP

The Most Foolproof, Versatile, Economical Punch Tee Available!

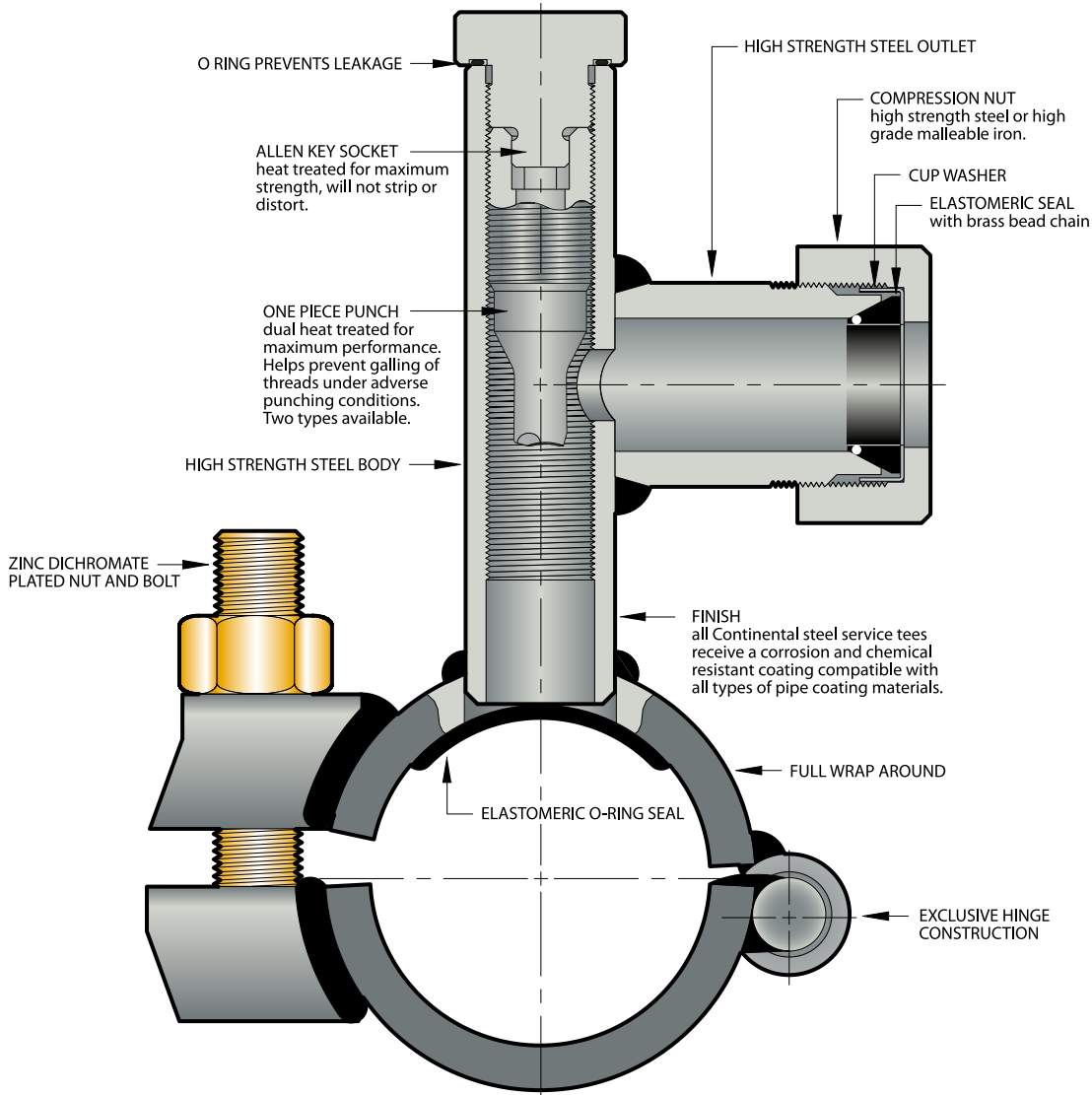

➤ SAME GREAT FEATURES FOUND ON THE SEAL PLUG CAP STYLE PUNCH TEES (SEE PAGE 3)

PLUS THE SADDLE PROVIDES;

- RUGGED ALL STEEL CONSTRUCTION
- FULL WRAP AROUND
- ELASTOMERIC O-RING SEAL
- EXCLUSIVE HINGE CONSTRUCTION
- USES SINGLE ZINC DICHROMATE PLATED NUT AND BOLT
- CAN BE USED FOR KEY HOLE APPLICATIONS

NOTE: STANDARD SADDLES TEES ARE FURNISHED WITH OUTLET PERPENDICULAR TO THE MAIN.
CONTACT CONTINENTAL FOR OUTLETS PARALLEL TO THE MAIN.



SADDLE PUNCH TEES

1201 & 1302 STYLE STEEL SERVICE SADDLE PUNCH TEES PE Compression Outlets

OUTLET	WALL	Body Size	IPS Main Size	PUNCH SIZE	PART NUMBER	
1/2" CTS (5/8" OD)	.090	1/2"	3/4"	3/8" CR	1201-13-1004-00	
		3/4"			1302-13-1004-00	
		1/2"	1"	3/8" CR	1201-14-1004-00	
		3/4"			1302-14-1004-00	
		1/2"	1 1/4"	3/8" CR	1201-15-1004-00	
		3/4"			1302-15-1004-00	
		1/2"	1 1/2"	3/8" CR	1201-16-1004-00	
		3/4"			1302-16-1004-00	
		1/2"	2"	3/8" CR	1201-17-1004-00	
		3/4"			1302-17-1004-00	
		1/2"	3"	3/8" CR	1201-19-1004-00	
		3/4"			1302-19-1004-00	
		1/2"	4"	3/8" CR	1201-21-1004-00	
		3/4"			1302-21-1004-00	
1/2"	6"	3/8" CR	1201-24-1004-00			
3/4"			1302-24-1004-00			
1" CTS (1 1/8" OD)	.099/.101	1/2"	3/4"	3/8" CR	1201-13-1008-00	
		3/4"			1302-13-1008-00	
		1/2"	1"	3/8" CR	1201-14-1008-00	
		3/4"			1302-14-1008-00	
		1/2"	1 1/4"	3/8" CR	1201-15-1008-00	
		3/4"			1302-15-1008-00	
		1/2"	1 1/2"	3/8" CR	1201-16-1008-00	
		3/4"			1302-16-1008-00	
		1/2"	2"	3/8" CR	1201-17-1008-00	
		3/4"			1302-17-1008-00	
		1/2"	3"	3/8" CR	1201-19-1008-00	
		3/4"			1302-19-1008-00	
		1/2"	4"	3/8" CR	1201-21-1008-00	
		3/4"			1302-21-1008-00	
	1/2"	6"	3/8" CR	1201-24-1008-00		
	3/4"			1302-24-1008-00		
	.090	.090	1/2"	3/4"	3/8" CR	1201-13-1008-0A
			3/4"			1302-13-1008-0A
			1/2"	1"	3/8" CR	1201-14-1008-0A
			3/4"			1302-14-1008-0A
			1/2"	1 1/4"	3/8" CR	1201-15-1008-0A
			3/4"			1302-15-1008-0A
			1/2"	1 1/2"	3/8" CR	1201-16-1008-0A
			3/4"			1302-16-1008-0A
			1/2"	2"	3/8" CR	1201-17-1008-0A
			3/4"			1302-17-1008-0A
			1/2"	3"	3/8" CR	1201-19-1008-0A
			3/4"			1302-19-1008-0A
1/2"			4"	3/8" CR	1201-21-1008-0A	
3/4"					1302-21-1008-0A	
1/2"	6"	3/8" CR	1201-24-1008-0A			
3/4"			1302-24-1008-0A			

OUTLET	WALL	Body Size	IPS Main Size	PUNCH SIZE	PART NUMBER
1/2" IPS	SDR-9.33 (.090)	1/2"	3/4"	3/8" CR	1201-13-1012-00
		3/4"			1302-13-1012-00
		1/2"	1"	3/8" CR	1201-14-1012-00
		3/4"			1302-14-1012-00
		1/2"	1 1/4"	3/8" CR	1201-15-1012-00
		3/4"			1302-15-1012-00
		1/2"	1 1/2"	3/8" CR	1201-16-1012-00
		3/4"			1302-16-1012-00
		1/2"	2"	3/8" CR	1201-17-1012-00
		3/4"			1302-17-1012-00
		1/2"	3"	3/8" CR	1201-19-1012-00
		3/4"			1302-19-1012-00
		1/2"	4"	3/8" CR	1201-21-1012-00
		3/4"			1302-21-1012-00
1/2"	6"	3/8" CR	1201-24-1012-00		
3/4"			1302-24-1012-00		
3/4" IPS	SDR-11 (.095)	1/2"	3/4"	3/8" CR	1201-13-1013-00
		3/4"			1302-13-1013-00
		1/2"	1"	3/8" CR	1201-14-1013-00
		3/4"			1302-14-1013-00
		1/2"	1 1/4"	3/8" CR	1201-15-1013-00
		3/4"			1302-15-1013-00
		1/2"	1 1/2"	3/8" CR	1201-16-1013-00
		3/4"			1302-16-1013-00
		1/2"	2"	3/8" CR	1201-17-1013-00
		3/4"			1302-17-1013-00
		1/2"	3"	3/8" CR	1201-19-1013-00
		3/4"			1302-19-1013-00
		1/2"	4"	3/8" CR	1201-21-1013-00
		3/4"			1302-21-1013-00
1/2"	6"	3/8" CR	1201-24-1013-00		
3/4"			1302-24-1013-00		
1" IPS	SDR-11 (.119)	3/4"	3/4"	3/8" CR	1302-13-1014-00
		3/4"	1"	3/8" CR	1302-14-1014-00
		3/4"	1 1/4"	3/8" CR	1302-15-1014-00
		3/4"	1 1/2"	3/8" CR	1302-16-1014-00
		3/4"	2"	3/8" CR	1302-17-1014-00
		3/4"	3"	3/8" CR	1302-19-1014-00
		3/4"	4"	3/8" CR	1302-21-1014-00
		3/4"	6"	3/8" CR	1302-24-1014-00

- For sizes not listed, contact Continental Industries.
- PE Compression Outlets rated at 125 psig.
- For optional punch sizes, see page 20.
- Recommended accessories;
 - 23-3691-00 ~ 5/16" Hex Drive Key, Bushing and Socket Adapter for 1201 Style Tees (pg 21)
 - 23-3692-00 ~ 3/8" Hex Drive Key, Bushing and Socket Adapter for 1302 Style Tees (pg 21)
 - 23-1644-00 ~ Test Plug Adapter for 1201 Style Tees (pg 21)
 - 23-1645-00 ~ Test Plug Adapter for 1302 Style Tees (pg 21)
- For Protective Sleeves, see page 26.
- For additional Accessories, see page 21.

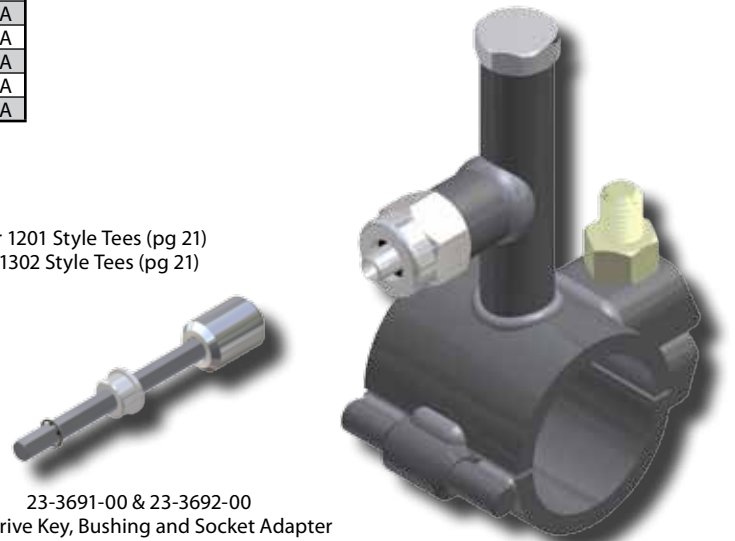

23-3691-00 & 23-3692-00
Hex Drive Key, Bushing and Socket Adapter
for 1201 & 1302 Style Tees (pg 21)

SADDLE PUNCH TEES



1201 & 1302 STYLE STEEL SERVICE SADDLE PUNCH TEES Steel Tube or Pipe (Conductive) Compression Outlets

OUTLET	Body Size	IPS Main Size	PUNCH SIZE	PART NUMBER
5/8" OD	1/2"	3/4"	3/8" CR	1201-13-1304-00
	3/4"			1302-13-1304-00
	1/2"	1"	3/8" CR	1201-14-1304-00
	3/4"			1302-14-1304-00
	1/2"	1 1/4"	3/8" CR	1201-15-1304-00
	3/4"			1302-15-1304-00
	1/2"	1 1/2"	3/8" CR	1201-16-1304-00
	3/4"			1302-16-1304-00
	1/2"	2"	3/8" CR	1201-17-1304-00
	3/4"			1302-17-1304-00
	1/2"	3"	3/8" CR	1201-19-1304-00
	3/4"			1302-19-1304-00
1/2"	4"	3/8" CR	1201-21-1304-00	
3/4"			1302-21-1304-00	
1/2"	6"	3/8" CR	1201-24-1304-00	
3/4"			1302-24-1304-00	
3/4" IPS	1/2"	3/4"	3/8" CR	1201-13-0413-00
	3/4"			1302-13-0413-00
	1/2"	1"	3/8" CR	1201-14-0413-00
	3/4"			1302-14-0413-00
	1/2"	1 1/4"	3/8" CR	1201-15-0413-00
	3/4"			1302-15-0413-00
	1/2"	1 1/2"	3/8" CR	1201-16-0413-00
	3/4"			1302-16-0413-00
	1/2"	2"	3/8" CR	1201-17-0413-00
	3/4"			1302-17-0413-00
	1/2"	3"	3/8" CR	1201-19-0413-00
	3/4"			1302-19-0413-00
1/2"	4"	3/8" CR	1201-21-0413-00	
3/4"			1302-21-0413-00	
1/2"	6"	3/8" CR	1201-24-0413-00	
3/4"			1302-24-0413-00	
1" IPS	3/4"	1 1/4"	3/8" CR	1302-15-0414-00
	3/4"	1 1/2"	3/8" CR	1302-16-0414-00
	3/4"	2"	3/8" CR	1302-17-0414-00
	3/4"	3"	3/8" CR	1302-19-0414-00
	3/4"	4"	3/8" CR	1302-21-0414-00
	3/4"	6"	3/8" CR	1302-24-0414-00

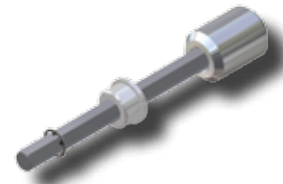

23-3691-00 & 23-3692-00
Hex Drive Key, Bushing and Socket Adapter
for 1201 & 1302 Style Tees (pg 21)

- For sizes not listed, contact Continental Industries.
- Steel Tube or Pipe Compression Outlets rated at 300 psig.
- For optional punch sizes, see page 20.
- Recommended accessories;
 - 23-3691-00 ~ 5/16" Hex Drive Key, Bushing and Socket Adapter for 1201 Style Tees (pg 21)
 - 23-3692-00 ~ 3/8" Hex Drive Key, Bushing and Socket Adapter for 1302 Style Tees (pg 21)
 - 23-1644-00 ~ Test Plug Adapter for 1201 Style Tees (pg 21)
 - 23-1645-00 ~ Test Plug Adapter for 1302 Style Tees (pg 21)
- For additional Accessories, see page 21.



SADDLE PUNCH TEES

1201 & 1302 STYLE STEEL SERVICE SADDLE PUNCH TEES Weld Outlets

OUTLET	Body Size	IPS Main Size	PUNCH SIZE	PART NUMBER
1/2" IPS Butt Weld or 3/4" IPS Fillet Weld	1/2"	3/4"	3/8" CR	1201-13-0612-00
	1/2"	1"	3/8" CR	1201-14-0612-00
	1/2"	1 1/4"	3/8" CR	1201-15-0612-00
	1/2"	1 1/2"	3/8" CR	1201-16-0612-00
	1/2"	2"	3/8" CR	1201-17-0612-00
	1/2"	3"	3/8" CR	1201-19-0612-00
	1/2"	4"	3/8" CR	1201-21-0612-00
1/2" IPS Socket Weld	3/4"	3/4"	3/8" CR	1302-13-0712-00
	3/4"	1"	3/8" CR	1302-14-0712-00
	3/4"	1 1/4"	3/8" CR	1302-15-0712-00
	3/4"	1 1/2"	3/8" CR	1302-16-0712-00
	3/4"	2"	3/8" CR	1302-17-0712-00
	3/4"	3"	3/8" CR	1302-19-0712-00
	3/4"	4"	3/8" CR	1302-21-0712-00
3/4" IPS Socket Weld	3/4"	3/4"	3/8" CR	1302-13-0713-00
	3/4"	1"	3/8" CR	1302-14-0713-00
	3/4"	1 1/4"	3/8" CR	1302-15-0713-00
	3/4"	1 1/2"	3/8" CR	1302-16-0713-00
	3/4"	2"	3/8" CR	1302-17-0713-00
	3/4"	3"	3/8" CR	1302-19-0713-00
	3/4"	4"	3/8" CR	1302-21-0713-00
3/4" IPS Plain for Butt Welding	3/4"	3/4"	3/8" CR	1302-13-0813-00
	3/4"	1"	3/8" CR	1302-14-0813-00
	3/4"	1 1/4"	3/8" CR	1302-15-0813-00
	3/4"	1 1/2"	3/8" CR	1302-16-0813-00
	3/4"	2"	3/8" CR	1302-17-0813-00
	3/4"	3"	3/8" CR	1302-19-0813-00
	3/4"	4"	3/8" CR	1302-21-0813-00
1" IPS Plain for Butt Welding	3/4"	1 1/4"	3/8" CR	1302-15-0814-00
	3/4"	1 1/2"	3/8" CR	1302-16-0814-00
	3/4"	2"	3/8" CR	1302-17-0814-00
	3/4"	3"	3/8" CR	1302-19-0814-00
	3/4"	4"	3/8" CR	1302-21-0814-00
	3/4"	6"	3/8" CR	1302-24-0814-00



- For sizes not listed, contact Continental Industries.
- Weld Outlet Saddle Tees rated at 300 psig.
- For optional punch sizes, see page 20.
- Recommended accessories;
 - 23-3691-00 ~ 5/16" Hex Drive Key, Bushing and Socket Adapter for 1201 Style Tees (pg 21)
 - 23-3692-00 ~ 3/8" Hex Drive Key, Bushing and Socket Adapter for 1302 Style Tees (pg 21)
 - 23-1644-00 ~ Test Plug Adapter for 1201 Style Tees (pg 21)
 - 23-1645-00 ~ Test Plug Adapter for 1302 Style Tees (pg 21)
- For additional Accessories, see page 21.

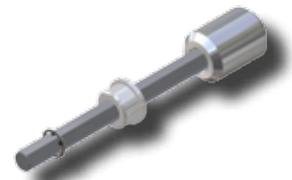

23-3691-00 & 23-3692-00
Hex Drive Key, Bushing and Socket Adapter
for 1201 & 1302 Style Tees (pg 21)

SADDLE PUNCH TEES



1201 & 1302 STYLE STEEL SERVICE SADDLE PUNCH TEES Threaded Outlets

OUTLET	Body Size	IPS Main Size	PUNCH SIZE	PART NUMBER
1/2" IPS Male Pipe Thread	1/2"	3/4"	3/8" CR	1201-13-0912-00
	1/2"	1"	3/8" CR	1201-14-0912-00
	1/2"	1 1/4"	3/8" CR	1201-15-0912-00
	1/2"	1 1/2"	3/8" CR	1201-16-0912-00
	1/2"	2"	3/8" CR	1201-17-0912-00
	1/2"	3"	3/8" CR	1201-19-0912-00
	1/2"	4"	3/8" CR	1201-21-0912-00
3/4" IPS Male Pipe Thread	3/4"	3/4"	3/8" CR	1302-13-0913-00
	3/4"	1"	3/8" CR	1302-14-0913-00
	3/4"	1 1/4"	3/8" CR	1302-15-0913-00
	3/4"	1 1/2"	3/8" CR	1302-16-0913-00
	3/4"	2"	3/8" CR	1302-17-0913-00
	3/4"	3"	3/8" CR	1302-19-0913-00
	3/4"	4"	3/8" CR	1302-21-0913-00
1/2" IPS Female Pipe Thread	1/2"	3/4"	3/8" CR	1201-13-1512-00
	1/2"	1"	3/8" CR	1201-14-1512-00
	1/2"	1 1/4"	3/8" CR	1201-15-1512-00
	1/2"	1 1/2"	3/8" CR	1201-16-1512-00
	1/2"	2"	3/8" CR	1201-17-1512-00
	1/2"	3"	3/8" CR	1201-19-1512-00
	1/2"	4"	3/8" CR	1201-21-1512-00
3/4" IPS Female Pipe Thread	3/4"	3/4"	3/8" CR	1302-13-1513-00
	3/4"	1"	3/8" CR	1302-14-1513-00
	3/4"	1 1/4"	3/8" CR	1302-15-1513-00
	3/4"	1 1/2"	3/8" CR	1302-16-1513-00
	3/4"	2"	3/8" CR	1302-17-1513-00
	3/4"	3"	3/8" CR	1302-19-1513-00
	3/4"	4"	3/8" CR	1302-21-1513-00
3/4"	6"	3/8" CR	1302-24-1513-00	

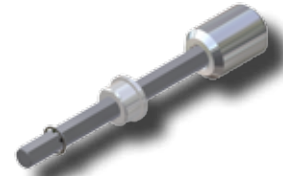

23-3691-00 & 23-3692-00
Hex Drive Key, Bushing and Socket Adapter
for 1201 & 1302 Style Tees (pg 21)

- For sizes not listed, contact Continental Industries.
- Threaded Outlet Saddle Tees rated at 300 psig.
- For optional punch sizes, see page 20.
- Recommended accessories;
 - 23-3691-00 ~ 5/16" Hex Drive Key, Bushing and Socket Adapter for 1201 Style Tees (pg 21)
 - 23-3692-00 ~ 3/8" Hex Drive Key, Bushing and Socket Adapter for 1302 Style Tees (pg 21)
 - 23-1644-00 ~ Test Plug Adapter for 1201 Style Tees (pg 21)
 - 23-1645-00 ~ Test Plug Adapter for 1302 Style Tees (pg 21)
- For additional Accessories, see page 21.



SADDLE PUNCH TEES

STEEL SERVICE SADDLE PUNCH TEES WITH PIPE CAP

The Most Foolproof, Versatile, Economical Punch Tee Available!

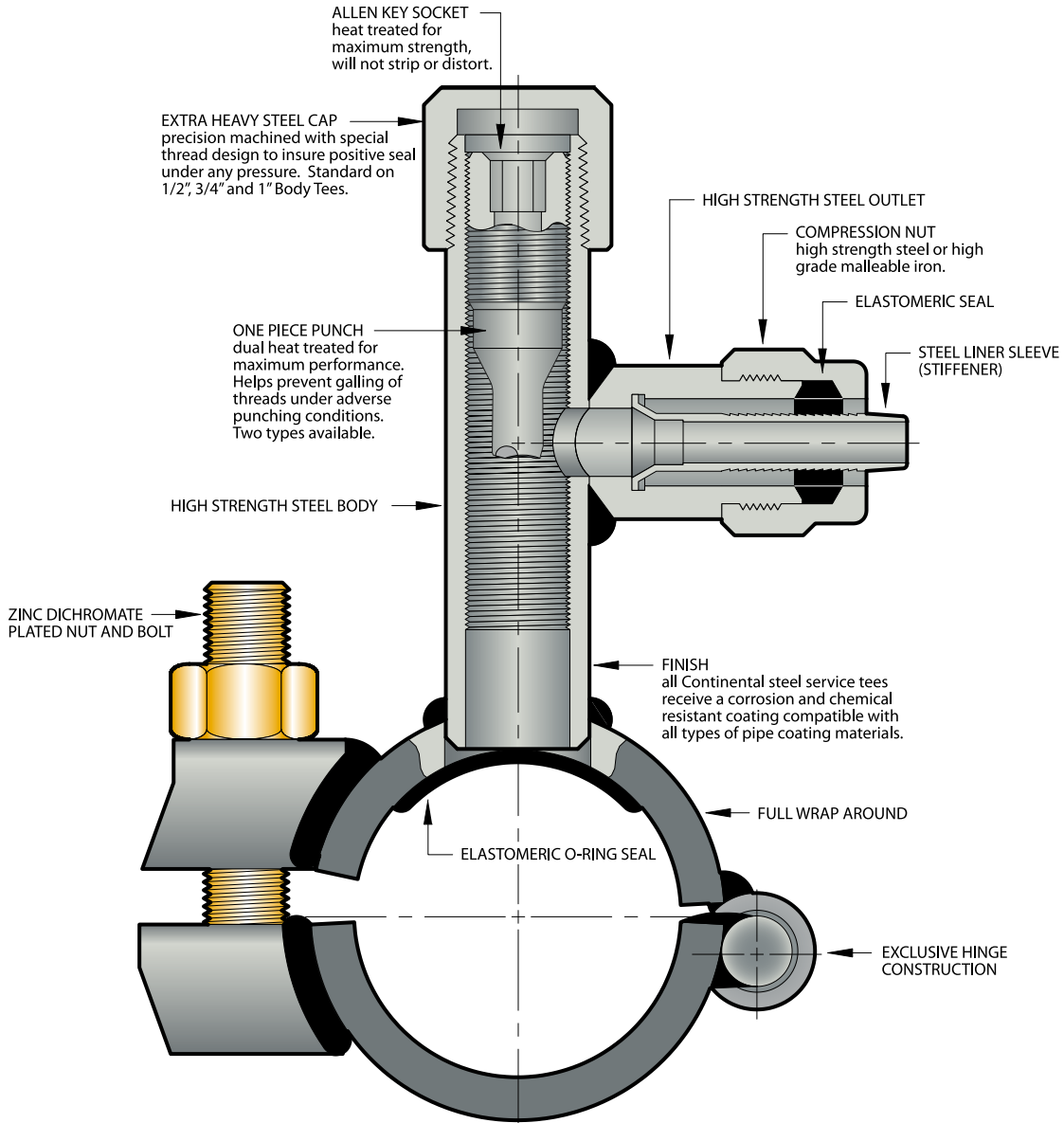

- SAME GREAT FEATURES FOUND ON THE PIPE CAP STYLE PUNCH TEES (SEE PAGE 6)
- PLUS** THE SADDLE PROVIDES;
 - RUGGED ALL STEEL CONSTRUCTION
 - FULL WRAP AROUND
 - ELASTOMERIC O-RING SEAL
 - EXCLUSIVE HINGE CONSTRUCTION
 - USES SINGLE ZINC DICHROMATE PLATED NUT AND BOLT
 - CAN BE USED FOR KEY HOLE APPLICATIONS

NOTE: STANDARD SADDLES TEES ARE FURNISHED WITH OUTLET PERPENDICULAR TO THE MAIN. CONTACT CONTINENTAL FOR OUTLETS PARALLEL TO THE MAIN.



SADDLE PUNCH TEES



1214, 1315, 1416 & 1517 STYLE STEEL SERVICE SADDLE PUNCH TEES PE Compression Outlets

OUTLET	WALL	Body Size	IPS Main Size	PUNCH SIZE	PART NUMBER	
1/2" CTS (5/8" OD)	.090	1/2"	3/4"	3/8" CR	1214-13-1004-00	
		3/4"			1315-13-1004-00	
		1/2"	1"	3/8" CR	1214-14-1004-00	
		3/4"			1315-14-1004-00	
		1/2"	1 1/4"	3/8" CR	1214-15-1004-00	
		3/4"			1315-15-1004-00	
		1/2"	1 1/2"	3/8" CR	1214-16-1004-00	
		3/4"			1315-16-1004-00	
		1/2"	2"	3/8" CR	1214-17-1004-00	
		3/4"			1315-17-1004-00	
		1/2"	3"	3/8" CR	1214-19-1004-00	
		3/4"			1315-19-1004-00	
1/2"	4"	3/8" CR	1214-21-1004-00			
3/4"			1315-21-1004-00			
1/2"	6"	3/8" CR	1214-24-1004-00			
3/4"			1315-24-1004-00			
1" CTS (1 1/8" OD)	.099/.101	3/4"	3/4"	3/8" CR	1315-13-1008-00	
		3/4"	1"	3/8" CR	1315-14-1008-00	
		3/4"	1 1/4"	3/8" CR	1315-15-1008-00	
		1"		3/4" CR	1416-15-1008-00	
		3/4"	1 1/2"	3/8" CR	1315-16-1008-00	
		1"		3/4" CR	1416-16-1008-00	
		3/4"	2"	3/8" CR	1315-17-1008-00	
		1"		3/4" CR	1416-17-1008-00	
		3/4"	3"	3/8" CR	1315-19-1008-00	
		1"		3/4" CR	1416-19-1008-00	
		3/4"	4"	3/8" CR	1315-21-1008-00	
		1"		3/4" CR	1416-21-1008-00	
	3/4"	6"	3/8" CR	1315-24-1008-00		
	1"		3/4" CR	1416-24-1008-00		
	.090	.090	3/4"	3/4"	3/8" CR	1315-13-1008-0A
			3/4"	1"	3/8" CR	1315-14-1008-0A
			3/4"	1 1/4"	3/8" CR	1315-15-1008-0A
			1"		3/4" CR	1416-15-1008-0A
			3/4"	1 1/2"	3/8" CR	1315-16-1008-0A
			1"		3/4" CR	1416-16-1008-0A
3/4"			2"	3/8" CR	1315-17-1008-0A	
1"				3/4" CR	1416-17-1008-0A	
3/4"			3"	3/8" CR	1315-19-1008-0A	
1"				3/4" CR	1416-19-1008-0A	
3/4"			4"	3/8" CR	1315-21-1008-0A	
1"				3/4" CR	1416-21-1008-0A	
3/4"			6"	3/8" CR	1315-24-1008-0A	
1"				3/4" CR	1416-24-1008-0A	

OUTLET	WALL	Body Size	IPS Main Size	PUNCH SIZE	PART NUMBER
1/2" IPS	SDR-9.33 (.090)	1/2"	3/4"	3/8" CR	1214-13-1012-00
		3/4"			1315-13-1012-00
		1/2"	1"	3/8" CR	1214-14-1012-00
		3/4"			1315-14-1012-00
		1/2"	1 1/4"	3/8" CR	1214-15-1012-00
		3/4"			1315-15-1012-00
		1/2"	1 1/2"	3/8" CR	1214-16-1012-00
		3/4"			1315-16-1012-00
		1/2"	2"	3/8" CR	1214-17-1012-00
		3/4"			1315-17-1012-00
		1/2"	3"	3/8" CR	1214-19-1012-00
		3/4"			1315-19-1012-00
1/2"	4"	3/8" CR	1214-21-1012-00		
3/4"			1315-21-1012-00		
1/2"	6"	3/8" CR	1214-24-1012-00		
3/4"			1315-24-1012-00		
3/4" IPS	SDR-11 (.095)	3/4"	3/4"	3/8" CR	1315-13-1013-00
		3/4"	1"	3/8" CR	1315-14-1013-00
		3/4"	1 1/4"	3/8" CR	1315-15-1013-00
		1"		3/4" CR	1416-15-1013-00
		3/4"	1 1/2"	3/8" CR	1315-16-1013-00
		1"		3/4" CR	1416-16-1013-00
		3/4"	2"	3/8" CR	1315-17-1013-00
		1"		3/4" CR	1416-17-1013-00
		3/4"	3"	3/8" CR	1315-19-1013-00
		1"		3/4" CR	1416-19-1013-00
		3/4"	4"	3/8" CR	1315-21-1013-00
		1"		3/4" CR	1416-21-1013-00
3/4"	6"	3/8" CR	1315-24-1013-00		
1"		3/4" CR	1416-24-1013-00		
1" IPS	SDR-11 (.119)	3/4"	3/4"	3/8" CR	1315-13-1014-00
		3/4"	1"	3/8" CR	1315-14-1014-00
		3/4"	1 1/4"	3/8" CR	1315-15-1014-00
		1"		3/4" CR	1416-15-1014-00
		3/4"	1 1/2"	3/8" CR	1315-16-1014-00
		1"		3/4" CR	1416-16-1014-00
		3/4"	2"	3/8" CR	1315-17-1014-00
		1"		3/4" CR	1416-17-1014-00
		3/4"	3"	3/8" CR	1315-19-1014-00
		1"		3/4" CR	1416-19-1014-00
		3/4"	4"	3/8" CR	1315-21-1014-00
		1"		3/4" CR	1416-21-1014-00
3/4"	6"	3/8" CR	1315-24-1014-00		
1"		3/4" CR	1416-24-1014-00		
1 1/4" IPS	SDR-11 (.151)	1 1/4"	2"	1" CR	1517-17-1015-0A
		1 1/4"	3"	1" CR	1517-19-1015-0A
		1 1/4"	4"	1" CR	1517-21-1015-0A
	SDR-10 (.166)	1 1/4"	6"	1" CR	1517-24-1015-0A
		1 1/4"	2"	1" CR	1517-17-1015-00
		1 1/4"	3"	1" CR	1517-19-1015-00
		1 1/4"	4"	1" CR	1517-21-1015-00
		1 1/4"	6"	1" CR	1517-24-1015-00

- For sizes not listed, contact Continental Industries.
- PE Compression Outlets rated at 125 psig.
- For optional punch sizes, see page 20.
- Recommended accessories;
 - 23-3691-00 ~ 5/16" Hex Drive Key, Bushing and Socket Adapter for 1214 Style Tees (pg 21)
 - 23-3692-00 ~ 3/8" Hex Drive Key, Bushing and Socket Adapter for 1315 Style Tees (pg 21)
 - 23-0941-00 ~ 1/2" Square Drive Key, Bushing and Socket Adapter for 1416 Style Tees (pg 21)
 - 23-0940-00 ~ 1/2" Square Drive Key, Bushing and Socket Adapter for 1517 Style Tees (pg 21)
- For Protective Sleeves, see page 26.
- For additional Accessories, see page 21.



23-3691-00 & 23-3692-00
Hex Drive Key, Bushing and Socket Adapter
for 1214 & 1315 Style Tees (pg 21)



23-0941-00 & 23-0940-00
Hex Drive Key, Bushing and Socket Adapter
for 1416 & 1517 Style Tees (pg 21)





SADDLE PUNCH TEES

1214, 1315, 1416 & 1517 STYLE STEEL SERVICE SADDLE PUNCH TEES Steel Tube or Pipe (Conductive) Compression Outlets

OUTLET	Body Size	IPS Main Size	PUNCH SIZE	PART NUMBER
5/8" OD	1/2"	3/4"	3/8" CR	1214-13-1304-00
	3/4"			1315-13-1304-00
	1/2"	1"	3/8" CR	1214-14-1304-00
	3/4"			1315-14-1304-00
	1/2"	1 1/4"	3/8" CR	1214-15-1304-00
	3/4"			1315-15-1304-00
	1/2"	1 1/2"	3/8" CR	1214-16-1304-00
	3/4"			1315-16-1304-00
	1/2"	2"	3/8" CR	1214-17-1304-00
	3/4"			1315-17-1304-00
	1/2"	3"	3/8" CR	1214-19-1304-00
	3/4"			1315-19-1304-00
	1/2"	4"	3/8" CR	1214-21-1304-00
	3/4"			1315-21-1304-00
1/2"	6"	3/8" CR	1214-24-1304-00	
3/4"			1315-24-1304-00	
3/4" IPS	3/4"	3/4"	3/8" CR	1315-13-0413-00
	3/4"	1"	3/8" CR	1315-14-0413-00
	3/4"	1 1/4"	3/8" CR	1315-15-0413-00
	1"		3/4" CR	1416-15-0413-00
	3/4"	1 1/2"	3/8" CR	1315-16-0413-00
	1"		3/4" CR	1416-16-0413-00
	3/4"	2"	3/8" CR	1315-17-0413-00
	1"		3/4" CR	1416-17-0413-00
	3/4"	3"	3/8" CR	1315-19-0413-00
	1"		3/4" CR	1416-19-0413-00
	3/4"	4"	3/8" CR	1315-21-0413-00
	1"		3/4" CR	1416-21-0413-00
	3/4"	6"	3/8" CR	1315-24-0413-00
	1"		3/4" CR	1416-24-0413-00

OUTLET	Body Size	IPS Main Size	PUNCH SIZE	PART NUMBER
1" IPS	3/4"	1 1/4"	3/8" CR	1315-15-0414-00
	1"		3/4" CR	1416-15-0414-00
	3/4"	1 1/2"	3/8" CR	1315-16-0414-00
	1"		3/4" CR	1416-16-0414-00
	3/4"	2"	3/8" CR	1315-17-0414-00
	1"		3/4" CR	1416-17-0414-00
	3/4"	3"	3/8" CR	1315-19-0414-00
	1"		3/4" CR	1416-19-0414-00
	3/4"	4"	3/8" CR	1315-21-0414-00
	1"		3/4" CR	1416-21-0414-00
3/4"	6"	3/8" CR	1315-24-0414-00	
1"		3/4" CR	1416-24-0414-00	
1 1/4" IPS	1 1/4"	2"	1" CR	1517-17-0415-00
	1 1/4"	3"	1" CR	1517-19-0415-00
	1 1/4"	4"	1" CR	1517-21-0415-00
	1 1/4"	6"	1" CR	1517-24-0415-00



- For sizes not listed, contact Continental Industries.
- Steel Tube or Pipe Compression Outlets rated at 300 psig.
- For optional punch sizes, see page 20.
- Recommended accessories;
 - 23-3691-00 ~ 5/16" Hex Drive Key, Bushing and Socket Adapter for 1214 Style Tees (pg 21)
 - 23-3692-00 ~ 3/8" Hex Drive Key, Bushing and Socket Adapter for 1315 Style Tees (pg 21)
 - 23-0941-00 ~ 1/2" Square Drive Key, Bushing and Socket Adapter for 1416 Style Tees (pg 21)
 - 23-0940-00 ~ 1/2" Square Drive Key, Bushing and Socket Adapter for 1517 Style Tees (pg 21)
- For additional Accessories, see page 21.

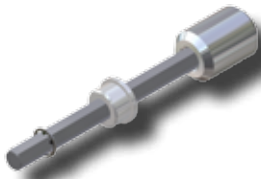

23-3691-00 & 23-3692-00
Hex Drive Key, Bushing and Socket Adapter
for 1214 & 1315 Style Tees (pg 21)



23-0941-00 & 23-0940-00
Hex Drive Key, Bushing and Socket Adapter
for 1416 & 1517 Style Tees (pg 21)

SADDLE PUNCH TEES



1214, 1315, 1416 & 1517 STYLE STEEL SERVICE SADDLE PUNCH TEES Weld Outlets

OUTLET	Body Size	IPS Main Size	PUNCH SIZE	PART NUMBER
1/2" IPS Butt Weld or 3/4" IPS Fillet Weld	1/2"	3/4"	3/8" CR	1214-13-0612-00
	1/2"	1"	3/8" CR	1214-14-0612-00
	1/2"	1 1/4"	3/8" CR	1214-15-0612-00
	1/2"	1 1/2"	3/8" CR	1214-16-0612-00
	1/2"	2"	3/8" CR	1214-17-0612-00
	1/2"	3"	3/8" CR	1214-19-0612-00
	1/2"	4"	3/8" CR	1214-21-0612-00
1/2" IPS Socket Weld	3/4"	3/4"	3/8" CR	1214-24-0612-00
	3/4"	1"	3/8" CR	1315-13-0712-00
	3/4"	1 1/4"	3/8" CR	1315-14-0712-00
	3/4"	1 1/2"	3/8" CR	1315-15-0712-00
	3/4"	2"	3/8" CR	1315-16-0712-00
	3/4"	3"	3/8" CR	1315-17-0712-00
	3/4"	4"	3/8" CR	1315-19-0712-00
3/4" IPS Socket Weld	3/4"	6"	3/8" CR	1315-21-0712-00
	3/4"	3/4"	3/8" CR	1315-24-0712-00
	3/4"	1"	3/8" CR	1315-13-0713-00
	3/4"	1 1/4"	3/8" CR	1315-14-0713-00
	3/4"	1 1/2"	3/8" CR	1315-15-0713-00
	3/4"	2"	3/8" CR	1315-16-0713-00
	3/4"	3"	3/8" CR	1315-17-0713-00
3/4" IPS Plain for Butt Welding	3/4"	4"	3/8" CR	1315-19-0713-00
	3/4"	6"	3/8" CR	1315-21-0713-00
	3/4"	1 1/4"	3/8" CR	1315-24-0713-00
	1"	1 1/4"	3/4" CR	1315-15-0813-00
	3/4"	1"	3/8" CR	1315-16-0813-00
	1"	1 1/2"	3/4" CR	1315-17-0813-00
	3/4"	1"	3/8" CR	1315-18-0813-00
	1"	2"	3/4" CR	1315-19-0813-00
	3/4"	3"	3/8" CR	1315-20-0813-00
1"	4"	3/4" CR	1315-21-0813-00	
3/4"	6"	3/8" CR	1315-22-0813-00	
1"	6"	3/4" CR	1315-23-0813-00	

OUTLET	Body Size	Main Size	PUNCH SIZE	PART NUMBER
1" IPS Plain for Butt Welding	3/4"	1 1/4"	3/8" CR	1315-15-0814-00
	1"	1 1/4"	3/4" CR	1416-15-0814-00
	3/4"	1 1/2"	3/8" CR	1315-16-0814-00
	1"	1 1/2"	3/4" CR	1416-16-0814-00
	3/4"	2"	3/8" CR	1315-17-0814-00
	1"	2"	3/4" CR	1416-17-0814-00
	3/4"	3"	3/8" CR	1315-18-0814-00
	1"	3"	3/4" CR	1416-18-0814-00
	3/4"	4"	3/8" CR	1315-19-0814-00
	1"	4"	3/4" CR	1416-19-0814-00
1 1/4" IPS Plain for Butt Welding	3/4"	6"	3/8" CR	1315-24-0814-00
	1 1/4"	2"	1" CR	1517-17-0815-00
	1 1/4"	3"	1" CR	1517-19-0815-00
	1 1/4"	4"	1" CR	1517-21-0815-00
2" IPS Plain for Butt Welding	1 1/4"	6"	1" CR	1517-24-0815-00
	1 1/4"	2"	1" CR	1517-17-0817-00
	1 1/4"	3"	1" CR	1517-19-0817-00
	1 1/4"	4"	1" CR	1517-21-0817-00
1 1/4"	6"	1" CR	1517-24-0817-00	

- For sizes not listed, contact Continental Industries.
- Weld Outlets Saddle Tees rated at 300 psig.
- For optional punch sizes, see page 20.
- Recommended accessories;
 - 23-3691-00 ~ 5/16" Hex Drive Key, Bushing and Socket Adapter for 1214 Style Tees (pg 21)
 - 23-3692-00 ~ 3/8" Hex Drive Key, Bushing and Socket Adapter for 1315 Style Tees (pg 21)
 - 23-0941-00 ~ 1/2" Square Drive Key, Bushing and Socket Adapter for 1416 Style Tees (pg 21)
 - 23-0940-00 ~ 1/2" Square Drive Key, Bushing and Socket Adapter for 1517 Style Tees (pg 21)
- For additional Accessories, see page 21.

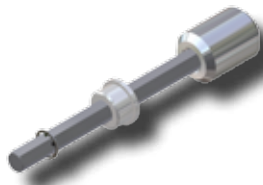

23-3691-00 & 23-3692-00
Hex Drive Key, Bushing and Socket Adapter
for 1214 & 1315 Style Tees (pg 21)



23-0941-00 & 23-0940-00
Hex Drive Key, Bushing and Socket Adapter
for 1416 & 1517 Style Tees (pg 21)



For Outlets Welded Parallel to Main,
Contact Continental Industries



SADDLE PUNCH TEES

1214, 1315, 1416 & 1517 STYLE STEEL SERVICE SADDLE PUNCH TEES Threaded Outlets

OUTLET	Body Size	IPS Main Size	PUNCH SIZE	PART NUMBER
1/2" IPS Male Pipe Thread	1/2"	3/4"	3/8" CR	1214-13-0912-00
	1/2"	1"	3/8" CR	1214-14-0912-00
	1/2"	1 1/4"	3/8" CR	1214-15-0912-00
	1/2"	1 1/2"	3/8" CR	1214-16-0912-00
	1/2"	2"	3/8" CR	1214-17-0912-00
	1/2"	3"	3/8" CR	1214-19-0912-00
	1/2"	4"	3/8" CR	1214-21-0912-00
3/4" IPS Male Pipe Thread	3/4"	3/4"	3/8" CR	1315-13-0913-00
	3/4"	1"	3/8" CR	1315-14-0913-00
	3/4"	1 1/4"	3/8" CR	1315-15-0913-00
	3/4"	1 1/2"	3/8" CR	1315-16-0913-00
	3/4"	2"	3/8" CR	1315-17-0913-00
	3/4"	3"	3/8" CR	1315-19-0913-00
	3/4"	4"	3/8" CR	1315-21-0913-00
1" IPS Male Pipe Thread	3/4"	1 1/4"	3/8" CR	1315-15-0914-00
	3/4"	1 1/2"	3/8" CR	1315-16-0914-00
	3/4"	2"	3/8" CR	1315-17-0914-00
	3/4"	3"	3/8" CR	1315-19-0914-00
	3/4"	4"	3/8" CR	1315-21-0914-00
3/4" IPS Female Pipe Thread	3/4"	6"	3/8" CR	1315-24-0913-00
	3/4"	1 1/4"	3/8" CR	1315-15-1513-00
	3/4"	1 1/2"	3/8" CR	1315-16-1513-00
	3/4"	2"	3/8" CR	1315-17-1513-00
	3/4"	3"	3/8" CR	1315-19-1513-00
	3/4"	4"	3/8" CR	1315-21-1513-00
1" IPS Female Pipe Thread	3/4"	6"	3/8" CR	1315-24-1513-00
	1"	1 1/4"	3/4" CR	1416-15-1514-00
	1"	1 1/2"	3/4" CR	1416-16-1514-00
	1"	2"	3/4" CR	1416-17-1514-00
	1"	3"	3/4" CR	1416-19-1514-00
	1"	4"	3/4" CR	1416-21-1514-00
1 1/4" IPS Female Pipe Thread	1"	6"	3/4" CR	1416-24-1514-00
	1 1/4"	2"	1" CR	1517-17-1515-00
	1 1/4"	3"	1" CR	1517-19-1515-00
	1 1/4"	4"	1" CR	1517-21-1515-00
	1 1/4"	6"	1" CR	1517-24-1515-00



- For sizes not listed, contact Continental Industries.
- Threaded Outlets Saddle Tees rated at 300 psig.
- For optional punch sizes, see page 20.
- Recommended accessories;
 - 23-3691-00 ~ 5/16" Hex Drive Key, Bushing and Socket Adapter for 1214 Style Tees (pg 21)
 - 23-3692-00 ~ 3/8" Hex Drive Key, Bushing and Socket Adapter for 1315 Style Tees (pg 21)
 - 23-0941-00 ~ 1/2" Square Drive Key, Bushing and Socket Adapter for 1416 Style Tees (pg 21)
 - 23-0940-00 ~ 1/2" Square Drive Key, Bushing and Socket Adapter for 1517 Style Tees (pg 21)
- For additional Accessories, see page 21.

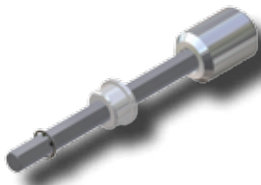

23-3691-00 & 23-3692-00
Hex Drive Key, Bushing and Socket Adapter
for 1214 & 1315 Style Tees (pg 21)



23-0941-00 & 23-0940-00
Hex Drive Key, Bushing and Socket Adapter
for 1416 & 1517 Style Tees (pg 21)

TECHNICAL INFO



PUNCH DATA — SIZES, TYPES & WALL LIMITS for Steel Punch Tees

“CR” Coupon Retaining Punch

Coupon is actually retained in head of punch
– no more coupons left inside mains.
Exclusive tip design reduces tapping torque.
Available with all Continental Punch Tees.

EXCLUSIVE

“NC” No Coupon Punch

No “Coupon” Punch flares a hole
in the main without producing a “Coupon”.
Available in 1/4" & 3/8" sizes only.
Specify “No Coupon Punch”.



- One piece tool steel
- Positive valve
- Socket and threads heat treated for maximum toughness
- Cutting tip is heat treated for maximum hardness



TEE BODY SIZE	PUNCH TIP SIZE	NC CAT. NO.	CR CAT. NO.	DRIVE KEY SIZE	DRIVE KEY CATALOG NO.	MAX. WALL THICKNESS	MAX. PIPE YIELD STRENGTH
1/2" BODY PUNCHES							
1/2" Body Tee	1/4"	06-0442-00	N/A	5/16" Hex	23-3691-00	0.25	65 ksi
1/2" Body Tee	3/8"	N/A	06-0895-00†	5/16" Hex	23-3691-00	0.28	70 ksi
3/4" BODY PUNCHES							
3/4" Body Tee	3/8"	06-5961-00	06-0478-00†	3/8" Hex	23-3692-00	0.28	70 ksi
3/4" Body Tee	1/2"	N/A	06-0452-00	3/8" Hex	23-3692-00	0.25	65 ksi
1" BODY PUNCHES							
1" Body Tee	3/8"	N/A	06-3687-00	1/2" Sq.	23-0941-00	0.28	70 ksi
1" Body Tee	3/4"	N/A	06-0832-00†	1/2" Sq.	23-0941-00	0.25	65 ksi
1 1/4" BODY PUNCHES							
1 1/4" Body Tee	1"	N/A	06-0767-00†	1/2" Sq.	23-0940-0	0.25	65 ksi

† Standard

Lubricant must be applied to the punch threads and punch tip. Acceptable lubricants include thread cutting oil, tapping fluid or tapping grease.



ACCESSORIES FOR STEEL PUNCH TEES

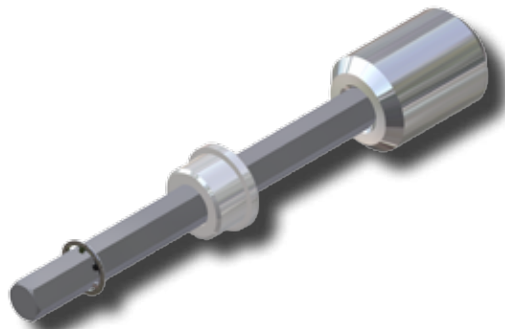

23-3691-00 ~ Drive Key Assembly for 1/2" Body Punch Tees
 23-3692-00 ~ Drive Key Assembly for 3/4" Body Punch Tees



23-0941-00 ~ Drive Key Assembly for 1" Body Punch Tees
 23-0940-00 ~ Drive Key Assembly for 1 1/4" Body Punch Tees



23-1644-00 ~ Test Plug Adapter for 1201 Style 1/2" Body Punch Tees
 23-1645-00 ~ Test Plug Adapter for 1302 Style 3/4" Body Punch Tees

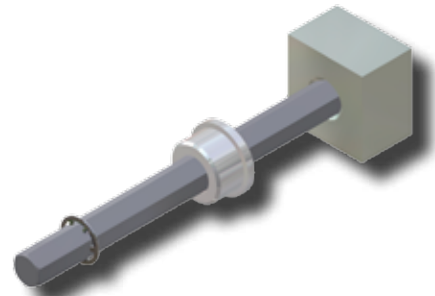

23-0553-01 ~ 5/16" HEX DRIVE KEY, BUSHING AND ADAPTER
 23-0553-00 ~ 3/8" HEX DRIVE KEY, BUSHING AND ADAPTER

CATALOG NO.	DESCRIPTION
DRIVE KEYS TO BE USED WITH 1/2" BODY PUNCH TEE STYLES: 1201 & 1214	
0000-23-3691-00	5/16" HEX DRIVE KEY, BUSHING AND SOCKET ADAPTER
0000-23-1018-00	REPLACEMENT 5/16" HEX DRIVE KEY FOR 0000-23-3691-00
0000-23-1019-00	REPLACEMENT BUSHING FOR 0000-23-3691-00
0000-23-1020-00	REPLACEMENT SOCKET ADAPTER FOR 0000-23-3691-00
0000-23-1021-00	5/16" HEX DRIVE KEY AND BUSHING ONLY
0000-23-0553-01	5/16" HEX DRIVE KEY, BUSHING AND ADAPTER FOR USE WITH DRESSER'S® 1 1/8" SQUARE RATCHET WRENCH
DRIVE KEYS TO BE USED WITH 3/4" BODY PUNCH TEE STYLES 1302 & 1315	
0000-23-3692-00	3/8" HEX DRIVE KEY, BUSHING AND SOCKET ADAPTER
0000-23-0544-00	REPLACEMENT 3/8" HEX DRIVE KEY FOR 0000-23-3692-00
0000-23-0543-00	REPLACEMENT BUSHING FOR 0000-23-3692-00
0000-23-0542-00	REPLACEMENT SOCKET ADAPTER FOR 0000-23-3692-00
0000-23-0481-00	3/8" HEX DRIVE KEY AND BUSHING ONLY
0000-23-0553-00	3/8" HEX DRIVE KEY, BUSHING AND ADAPTER FOR USE WITH DRESSER'S® 1 1/8" SQUARE RATCHET WRENCH
DRIVE KEYS TO BE USED WITH 1" BODY PUNCH TEE STYLE 1416	
0000-23-0941-00	1/2" SQUARE DRIVE KEY, BUSHING AND SOCKET ADAPTER
0000-23-7236-00	REPLACEMENT 1/2" SQUARE DRIVE KEY FOR 0000-23-0941-00
0000-23-0882-01	REPLACEMENT BUSHING FOR 0000-23-0941-00
DRIVE KEYS TO BE USED WITH 1 1/4" BODY PUNCH TEE STYLE 1517	
0000-23-0940-00	1/2" SQUARE DRIVE KEY, BUSHING AND SOCKET ADAPTER
0000-23-7236-00	REPLACEMENT 1/2" SQUARE DRIVE KEY FOR 0000-23-0940-00
0000-23-0883-01	REPLACEMENT BUSHING FOR 0000-23-0940-00
OTHER ACCESSORIES	
0000-23-1644-00	TEST PLUG ADAPTER FOR 1201 STYLE PUNCH TEES
0000-23-1645-00	TEST PLUG ADAPTER FOR 1302 STYLE PUNCH TEES
0000-08-1554-03	REPLACEMENT O-RING FOR 0000-23-1644-00 TEST PLUG ADAPTER
0000-08-1554-04	REPLACEMENT O-RING FOR 0000-23-1645-00 TEST PLUG ADAPTER

SAFE-T VALVE TEES



STEEL SERVICE SAFE-T VALVE TEES WITH PIPE CAP

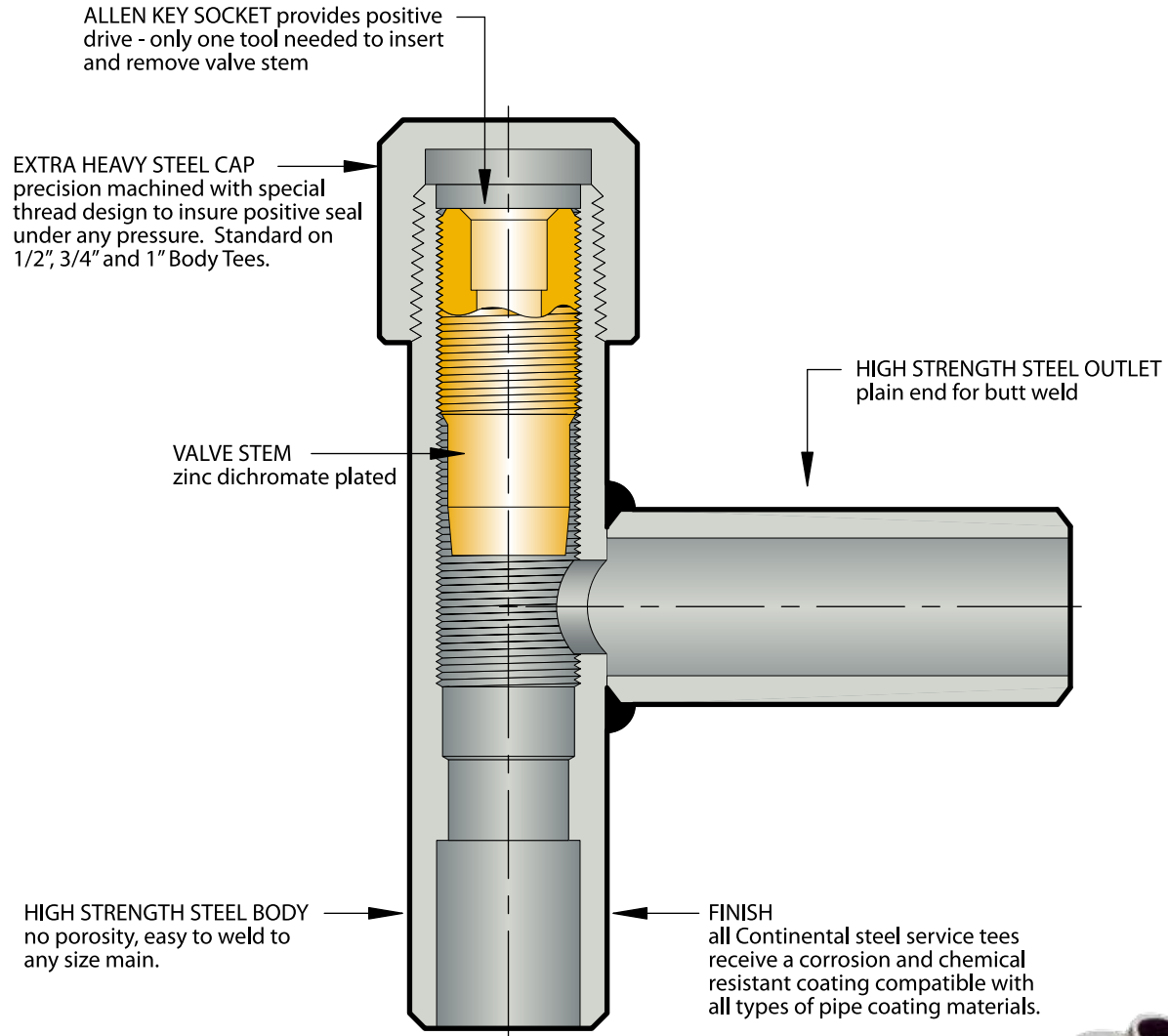

- A VALVE TEE FOR THE COST OF MOST PLAIN TEES
- EASILY INSTALLED WITH ANY STANDARD DRILLING MACHINE
- WELDS ARE TESTED TO 800 PSI
- CAN BE FURNISHED WITH ANY TYPE CONTINENTAL OUTLET
- AVAILABLE IN WELD OR THREADED INLETS





SAFE-T VALVE TEES

1319, 1420 & 1521 STYLE STEEL SERVICE SAFE-T VALVE TEES PE Compression Outlets

OUTLET	WALL	INLET	PART NUMBER
1/2" CTS (5/8" OD)	.090	3/4" Weld	1319-10-1004-00
		3/4" Threaded	1319-11-1004-00
		1" Weld	1420-10-1004-00
	.062	1" Threaded	1420-11-1004-00
		3/4" Weld	1319-10-1004-0A
		3/4" Threaded	1319-11-1004-0A
1" CTS (1 1/8" OD)	.099/.101	1" Weld	1420-10-1004-0A
		1" Threaded	1420-11-1004-0A
		3/4" Weld	1319-10-1008-00
	.090	3/4" Threaded	1319-11-1008-00
		1" Weld	1420-10-1008-00
		1" Threaded	1420-11-1008-00
1/2" IPS	SDR-9.33 (.090)	3/4" Weld	1319-10-1008-0A
		3/4" Threaded	1319-11-1008-0A
		1" Weld	1420-10-1008-0A
		1" Threaded	1420-11-1008-0A
3/4" IPS	SDR-11 (.095)	3/4" Weld	1319-10-1012-00
		3/4" Threaded	1319-11-1012-00
		1" Weld	1420-10-1012-00
		1" Threaded	1420-11-1012-00
1" IPS	SDR-11 (.119)	1" Weld	1319-10-1013-00
		1" Threaded	1319-11-1013-00
1 1/4" IPS	SDR-11 (.151)	1 1/4" Weld	1420-10-1014-00
		1 1/4" Threaded	1420-11-1014-00
	SDR-10 (.166)	1 1/4" Weld	1521-10-1015-0A
		1 1/4" Threaded	1521-11-1015-0A



- For sizes not listed, contact Continental Industries.
- PE Compression Outlets rated at 125 psig.
- Recommended accessories;
 - 23-0549-00 ~ Adapter and Key for H-17045 Completion Machine (pg 25)
- For Protective Sleeves, see page 26.
- For additional Accessories, see page 25.

1319, 1420 & 1521 STYLE STEEL SERVICE SAFE-T VALVE TEES Steel Tube or Pipe (Conductive) Compression Outlets

OUTLET	INLET	PART NUMBER
5/8" OD	3/4" Weld	1319-10-1304-00
	3/4" Threaded	1319-11-1304-00
3/4" IPS	3/4" Weld	1319-10-0413-00
	3/4" Threaded	1319-11-0413-00
1" IPS	1" Weld	1420-10-0414-00
	1" Threaded	1420-11-0414-00
1 1/4" IPS	1 1/4" Weld	1521-10-0415-00
	1 1/4" Threaded	1521-11-0415-00



- For sizes not listed, contact Continental Industries.
- Steel Tube or Pipe Compression Outlets rated at 300 psig.
- Recommended accessories;
 - 23-0549-00 ~ Adapter and Key for H-17045 Completion Machine (pg 25)
- For additional Accessories, see page 25.

SAFE-T VALVE TEES



1319, 1420 & 1521 STYLE STEEL SERVICE SAFE-T VALVE TEES Weld Outlets

OUTLET	INLET	PART NUMBER
3/4" IPS Socket Weld	3/4" Weld	1319-10-0713-00
	3/4" Threaded	1319-11-0713-00
3/4" IPS Plain for Butt Welding	3/4" Weld	1319-10-0813-00
	3/4" Threaded	1319-11-0813-00
1" IPS Plain for Butt Welding	1" Weld	1420-10-0814-00
	1" Threaded	1420-11-0814-00
1 1/4" IPS Plain for Butt Welding	1 1/4" Weld	1521-10-0815-00
	1 1/4" Threaded	1521-11-0815-00

- **For sizes not listed, contact Continental Industries.**
- Weld Outlet Saddle Tees rated at 300 psig.
- Recommended accessories;
 - 23-0549-00 ~ Adapter and Key for H-17045 Completion Machine (pg 25)
- For additional Accessories, see page 25.



1319, 1420 & 1521 STYLE STEEL SERVICE SAFE-T VALVE TEES Threaded Outlets

OUTLET	INLET	PART NUMBER
3/4" IPS Male Pipe Thread	3/4" Weld	1319-10-0913-00
	3/4" Threaded	1319-11-0913-00
1" IPS Male Pipe Thread	1" Weld	1420-10-0914-00
	1" Threaded	1420-11-0914-00
1 1/4" IPS Male Pipe Thread	1 1/4" Weld	1521-10-0915-00
	1 1/4" Threaded	1521-11-0915-00
3/4" IPS Female Pipe Thread	3/4" Weld	1319-10-1513-00
	3/4" Threaded	1319-11-1513-00
1" IPS Female Pipe Thread	1" Weld	1420-10-1514-00
	1" Threaded	1420-11-1514-00
1 1/4" IPS Female Pipe Thread	1 1/4" Weld	1521-10-1515-00
	1 1/4" Threaded	1521-11-1515-00

- **For sizes not listed, contact Continental Industries.**
- Threaded Outlet Saddle Tees rated at 300 psig.
- Recommended accessories;
 - 23-0549-00 ~ Adapter and Key for H-17045 Completion Machine (pg 25)
- For additional Accessories, see page 25.





ACCESSORIES FOR STEEL VALVE TEES

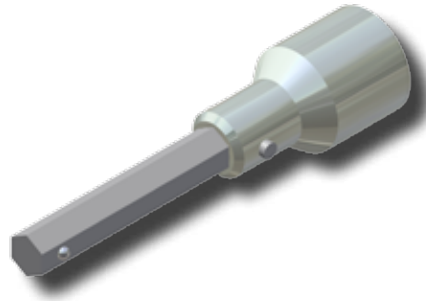

23-0549-00 ~ Adapter & Key Assembly for H-17045 Completion Machine

CATALOG NO.	DESCRIPTION
ADAPTER AND KEY FOR H-17045 COMPLETION MACHINE	
0000-23-0549-00	ADAPTER AND KEY ASSEMBLY FOR H-17045 COMPLETION MACHINE
0000-23-0626-00	ADAPTER ONLY
0000-23-0470-00	3/8" HEX DRIVE KEY
ADAPTER AND KEY FOR USE WITH E4, D4, DH2 AND T DRILLING MACHINES	
0000-23-0674-00	SOCKET ASSEMBLY ONLY
0000-23-0470-00	3/8" HEX DRIVE KEY

TECHNICAL INFO



PE PROTECTIVE SLEEVES



CATALOG NUMBER	DIAMETER		LENGTH	FOR USE WITH CONTINENTAL PRODUCTS			
	INTERNAL	OUTSIDE		STEEL FITTINGS	PVC FITTINGS	PA-11 FITTINGS	STAB FITTINGS
44-2585-00	1.370/1.395	1.612	12"		1/4" OD & 7/8" OD P.E. Compression O/L's		
44-2586-00	1.875/1.915	2.190	12"		3/8" OD & 5/8" OD P.E. Compression O/L's	3/8" OD & 5/8" OD P.E. Compression O/L's	
44-2587-00	2.375/2.425	2.760	12"	3/8" OD, 5/8" OD P.E. Compression O/L's	1 1/8" OD, 1/2" IPS & 3/4" IPS P.E. Compression O/L's	1 1/8" OD P.E. Compression O/L's	
44-2588-00	2.375/2.425	2.760	21"	5/8" OD, 1/2" IPS & 3/4" IPS P.E. Transition O/L's			
44-2589-00	2.875	3.270	24"	7/8" OD, 1/2" IPS P.E. Compression O/L's	1" IPS P.E. Compression O/L's	3/4" IPS & 1" IPS P.E. Compression O/L's	5/8" OD, 7/8" OD, 1 1/8" OD, 1/2" IPS, 3/4" IPS & 1" IPS O/L's
				1 1/8" OD, 1" IPS P.E. Transition O/L's			
44-5753-00	4.250 MIN.	4.760	24"	1 1/8" OD, 3/4" IPS, 1" IPS, 1 1/4" IPS & 1 1/2" IPS P.E. Compression O/L's	1 1/4" IPS P.E. Compression O/L's	1 1/4" IPS P.E. Compression O/L's	1 1/4" IPS & 1 1/2" IPS O/L's
				1 1/4" IPS P.E. Transition O/L's			
44-5754-00	5.200 MIN.	5.820	36"		2" IPS P.E. Compression O/L's	2" IPS P.E. Compression O/L's	2" IPS O/L's

NOTE: It is advisable to limit shear at main connections. In this regard, your company's policies should be followed. For further information, reference; ASTM D 2774 Standard Practice for Underground Installation of Thermoplastic Pressure Piping; Code of Federal Regulations, Title 49, Transportation Part 192; AGA Plastic Pipe Manual and/or The Guidance Manual for Operators of Small Gas Systems by the U.S. Department of Transportation.

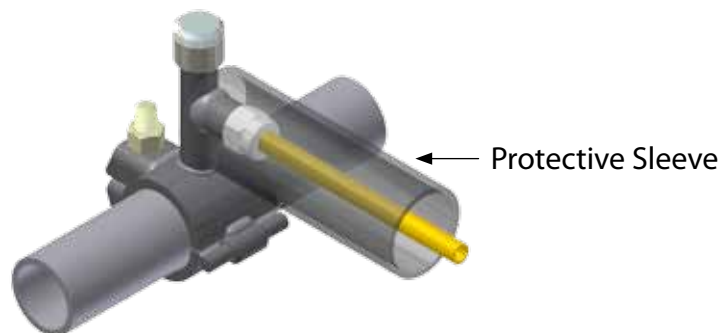



Continental's Steel Punch Tees & Steel Saddle Punch Tees provide the user with the following advantages:

- Cost effective joining method
- Simple assembly
- No bulky drilling equipment required
- Safe - No blowing of gas
- Two types of punches available
- Meets or exceeds all D.O.T. and ASTM requirements
- Can be furnished with any type Continental outlet (compression, Con-Stab ID Seal®, threaded and weld)



Each Saddle provides the following unique features:

- Rugged all steel construction
- Full saddle wraparound
- Elastomeric O ring seal
- Exclusive hinge design
- Uses single zinc dichromate plated SAE J429 Grade 2 nut and bolt

Continental Industries is an ISO 9001 Certified Company. Continental's Steel Punch Tees and Steel Saddle Punch Tees are manufactured and tested to the following industry standards.

- ASTM D 2513 "Standard Specification for Thermoplastic Gas Pressure Pipe, Tubing and Fittings"
- ASME B31.8-1995 "Gas Transmission and Distribution Piping Systems"
- D.O.T., Title 49 of the Code of Federal Regulations, Part 192.283 (b) & 192.367

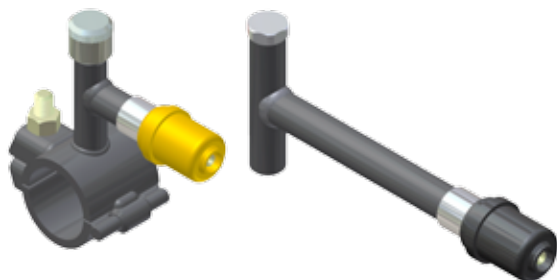

GAS DISTRIBUTION PRODUCTS
CON-STAB ID SEAL®
FITTINGS



For Steel Service Tees with Con-Stab ID Seal® Outlets, see Continental's "Con-Stab ID Seal® Fittings" Catalog



OTHER QUALITY PRODUCTS FROM CONTINENTAL INDUSTRIES

GAS DISTRIBUTION PRODUCTS
**CON-STAB ID SEAL®
FITTINGS**



Con-Stab ID Seal® Fittings

GAS DISTRIBUTION PRODUCTS
STEEL SERVICE TEES



Steel Service Tees

GAS DISTRIBUTION PRODUCTS
**STEEL
COUPLINGS**



Steel Couplings

GAS DISTRIBUTION PRODUCTS
METER RISERS



Meter Risers

GAS DISTRIBUTION PRODUCTS
TRANSITION FITTINGS



Transition Fittings

GAS DISTRIBUTION PRODUCTS
**EFV FITTING
CATALOG**



EFV Catalog

GAS DISTRIBUTION PRODUCTS
**IN-LINE REPAIR
FITTINGS**



FROM STANDARD TO SPECIALS,
CONTINENTAL INDUSTRIES HAS YOUR IN-LINE REPAIR FITTING.
NO OTHER SINGLE MANUFACTURER CAN OFFER THE VARIETY
OF REPAIR FITTINGS THAT
CONTINENTAL INDUSTRIES PROVIDES.



In-Line Repair Fittings

WATER DISTRIBUTION PRODUCTS
PVC WATER FITTINGS



PVC Water Fittings



thermOweld® for
Cathodic Protection



CONTINENTAL INDUSTRIES

1140 North 129th East Ave. Tulsa, Oklahoma 74116

(Phone) 800-558-1373 or 918-627-5210

(Fax) 800-788-1668 or 918-622-1275

www.conind.com

The Ultimate Connection