

Universal Elbowlet

Class 3000 and 6000 Butt weld, Threaded and Socket-Weld

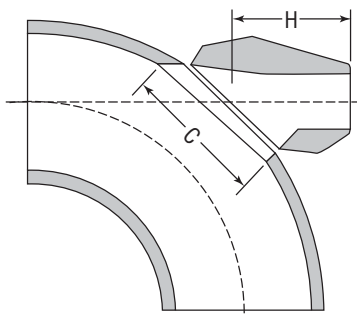

BUTTWELD

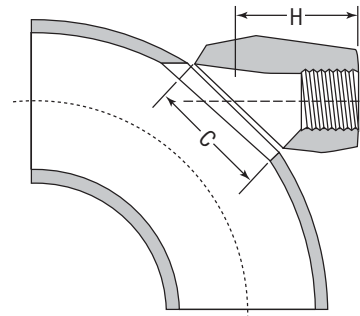

THREADED

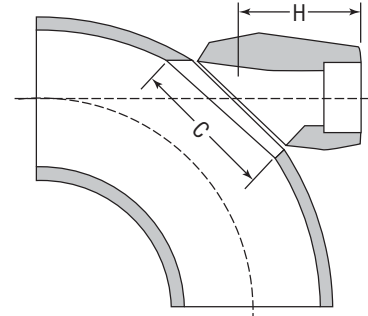

SOCKET-WELD

CLASS 3000 THREADED AND SOCKET-WELD/STANDARD AND XS/XH BUTTWELD

Outlet Size		Nom. Elbow Size		C		H		Unit Weight	
NPS	DN	NPS	DN	in	mm	in	mm	lbs	kg
1/2	15	36 - 3/4	900 - 32	1 1/2	38	1 9/32	40	0.65	0.29
3/4	20	36 - 1	900 - 32	1 23/32	44	1 7/8	48	0.75	0.34
1	25	36 - 2	900 - 32	2 1/8	54	2 3/16	56	1.10	0.52
1 1/4	32	36 - 2	900 - 32	1 21/32	42	2 3/8	60	1.90	0.86
1 1/2	40	36 - 2	900 - 32	3	76	2 5/8	67	2.60	1.20
2	50	36 - 3	900 - 32	4 1/8	105	3 3/16	81	5.30	2.40

CLASS 6000 THREADED AND SOCKET-WELD

1/2	15	36 - 3/4	900 - 32	1 23/32	44	1 7/8	48	0.85	0.39
3/4	20	36 - 1	900 - 50	2 1/8	54	2 3/16	56	1.30	0.57
1	25	36 - 2	900 - 50	2 21/32	67	2 3/8	60	2.20	1.00
1 1/4	32	36 - 2	900 - 50	3	76	2 5/8	67	3.90	1.80
1 1/2	40	36 - 2	900 - 50	4 1/8	105	3 3/16	81	6.20	2.80

Universal elbowlets are welded to 90° long radius elbows as branch connections for pipes and fittings. They are also used as pipe hanger or support bosses.