

Fig. 285

Light Weight Concrete Insert

Size Range: 1/4" through 5/8"

Material: Carbon steel

Finish: Plain or Galvanized

Service: Upper attachment for suspending pipe or conduit from concrete ceiling.

Approvals: Complies with Federal Specification A-A-1192A (Type 18), WW-H-171-E (Type 18), ANSI/MSS SP-69 and MSS SP-58 (Type 19).

UL, ULC Listed (Sizes 3/8" - 5/8") and FM Approved (Sizes 3/8" and 1/2").

Installation:

1. Nail insert to wooden forms.
2. Reinforcing rods may be located under the arched flanges at the top of the insert. However, note that the specified load ratings and approvals are not dependent on the use of any reinforcing rods in contact with the insert.
3. After concrete is poured and wooden forms are removed, remove knockout by tapping along edge with pointed instrument.
4. Slip nut into insert and screw rod through nut until rod is firmly against the top of the insert body.

Features:

- Suitable for use in concrete 2" thick due to low overall height.
- Highly competitive.
- Provides for 2" of lateral adjustment.
- Knockout prevents seepage of concrete from underneath the insert up into the insert body.
- One body size.
- Removable nut in four sizes.
- Rod can be rigidly locked in position.

Ordering: Specify figure number, name, finish and size of nut.

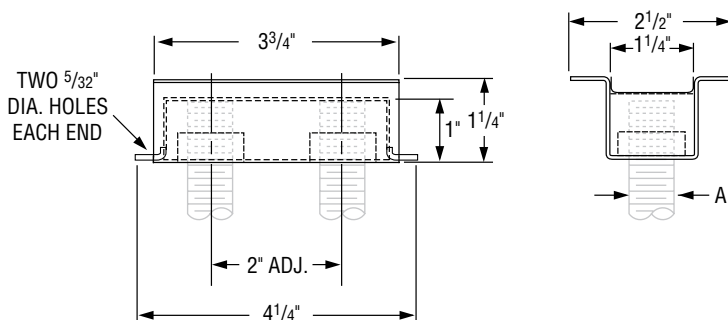

**FIG. 285:
LOAD (LBS) • WEIGHT (LBS) • DIMENSIONS (IN)**

	Rod Size A	Max Load ■	Weight
Insert Complete With Nut	1/4	400	0.46
	3/8		0.49
	1/2		0.49
	5/8		0.48
Insert Only	—	—	0.41
Nut Only	1/4	—	0.07
	3/8	—	
	1/2	—	
	5/8	—	

■ Based on insert and nut only. Rating is subject to the condition that the concrete used is of sufficient strength to hold the insert.