

PIPE ROLL

Figure 67

Our Figure 67 Pipe Roll is used with Figure 17, 39, 40, and 53 adjustable and non-adjustable chairs and rolls, also on various types of hangers and supports

This product is shown for conceptual special assembly design purposes only and is not sold as an individual product.

Material: Cast Iron.

Do not exceed 450° F / 232° C at the contact point to the roll.

Finish: Plain, Painted, Hot-Dip Galvanized.

Ordering: Specify roll size and figure number. For Metric applications specify Figure M67.

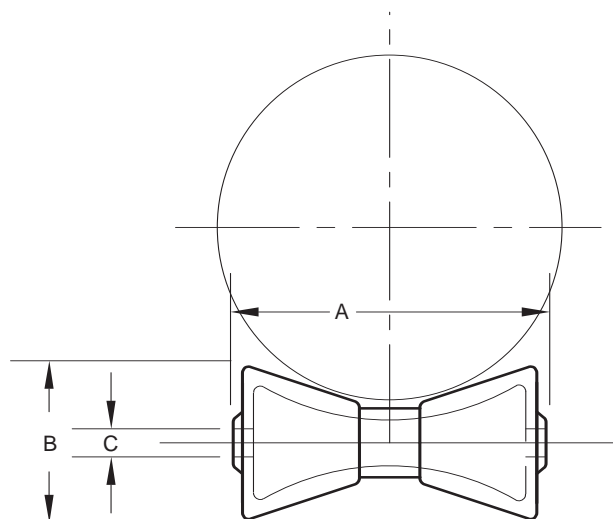

FIGURE 67 – PIPE ROLL

ROLL NO.	PIPE SIZES	A	B	ROD C	WEIGHT EACH
1A	2-3 1/2	2 1/16	1 7/8	1/2	1.02
1A	50 - 80	68	48	M12	0.46
1	4-6	3 3/4	2 1/16	1/2	1.26
1	100 - 150	95	52	M12	0.57
2	8-10	6	3 3/4	3/4	4.42
2	200 - 250	152	83	M20	2.00
3	12-14	8	4	7/8	8.82
3	300 - 350	203	102	M20	4.00
4	16-20	9 5/8	4 1/2	1 1/8	12.2
4	400 - 500	232	114	M30	5.53
5	24	10	4 7/16	1 3/8	14.5
5	600	254	113	M36	6.58
6	30	12 1/2	5 1/2	1 3/4	23.6
6	750	318	140	M42	10.7

DIMENSIONS	TEMPERATURE	LOADS	WEIGHT
INCHES	FAHRENHEIT	POUNDS	POUNDS
MILLIMETERS	CELSIUS	NEWTONS	KILOGRAMS