

INSTALLATION SYSTEMS

Between us, ideas become reality™

DC FLEXZONE™ Suspension System

Electrical Design Guide

System drawings and electrical details with
DC FlexZone Compatible Partners





Low Voltage DC Power Distribution from the Ceiling

DC FlexZone™ is the only ceiling suspension system that provides an infrastructure for the delivery of low voltage direct current (DC) power based on the EMerge Alliance 24 VDC Occupied Space Standard.

DC FlexZone Ceiling Suspension Systems are designed for use with compatible power, infrastructure, lighting, and control products. Compatible products are available from other members of the EMerge Alliance, several of whom are called out here as “DC FlexZone Compatible Partners”.

This booklet describes the role and function of the different compatible product categories and how they relate to the Armstrong DC FlexZone Suspension System.

Please consult the DC FlexZone Compatible Partners listed in this brochure for technical details, specification information, and application guides on their products.

AC Branch Power ▶
DC Renewable Power ▶
(Optional)

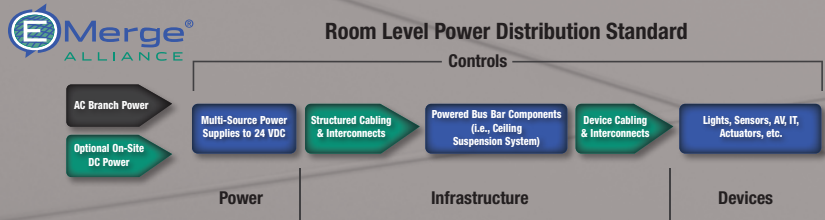

Copyright EMerge Alliance. All rights reserved.

Visit emergealliance.org for more information on their platform of DC power distribution standards.

System / Component Relationships

EMerge Alliance Registered® & Related Product Categories (for Building Applications of EMerge 24VDC Occupied Space Standard)	Specified by Elect. Engineer / Lighting Designer (Div 16/26)	Purchased by Electrical Contractor	Installed by Electrical Contractor	Specified by Architect / Interior Designer (Div 9)	Purchased by Acoustical Contractor	Installed by Acoustical Contractor
9/16" Ceiling Suspension System (Armstrong DC FlexZone™ – Suprafine Exposed Tee or Silhouette 1/4" Slot Reveal)				•	•	•
Acoustical Ceiling Tile (i.e. Armstrong Ultima® 1912HRC)				•	•	•
AC-DC Power Supplies, DC-DC Power Supplies	•	•	•			
Power Feed Cables	•	•	•			
24VDC Lighting Fixtures LED or Fluorescent with Connectors and / or Load Device Cable Assemblies	•	•	•			
24VDC Ballasts or Drivers for Lighting Fixtures	•	•	•			
Controls (Wireless or Wired)	•	•	•			

INFRASTRUCTURE

Structured Cabling & Interconnects ▶

Powered Bus Bar Components
(DC FlexZone Suspension System) ▶

Device Cabling & Interconnects ▶

PERIPHERALS

Lights, Sensors, etc.
▼

CONTROLS

DC FLEXZONE Compatible Partners

POWER ▶

Nextek Power Systems
ROAL Electronics

INFRASTRUCTURE ▶

TE Connectivity

PERIPHERALS ▶

Acuity Brands
Cooper Lighting
Focal Point
JLC tech
Osram Sylvania
Philips Day-Brite
Philips Lightolier

CONTROLS ▶

Acuity Brands
Crestron Electronics
Encelium

AcuityBrands
Expanding the boundaries of lighting™

COOPER Lighting

CRESTRON

FOCAL POINT

OSRAM SYLVANIA

JLC • tech

ENCELIUM

NEXTEK
Power Systems

PHILIPS Day-Brite

PHILIPS LIGHTOLIER

TE
connectivity

ROAL
living energy

DC FLEXZONE™ Suspension System Profiles

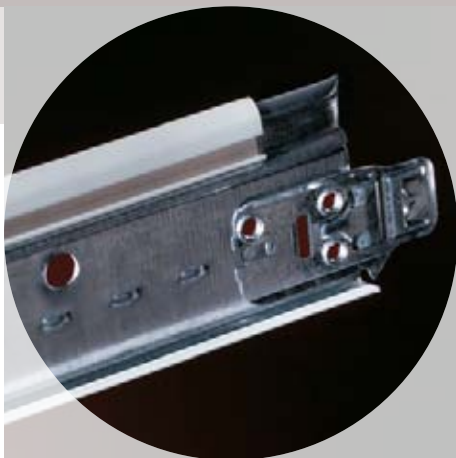

DC FlexZone Suprafine Main Beam
1 set of electrical conductors on suspension system bulb



DC FlexZone Silhouette Main Beam
2 sets of electrical conductors – on suspension system bulb and in bottom reveal

This brochure provides the technical drawings, details, and specification information for DC FlexZone Suspension Systems and how they relate to DC FlexZone Compatible products in power, infrastructure, lighting, and controls.

In this Brochure:

- 3-4 Step 1: Lighting Design
- 5-10 Step 2: Ceiling Suspension System Layout
- 11 Step 3: Power Availability
- 11-12 Step 4: Power Supply Locations
- 13-14 Step 5: DC Renewable Power
- 15-16 Step 6: Power Cable Layout
- 17-18 Step 7: Cabling and Other Devices
- 19-22 Step 8: Control Solutions

DC FLEXZONE™ Suspension System

Step 1: Lighting Design

POWER

AC Branch Power ▶
 DC Renewable Power ▶
 (Optional)

Power Supplies ▶

Decide on the type of lights and design the lighting layout for the space using available DC FlexZone Compatible fixtures.



Lithonia Lighting T LED 2' x 2' fixture



Lithonia Lighting RT LED 2' x 2' fixture



Lithonia Lighting AL LED 2' x 2' fixture



DC FlexZone Compatible Lighting Partners

<p>Expanding the boundaries of lighting™</p>	Lithonia Lighting® AC Series LED – 2' x 2', 2' x 4' T Series LED – 2' x 2', 2' x 4' RT Series LED – 2' x 2', 2' x 4' VT Series LED – 2' x 2', 2' x 4' AL Series LED – 2' x 2', 2' x 4' Shadow Box Square Series LED – 2' x 2', 2' x 4' DOM™ Downlight
	Gotham® EVO® Downlight
	Peerless® Mino Luminaire
	Recessed Fluorescent Metalux® Accord™ – 2' x 2', 2' x 4' Metalux Ovation™ – 2' x 2', 2' x 4' Neoray™ Fenestra – 272 / 274 Neoray Luminous HE 282/284
	Recessed Fluorescent Aerion® – 2' x 2', 2' x 4' Equation™ – 2' x 2', 2' x 4' Luna® – 2' x 2', 2' x 4'
	Pendant Fluorescent Verve™ IV – Pendant
	LED T-BAR LED Smartlight™ – 2' and 4'
<p>T-BAR LED Smartlight™</p>	Recessed LED RLC22 - 2' x 2' RLS22 - 2' x 2'
	Recessed Fluorescent SoftTrace - 2' x 2' Attune - 2' x 4'
	Fluorescent Downlight Calculite® 6" Downlight



Consult directly with these Lighting Manufacturers for available fluorescent lamping and ballast combinations and all LED product details. Some DC FlexZone compatible lighting partners have multiple product family options available. Links to compatible product specifications are also available from www.armstrong.com/dcflexzone

INFRASTRUCTURE

PERIPHERALS

Structured Cabling & Interconnects

Powered Bus Bar Components
(DC FlexZone Suspension System)

Device Cabling & Interconnects

Lights, Sensors, etc.

CONTROLS

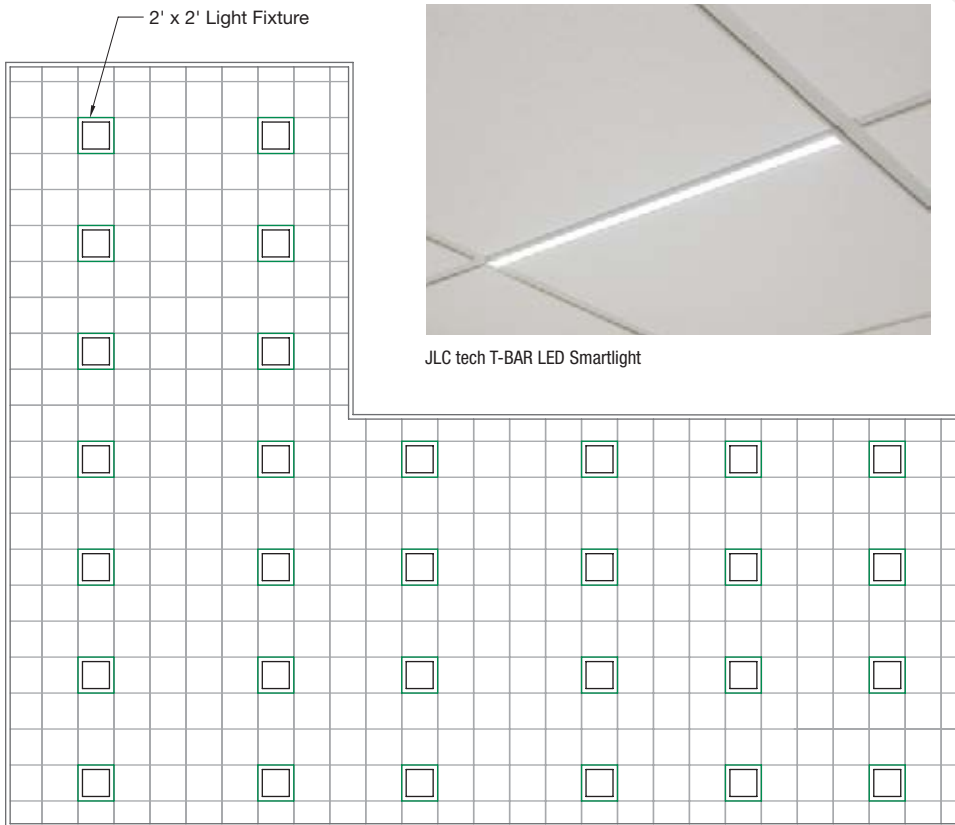
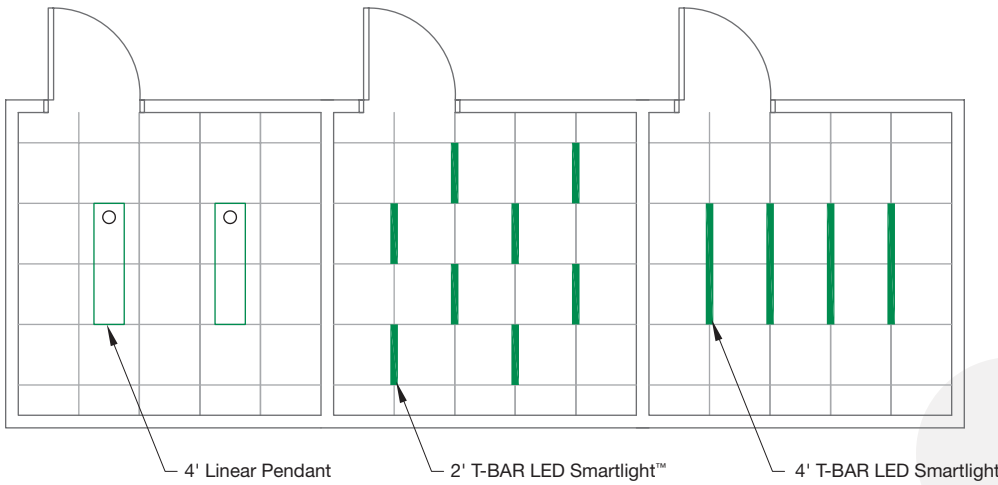

DC FLEXZONE™ Suspension System

Step 2: Ceiling Suspension System Layout

POWER

Power Supplies

AC Branch Power ▶

DC Renewable Power ▶

(Optional)

Review the Reflected Ceiling Plan (RCP) showing the DC FlexZone suspension system layout.

Consult Armstrong Architectural Design Guide CS-4324 for more information on how the DC FlexZone mains are typically shown on the RCP. If the DC FlexZone mains are not identified on the RCP, coordinate with the architect or interior designer on modifications to call out the DC mains. This is an important foundation for design of the room-level DC power distribution system.

- Identify which type of DC FlexZone Suspension System profile has been specified. This will affect the power and cabling designs.

(See two types of “Suspension System Profiles” at right.)

- Verify that the amount of power available (watts per square foot) at the ceiling plane is greater than the lighting power density required for that area.
- Also verify that building power is available near the application area for the low voltage DC power distribution.

Power availability should also be considered for other electrical devices such as sensors, controllers and future electrical loads in the space.

If a greater amount of available power is needed at the ceiling plane, then shorter length ceiling suspension system main beams should be used. Shorter length main beam will increase the power density available at the ceiling plane.

Please Note: Each electrical circuit on the powered main beams can only be connected to a maximum load of 100 watts. DC Suprafine main beams have one available circuit (on the top bus) and DC Silhouette main beams have two available circuits (on the top bus and in the bottom reveal).

(See “Electrical Capacity” and “Available Power” at right.)

electrical tips

Suprafine Suspension System Profile

DC FlexZone Suprafine® main beams have one available circuit on the top “bulb” of the suspension system.

DC SUPRAFINE MAIN BEAM

- ▲ AVAILABLE CIRCUIT: Conductors on bulb



Silhouette Suspension System Profile

DC FlexZone Silhouette® main beams have two available circuits, one on the top “bulb” and one within the bottom “reveal” of the suspension system. Either or both circuits may be separately powered in the electrical design.

DC SILHOUETTE MAIN BEAM

- ▲ FIRST AVAILABLE CIRCUIT: Conductors on bulb
- SECOND AVAILABLE CIRCUIT: Conductors inside reveal



Electrical Capacity

Each available circuit on a DC FlexZone main beam has a maximum electrical capacity of up to 100 watts. Actual maximum electrical capacity depends on the electrical output per channel from an EMerge Alliance® Registered power supply.

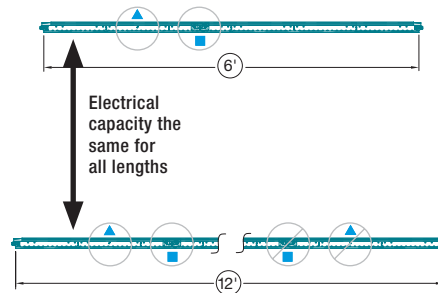

- ▲ FIRST AVAILABLE CIRCUIT: Conductors on bulb UP TO 100W
- SECOND AVAILABLE CIRCUIT: Conductors inside reveal UP TO 100W

Available Power Density

Shorter main beams increase the available power density of an area.

Six 12' DC Suprafine Mains = up to 600 watts/320 sf in this example

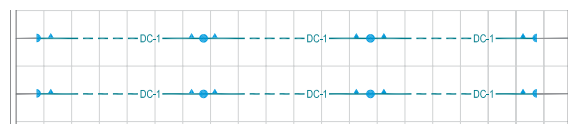

600 Watts

Twelve 6' DC Suprafine Mains = up to 1200 watts/320 sf in same example

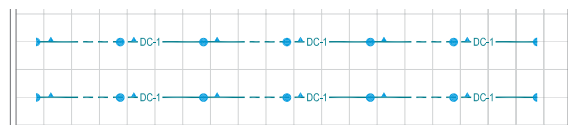

1200 Watts



It is critical for the Architect, Engineer and/or Lighting Designer to coordinate the ceiling suspension system and lighting layouts at this stage. If more power density or a different power distribution layout is required, the RCP or component selections may need to be revised.

INFRASTRUCTURE

PERIPHERALS

Structured Cabling & Interconnects ▶

Powered Bus Bar Components ▶
(DC FlexZone Suspension System)

Device Cabling & Interconnects ▶

Lights, Sensors, etc.
▼

CONTROLS

DC FLEXZONE Suprafine

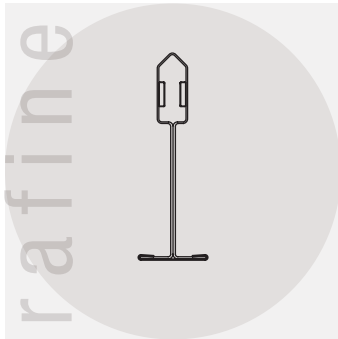

DC FlexZone Suprafine Main Beam Profile

Powering the Top Rail of DC FlexZone Suprafine Mains for Power Access Above the Ceiling Plane:

DC Suprafine Main Length	Watts/Sq Ft. of Available Power
12'	2
10'	2.5
8'	3
6'	4

Note: All main beams are assumed to be installed on 4' centers per standard suspended ceiling installation practice in the calculations above.

DC FLEXZONE Silhouette

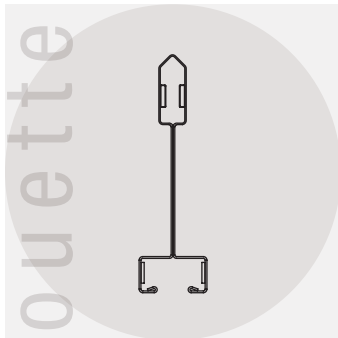

DC FlexZone Silhouette Main Beam Profile

Powering the Top Rail of DC FlexZone Silhouette Mains for Power Access Above the Ceiling Plane:

DC Silhouette Main Length	Watts/Sq Ft. of Available Power
12'	2
10'	2.5
8'	3
6'	4

Note: All main beams are assumed to be installed on 4' centers per standard suspended ceiling installation practice in the calculations above.



IMPORTANT: Powering both circuits on any DC FlexZone Silhouette main would double the electrical capacity of that main beam, but the available power should still be identified as separate 24VDC circuits.



DC FLEXZONE™ Suspension System

Step 2: Ceiling Suspension System Layout

POWER

Power Supplies

AC Branch Power ▶
DC Renewable Power ▶
(Optional)

- After DC FlexZone main beams have been installed by the acoustical contractor as part of an acoustical ceiling suspension system, qualified electricians make all electrical connections to conductors on DC mains.
- Each DC main is designed to mate with EMerge Alliance® Registered power distribution cable assemblies at designated locations along the length of each main.
- Each DC main is considered a Class 2 circuit(s) when electrically connected.
- DC mains are intended to deliver 24 Volt Direct Current (DC) power to one or more electrical devices equipped with EMerge compliant connectors that are flexibly connected to suspension system.

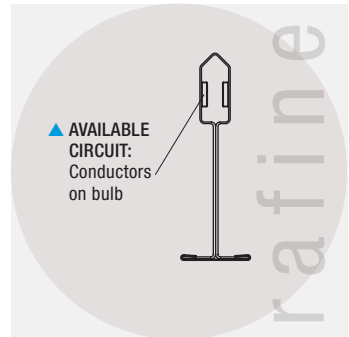
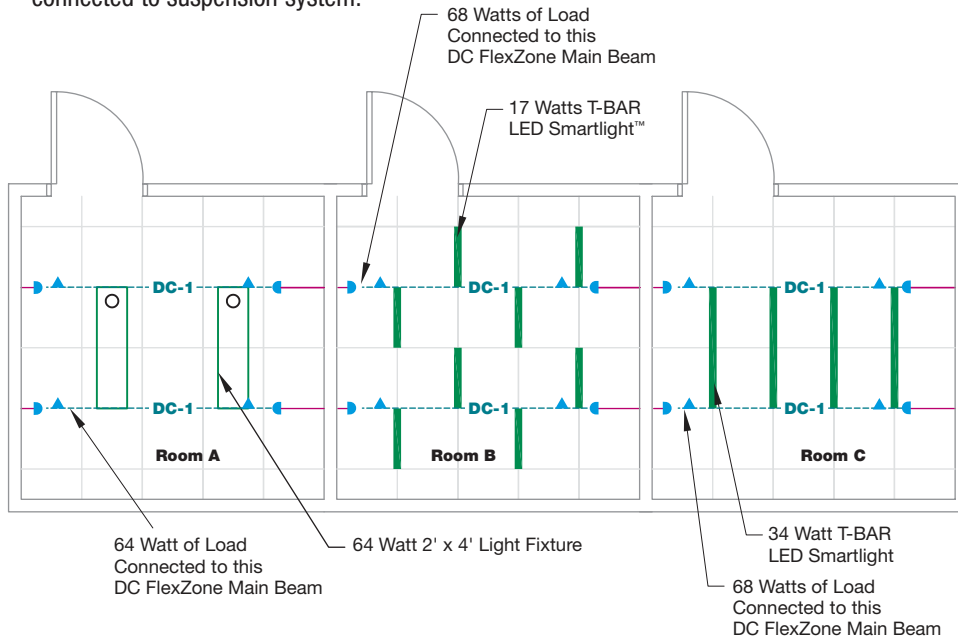

DC FlexZone Suprafine Main Beam Profile

suprafine

Drawing Key

- ▲ Power Key Slot on the Bulb for Electrical Connection to the Grid
- ▶ End of DC FlexZone Main Beam Connected to Border Main
- Mechanical Connection of Two DC FlexZone Main Beams
- Light Fixture
- DC-1 DC FlexZone Suprafine Main Beam (1 circuit available)

Sample Lighting Fixture Schedule

Type of Lighting Fixtures	How Fixture is Connected to the Suspension System (Top or Bottom Circuit)	Watts Per Fixture	Total Wattage (6 Fixtures)
Room A (Pendent Light)	Top	64	128
Room B (2' T-BAR LED)	Top	17	136
Room C (4' T-BAR LED)	Top	34	136

DC FlexZone Suprafine Electrical Circuit Availability

How Main Beams are Powered	Circuits Per Main Beam	Number of DC FlexZone Suprafine Main Beams	Total Number of Circuits	Available Wattage
Only the Top	1	6	6	600

Note: Other typical ceiling layouts can be seen in the Architectural Design Guide.

INFRASTRUCTURE

PERIPHERALS

Structured Cabling & Interconnects

Powered Bus Bar Components
(DC FlexZone Suspension System)

Device Cabling & Interconnects

Lights, Sensors, etc.

CONTROLS

How DC Mains and Border Mains are Shown on the RCP

DC Main to DC Main Connection

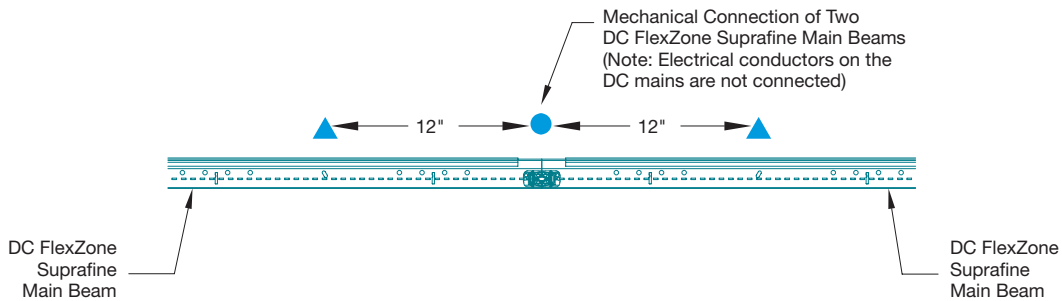

DC Main to Border Main Connection

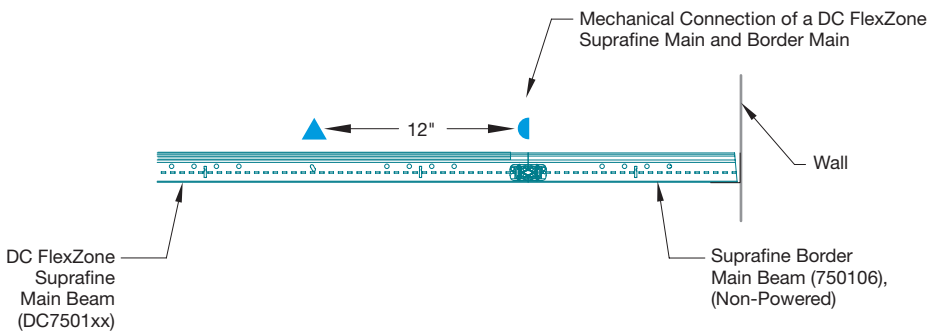

Power-in Key Slot Locations

Power-in key slots for a DC FlexZone™ Suprafine® main beam are located 12" from each end.

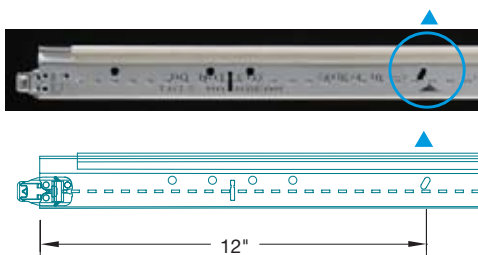

electrical tip

Important: Power will not always be available along the room perimeters because non-powered border mains are installed acoustically in those locations.



DC FLEXZONE™ Suspension System

Step 2: Ceiling Suspension System Layout

POWER

Power Supplies

AC Branch Power ▶
DC Renewable Power ▶
(Optional)

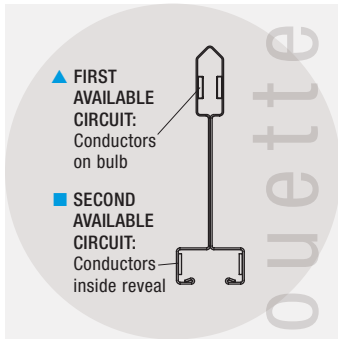

DC FlexZone Silhouette Main Beam Profile

silhouette

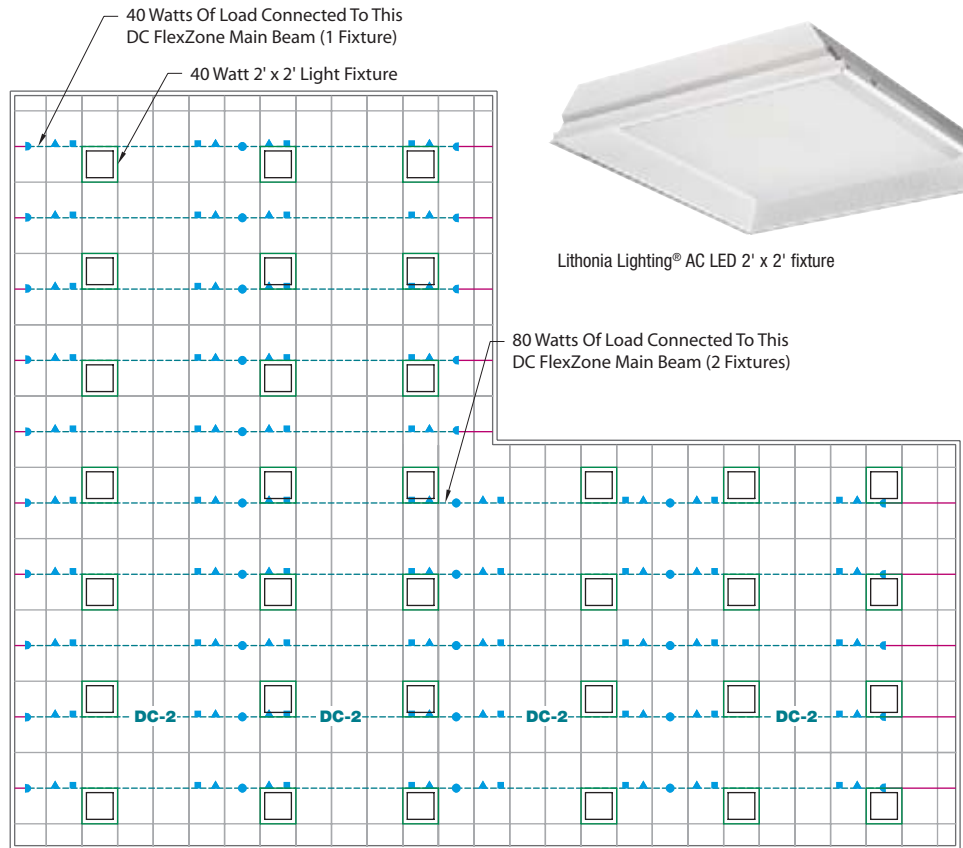

Drawing Key

- ▲ Power Key Slot on the Bulb for Electrical Connection to the Grid
- Power Key Slot for Electrical Connection to Bottom Reveal Area of Grid
- ▶ End of DC FlexZone Main Beam Connected to Border Main
- Mechanical Connection of Two DC FlexZone Main Beams
- Light Fixture
- DC-2** DC FlexZone Silhouette Main Beam (2 separate circuits available)

Note: Other typical ceiling layouts can be seen in the Architectural Design Guide.

Sample Lighting Fixture Schedule

Type of Lighting Fixtures	How Fixture is Connected to the Suspension System (Top or Bottom Circuit)	Watts Per Fixture
Recessed 2' x 2' Light Fixture	Top	40

DC FlexZone Silhouette Electrical Circuit Availability

How Main Beams are Powered	Circuits Per Main Beam	Number of DC FlexZone Silhouette Main Beams	Total Number of Circuits	Available Wattage
Only the Top	1	30	30	3000
Only the Bottom	1	30	30	3000
Top and Bottom	2	30	60	6000

INFRASTRUCTURE

PERIPHERALS

Structured Cabling & Interconnects

Powered Bus Bar Components
(DC FlexZone Suspension System)

Device Cabling & Interconnects

Lights, Sensors, etc.

CONTROLS

How DC Mains and Border Mains are Shown on the RCP

DC Main to DC Main Connection

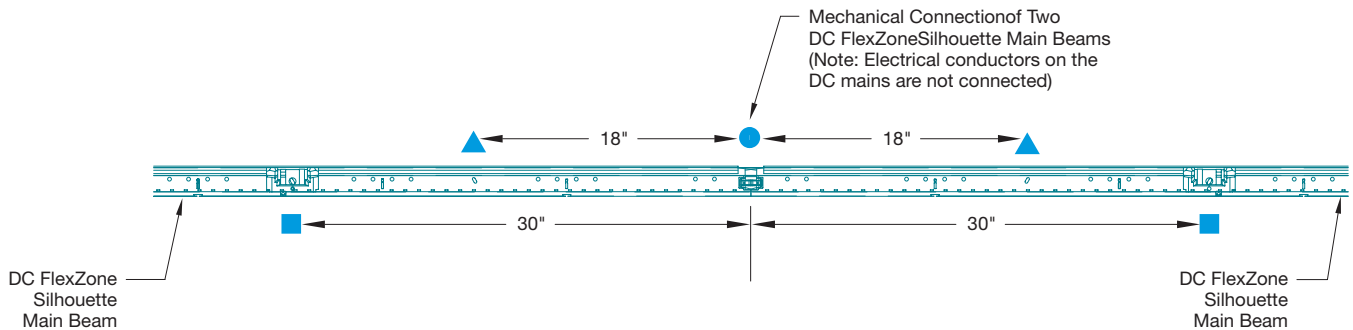

DC Main to Border Main Connection

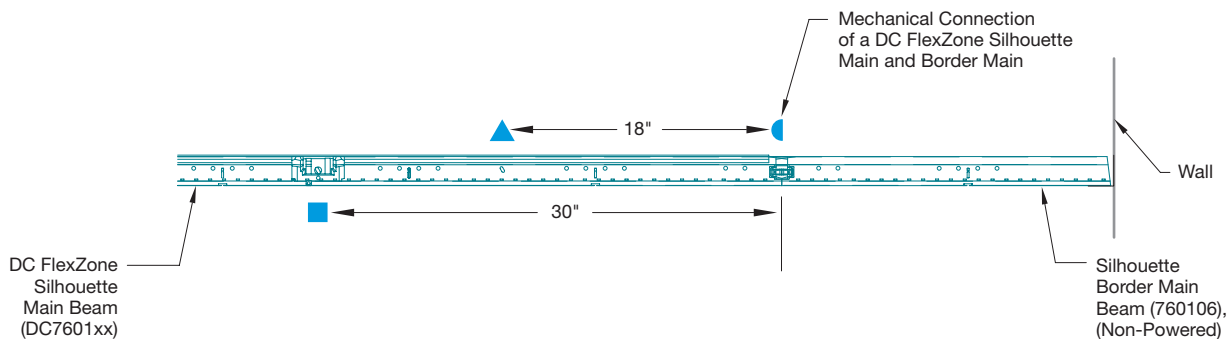

Electrical Capacity

Power-in key slots for a DC FlexZone Silhouette® main beam are located 18" from each end for the top "bulb" circuit and 30" from each end for the bottom "reveal" circuit.

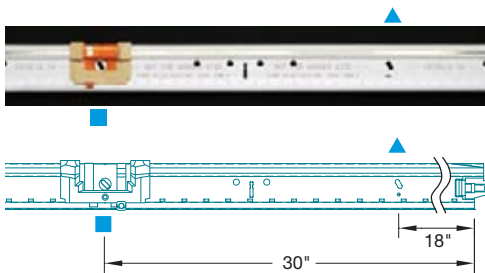

Important: Power will not always be available along the room perimeters because non-powered border mains are installed acoustically in those locations.



electrical tip

DC FLEXZONE™ Suspension System

Step 3: Power Availability
Step 4: Power Supply Locations

POWER

Power Supplies ▶

Verify Voltages Available

AC Branch Power ▶
DC Renewable Power ▶
(Optional)

- A. Decide on the type and size of power supply unit for the installation.
- B. Choosing the best power supply for your installation depends on the size of the project, the number of powered DC FlexZone main beams required, their specific location in the ceiling plane and whether or not you plan to connect the power supply to a renewable power source.
 - a. Note: The ROAL Safe Energy Server has 4 channels with the ability to expand up to 16 channels by adding multiple units from a single VAC connection point. The Nextek Power Supply only has a 16 channel option, but can be connected to a renewable source.
- C. Verify the voltages available to connect to the AC-DC power supply.
 - a. Note: The input voltage of the ROAL Safe Energy Server is rated for 120-240 VAC and the Nextek Power Supply Module is 208-240 Volts AC. Consult with ROAL Electronics or Nextek Power Systems for alternative input voltages (277 VAC) with the use of an auto transformer.
- D. Consult directly with ROAL Electronics and Nextek Power Systems for specifications on their power supply and an overall power system design. Links are also available from www.armstrong.com/dcflexzone



Power Supply Location Layout

Layout of the power supplies will be based primarily on the type of DC FlexZone ceiling suspension system being used, the number of DC FlexZone main beams, and their location in the plan.

General Estimating Tips:

These are based on DC FlexZone Main Beams spaced 4' on center.

- E. Two ROAL 4 channel Safe Energy Servers will power 8 DC FlexZone powered main beams, covering approximately 400-500 SF of ceiling.
- F. One Nextek Power Supply module will power 16 DC FlexZone powered main beams, covering approximately 800-1000 SF of ceiling.

2 SES Units:
400 - 500 sf

1 PSM Unit:
800 - 1000 sf

Location Considerations:

The location and layout of the power supplies in relation to the DC FlexZone main beams will also directly affect the length of the power feed cables needed to complete the power distribution infrastructure. Therefore, **please read step 6** before starting the power supply layout.

The location of the DC FlexZone main beams in reference to the location of the power supplies will also determine the number of power supplies. Room design, odd shape rooms, wall locations, and plenum obstructions may affect the power supply density and placement.



ROAL Safe Energy Server



Nextek Power Supply Module

IMPORTANT: A DC FlexZone main beam should be located within approximately 30 linear feet of a power supply.

electrical tip

INFRASTRUCTURE

PERIPHERALS

Structured Cabling & Interconnects

Powered Bus Bar Components
(DC FlexZone Suspension System)

Device Cabling & Interconnects

Lights, Sensors, etc.

CONTROLS

suprafine

120-240 VAC

Two 4 Channel ROAL Safe Energy Servers

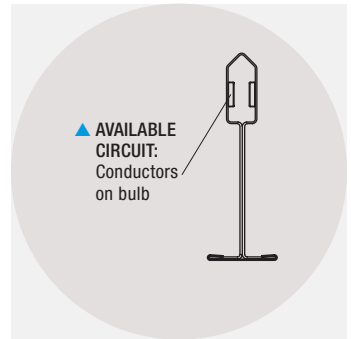
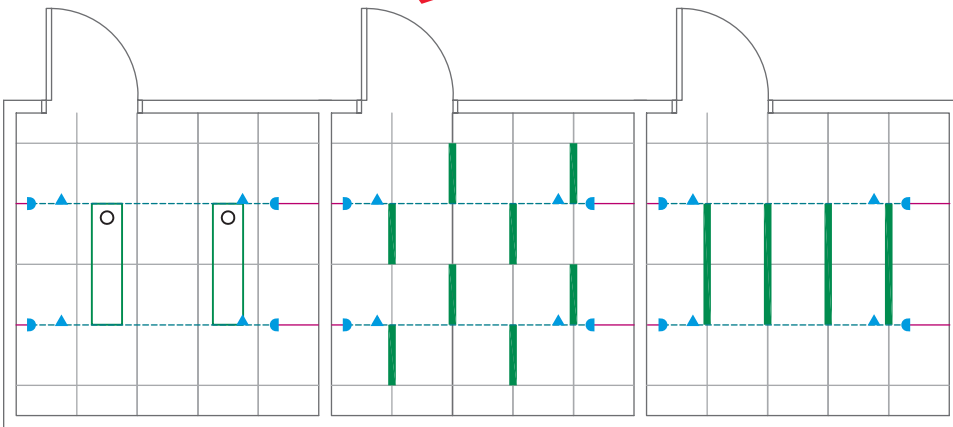

DC FlexZone Suprafine Main Beam Profile

silhouette

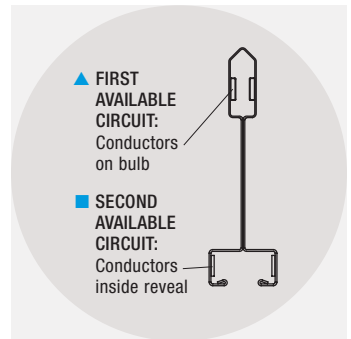
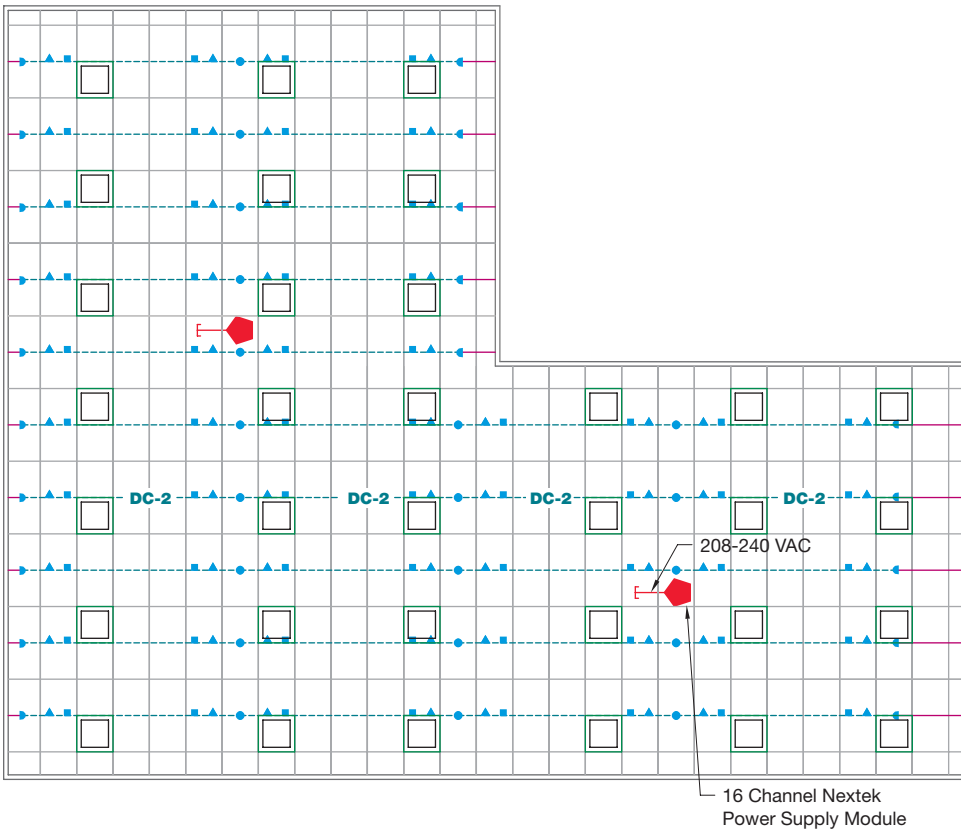

DC FlexZone Silhouette Main Beam Profile

Drawing Key

- ▲ Power Key Slot on the Bulb for Electrical Connection to the Grid
- Power Key Slot for Electrical Connection to Bottom Reveal Area of Grid
- End of DC FlexZone Main Beam Connected to Border Main
- Mechanical Connection of Two DC FlexZone Main Beams
- ⬠ Power Supply Module or Safe Energy Server

DC FLEXZONE™ Suspension System

Step 5: DC Renewable Power (Optional)

POWER

Power Supplies

Selecting the DC-DC Converter

AC Branch Power ▶
DC Renewable Power ▶
(Optional)

The DC-DC converter should be used with a renewable power source.

Note: The Nextek DC-DC converter must be used in conjunction with the AC-DC power supply module on a one-to-one scale.



Consult directly with Nextek Power Systems on DC-DC power converter specifications, wire sizing and overall power system design. Links are also available from www.armstrong.com/dcflexzone



DC-DC Converter Selection

Location and layout of the DC-DC converter will be based primarily on the location of the AC-DC power supply.

Guidelines for selecting a DC-DC converter:

DC-DC Converter Size	Low Voltage	High Voltage	Fixed Voltage
Output Power (To an AC-DC Power Supply Module)	1600 Watts	1600 Watts	1600 Watts
Range of Input Voltage (From Renewable Source)	70-240 Volts DC	240-390 Volts DC	350-400 Volts DC
Output Voltage (From DC-DC Converter)	24.5 Volts DC	24.5 Volts DC	24.5 Volts DC

Location Considerations:

The location and layout of the DC-DC converter shall be in close proximity to the location of the AC-DC power supply module.



Nextek DC-DC converter

electrical tip



IMPORTANT: A DC-DC converter should be located within approximately 10 feet of an AC-DC power supply.

INFRASTRUCTURE

PERIPHERALS

Structured Cabling & Interconnects

Powered Bus Bar Components
(DC FlexZone Suspension System)

Device Cabling & Interconnects

Lights, Sensors, etc.

CONTROLS

suprafine

silhouette

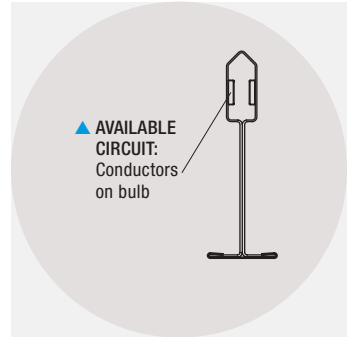
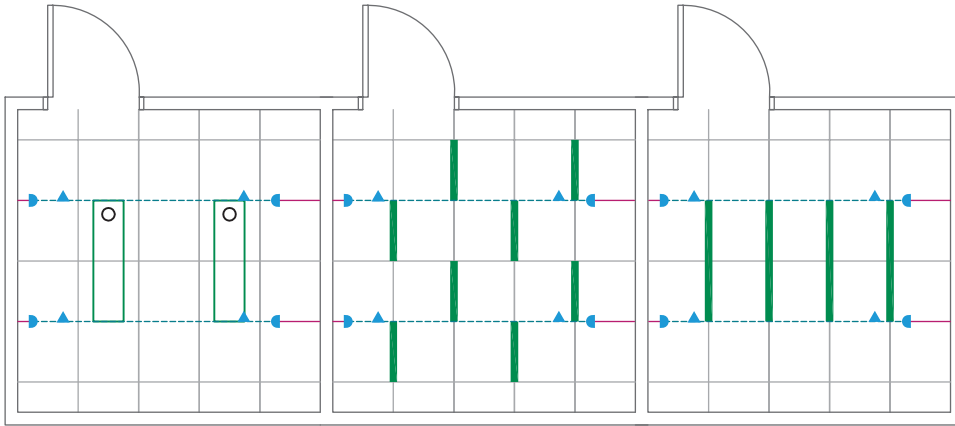
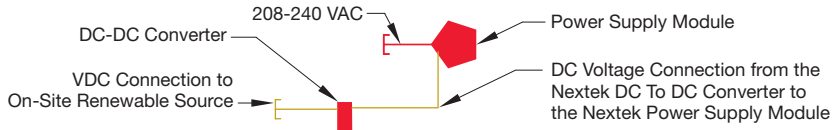

DC FlexZone Suprafine Main Beam Profile

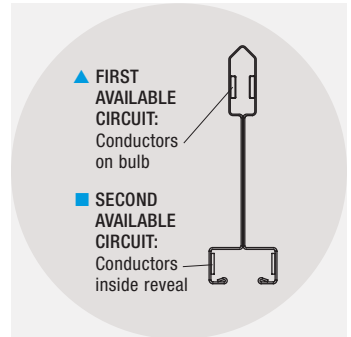
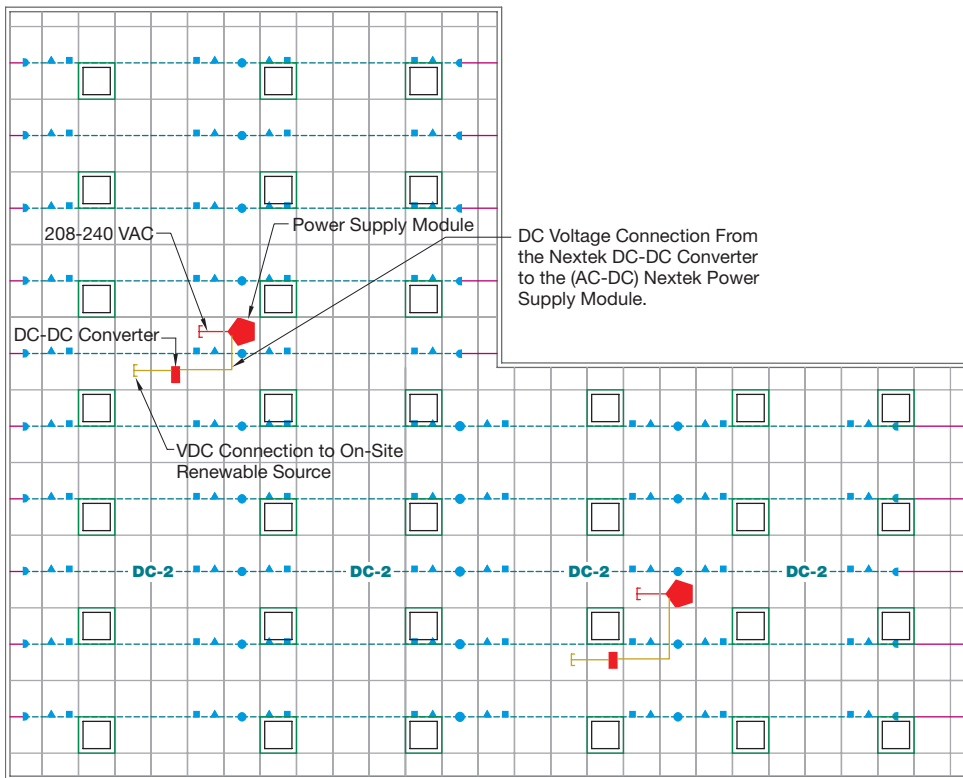

DC FlexZone Silhouette Main Beam Profile

Drawing Key

- ▲ Power Key Slot on the Bulb for Electrical Connection to the Grid
- Power Key Slot for Electrical Connection to Bottom Reveal Area of Grid
- ▶ End of DC FlexZone Main Beam Connected to Border Main
- Mechanical Connection of Two DC FlexZone Main Beams
- ◆ Power Supply Module
- DC-DC Converter

DC FLEXZONE™ Suspension System

Step 6: Power Cable Layout

POWER

Power Supplies

AC Branch Power ▶
DC Renewable Power ▶
(Optional)

Decide on the length and layout of the power feed assemblies.

The layout of the power feed cabling is directly related to the linear distance between the power supply and the DC FlexZone main beam.

Pre-engineered, fixed length power cable assemblies are available to connect power from the power supply to DC FlexZone main beams. These are typically available (from others) in lengths of 5', 10', 15', 20', 25' and 30'.

The distance between a power supply and the power-in location on a DC main beam should be within approximately 30 linear feet.



▶ Consult directly with TE Connectivity on power feed cable assembly lengths and specifications. Links are also available from www.armstrong.com/dcflexzone

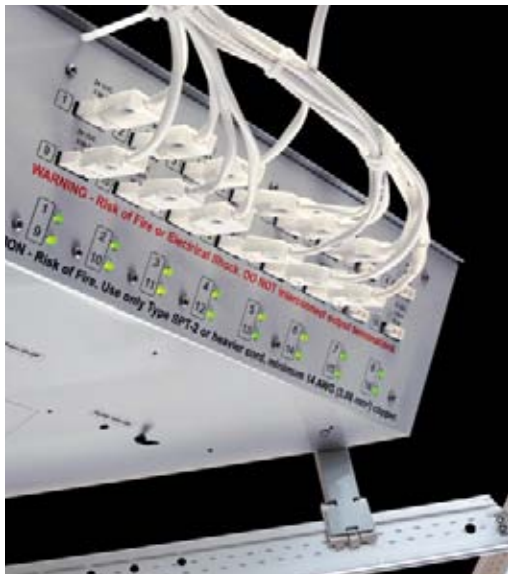

Nextek power supply module and TE Connectivity cabling

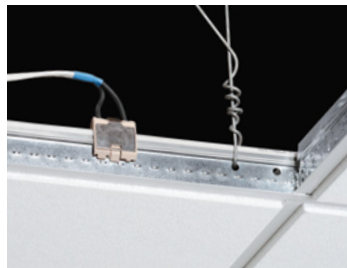

DC FlexZone Silhouette with TE Connectivity low voltage DC power feed cable assemblies, (above)



DC FlexZone Silhouette with TE connectivity low voltage Internal Bus Bar Connector, (left)

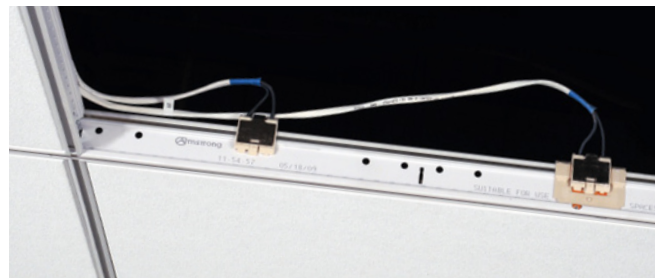

DC FlexZone Silhouette with TE Connectivity low voltage DC power feed cable assemblies, (right)

Cabling Power-in Key Slots

Power feed cable assemblies connect to the DC FlexZone main beams at the power-in key locations.

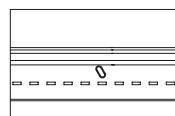

DC Silhouette and DC Suprafine Mains (Power-in Key Slots for Top Bus Bar)

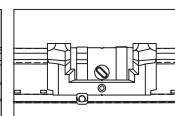

DC Silhouette Mains Only (Power-in Key Slots for Bottom Bus Bar)

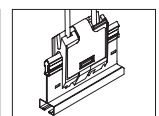
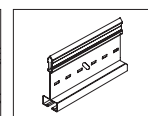

IMPORTANT: The linear distance of required cabling does not always follow a straight line. Other HVAC, electrical and plumbing equipment also occupies the plenum space and may create obstacles or conflicts.

Power supplies feeding adjacent rooms and available wall penetrations for cabling should also be considered.

electrical tip

INFRASTRUCTURE

PERIPHERALS

Structured Cabling & Interconnects

Powered Bus Bar Components
(DC FlexZone Suspension System)

Device Cabling & Interconnects

Lights, Sensors, etc.

CONTROLS

suprafine

silhouette

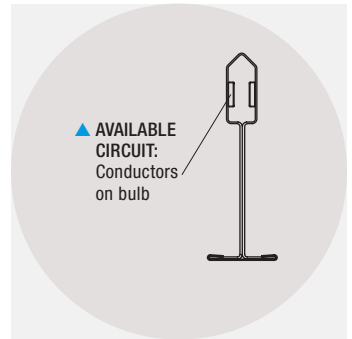
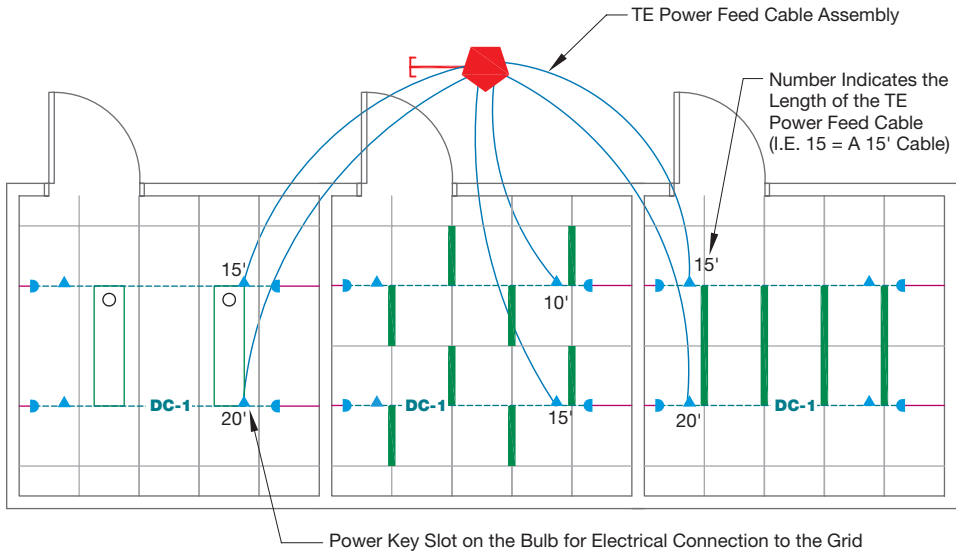

DC FlexZone Suprafine Main Beam Profile

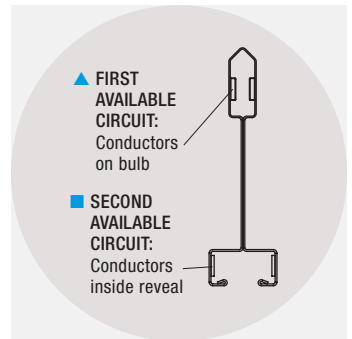
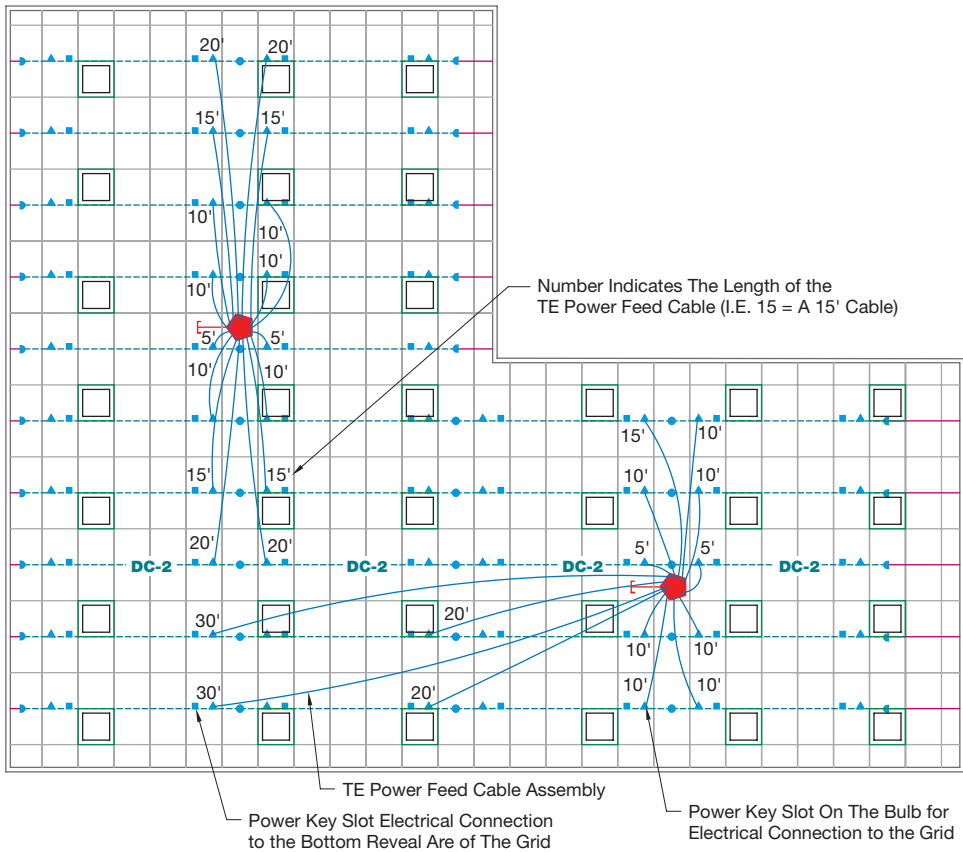

DC FlexZone Silhouette Main Beam Profile

Drawing Key

- ▲ Power Key Slot on the Bulb for Electrical Connection to the Grid
- Power Key Slot for Electrical Connection to Bottom Reveal Area of Grid
- ▶ End of DC FlexZone Main Beam Connected to Border Main
- Mechanical Connection of Two DC FlexZone Main Beams
- Power Feed Cable Assembly

DC FLEXZONE™ Suspension System

Step 7: Cabling & Other Devices

Decide on the length and layout of the device cable assemblies to the electrical load devices getting their power from the DC FlexZone ceiling suspension system.

Pre-engineered device cable assemblies connect power from a powered main beam to an electrical device. These are typically available in 5' or 10' lengths but custom length options may also be available.

IMPORTANT: These connectors and device cable assemblies are generally specified as part of the device specification, such as for a light fixture or sensor.



Consult directly with cabling and/or device manufacturers with any questions or custom requests.

(Other device connector options such as integral bus bar connectors for DC FlexZone Silhouette suspension system and device chassis connectors may also be available from TE Connectivity. Contact them directly for details.)



Focal Point Luna® light fixture with load device cable assembly in DC FlexZone Suprafine suspension system

POWER

Power Supplies

AC Branch Power ▶
DC Renewable Power ▶
(Optional)

AcuityBrands.
Expanding the boundaries of lighting™

COOPER Lighting

CRESTRON

ENCELIUM

FOCAL POINT®

JLC • tech

OSRAM SYLVANIA

PHILIPS Day-Brite

PHILIPS LIGHTOLIER

TE
connectivity

E Merge™
ALLIANCE
REGISTERED

INFRASTRUCTURE

PERIPHERALS

Structured Cabling & Interconnects

Powered Bus Bar Components
(DC FlexZone Suspension System)

Device Cabling & Interconnects

Lights, Sensors, etc.

CONTROLS

suprafine

silhouette

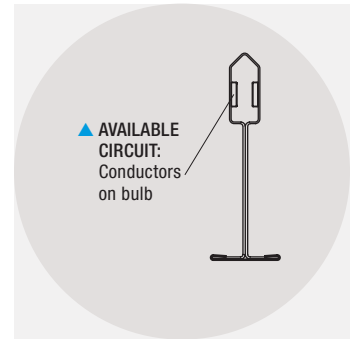
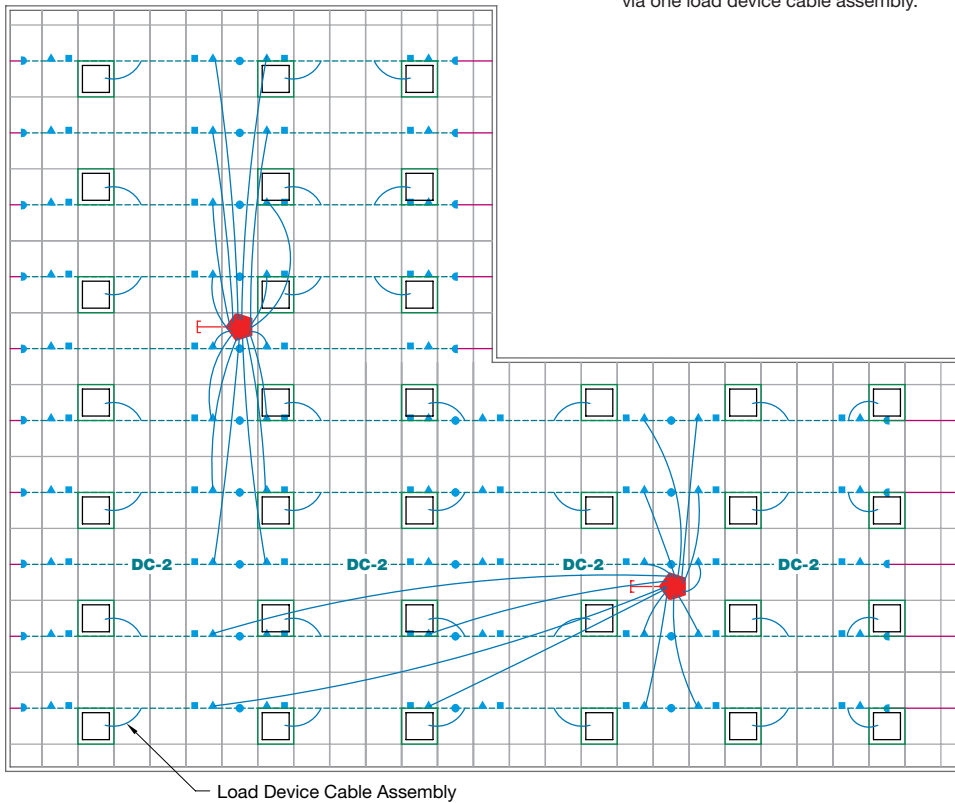
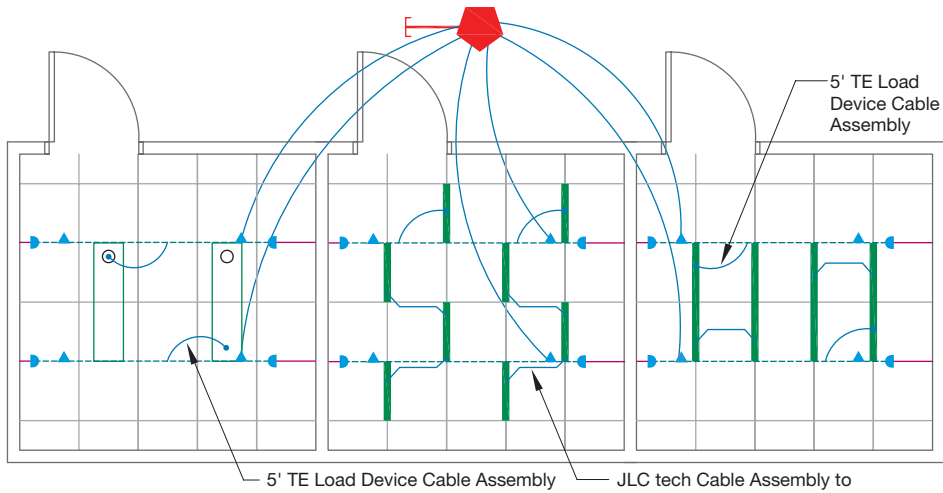

DC FlexZone Suprafine Main Beam Profile

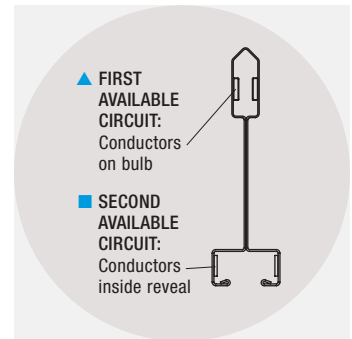

DC FlexZone Silhouette Main Beam Profile

Drawing Key

- ▲ Power Key Slot on the Bulb for Electrical Connection to the Grid
- Power Key Slot for Electrical Connection to Bottom Reveal Area of Grid
- ◐ End of DC FlexZone Main Beam Connected to Border Main
- Mechanical Connection of Two DC FlexZone Main Beams
- ↪ Load Device Cable Assembly

DC FLEXZONE™ Suspension System

Step 8: Control Solutions

POWER

AC Branch Power ▶
DC Renewable Power ▶
(Optional)

Power Supplies ▶

The flexibility of a low voltage, plug and play, room-level DC power distribution system can be further enhanced by choosing wireless, device level solutions as part of the control design.

Wireless control solutions at a device level or room level are available using switched 24 VDC and / or 0-10 VDC dimming controls (via wireless communication).

A variety of wired control solutions both at the device and bus levels can also be designed. For example, **wired control at a device level or room level** could use 0-10 volt dimming controls via control wiring on a dimmable ballast or relay.

Wired control solutions for bus switching rather than device-level control are also available. This could include using relays to turn on and off the power being supplied to each of the powered DC FlexZone main beams. This type of less flexible control solution involves intercepting the power feed assemblies going to the DC Mains with off-the-shelf relays.

Moving up from the room-level applications, DC FlexZone Compatible controls can also be integrated into building-level automation and control systems.

▶ Consult directly with Crestron Electronics and Encelium on control products and design guide solutions for DC FlexZone applications. Links to their DC FlexZone Compatible products are also available from www.armstrong.com/dcflexzone



Crestron photocell sensor



Crestron occupancy sensor



Encelium I/O module



Crestron wireless controller module



Encelium ECU

INFRASTRUCTURE

PERIPHERALS

Structured Cabling & Interconnects

Powered Bus Bar Components
(DC FlexZone Suspension System)

Device Cabling & Interconnects

Lights, Sensors, etc.

CONTROLS

suprafine

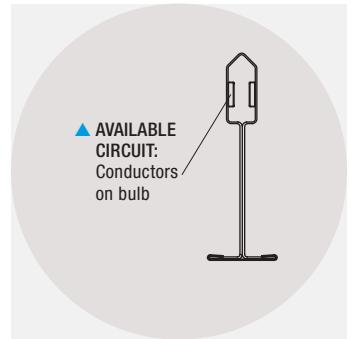
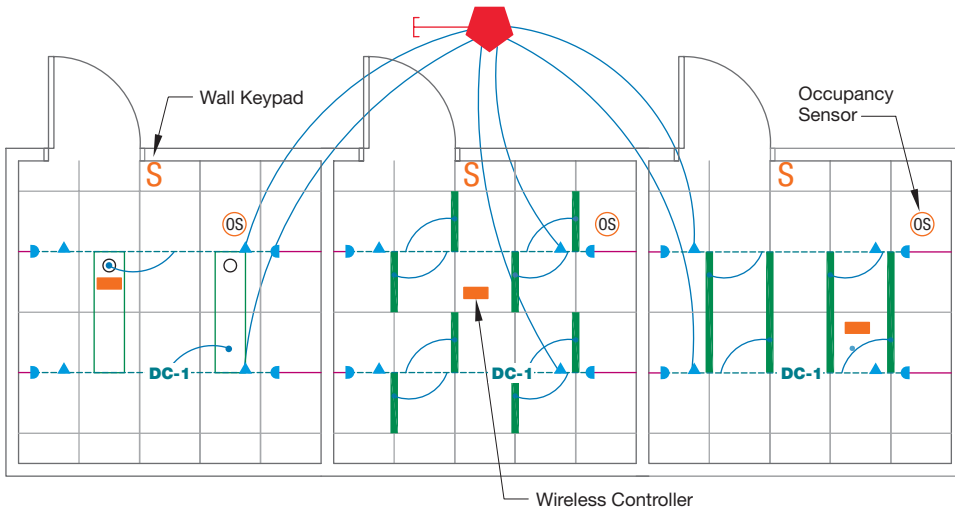

DC FlexZone Suprafine Main Beam Profile

silhouette

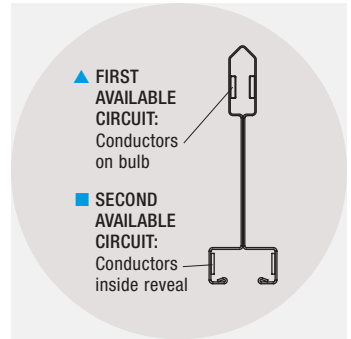
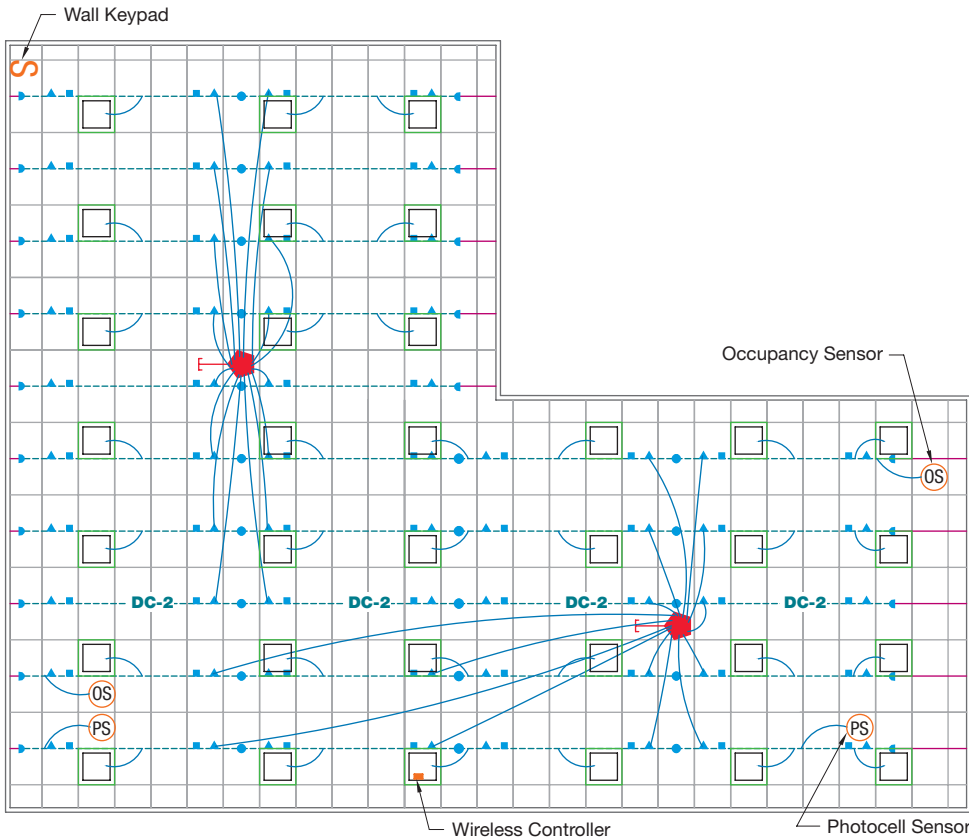

DC FlexZone Silhouette Main Beam Profile

Drawing Key

- ▲ Power Key Slot on the Bulb for Electrical Connection to the Grid
- Power Key Slot for Electrical Connection to Bottom Reveal Area of Grid
- ▶ End of DC FlexZone Main Beam Connected to Border Main
- Mechanical Connection of Two DC FlexZone Main Beams
- OS Occupancy Sensor
- PS Photocell Sensor
- Wireless Controller
- S Wall Keypad

DC FLEXZONE™ Suspension System

Step 8: Control Solutions

POWER

Power Supplies

AC Branch Power ▶
DC Renewable Power ▶
(Optional)

This diagram illustrates multiple ways of applying the Crestron Wireless Controller. Each row of lighting, identified by its number, is configured differently:

1. A single wireless controller is powered by the Armstrong DC FlexZone suspension system. The wireless controller then passes a 0-10V dimming control circuit as well as 24VDC power circuit to each lighting fixture.
2. A single wireless controller is powered by the Armstrong DC FlexZone suspension system. The wireless controller then passes a 0-10V dimming control circuit to multiple fixtures, but only passes 24VDC power circuit to one light fixture. The second fixture is independently powered directly by the Armstrong DC FlexZone suspension system.
3. Each lighting fixture and the wireless controller are independently powered directly from the Armstrong DC FlexZone suspension system. The wireless controller passes a 0-10V dimming circuit to each fixture attached. This 0-10V control circuit is daisy-chained across multiple light fixtures.
4. Each light fixture is independently powered from the Armstrong DC FlexZone suspension system and controlled by a single wireless controller.

Note: In a typical system, photocells, key pads, and occupancy sensors can be connected to the nearest wireless controller.

▶ Consult directly with Crestron Electronics on control products and design guide solutions for DC FlexZone applications. Links to their DC FlexZone Compatible products are also available from www.armstrong.com/dcflexzone

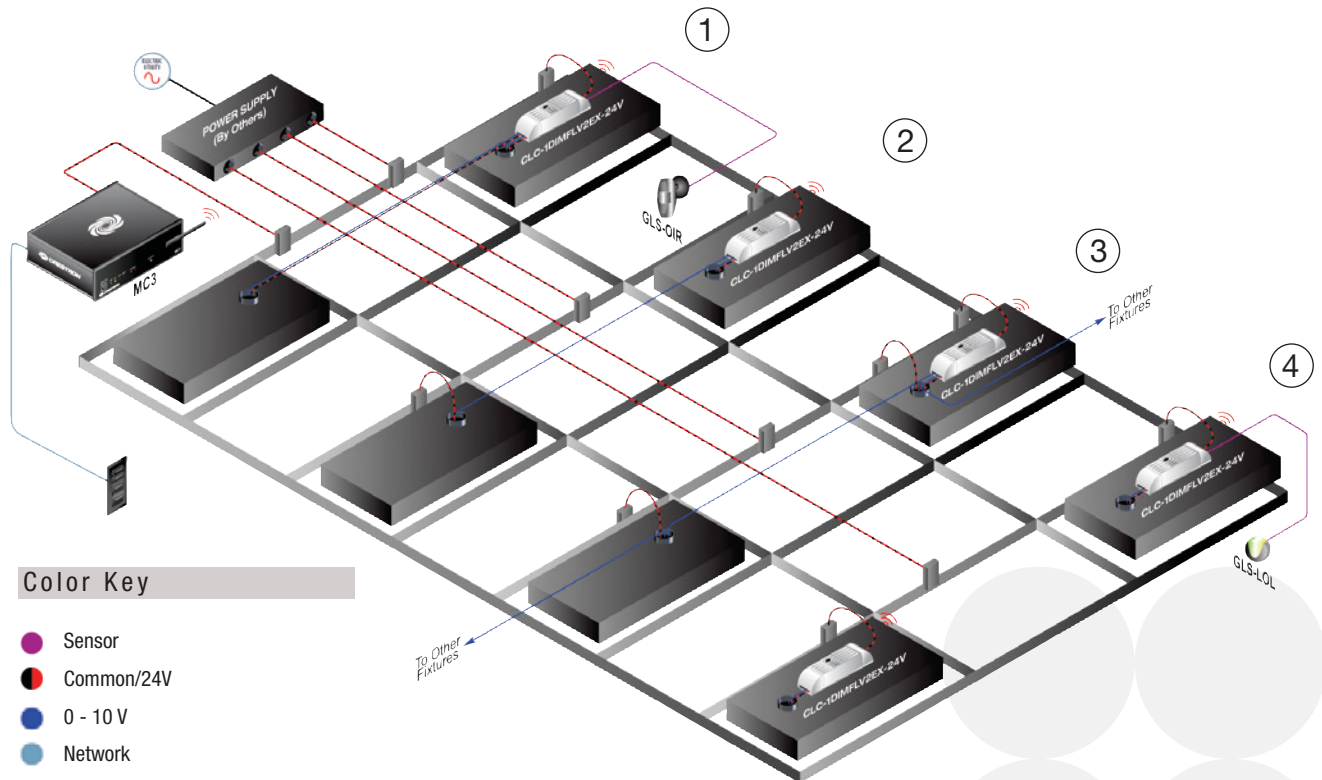

INFRASTRUCTURE

Structured Cabling & Interconnects

Powered Bus Bar Components
(DC FlexZone Suspension System)

Device Cabling & Interconnects

PERIPHERALS

Lights, Sensors, etc.

CONTROLS

This diagram illustrates multiple ways of applying the Encelium Lighting Control System for smart buildings.

The ENCELUM™ Energy Management System (EMS) was designed from the ground up as an integrated lighting control and energy management system that greatly reduces lighting energy consumption while improving lighting quality and personal lighting comfort. Addressable

fixture level dimming and switching controls coupled with easy to use control software allows the ENCELUM EMS to respond dynamically to the ever changing characteristics of a building by always providing the right amount of light when and where required.

ENCELUM

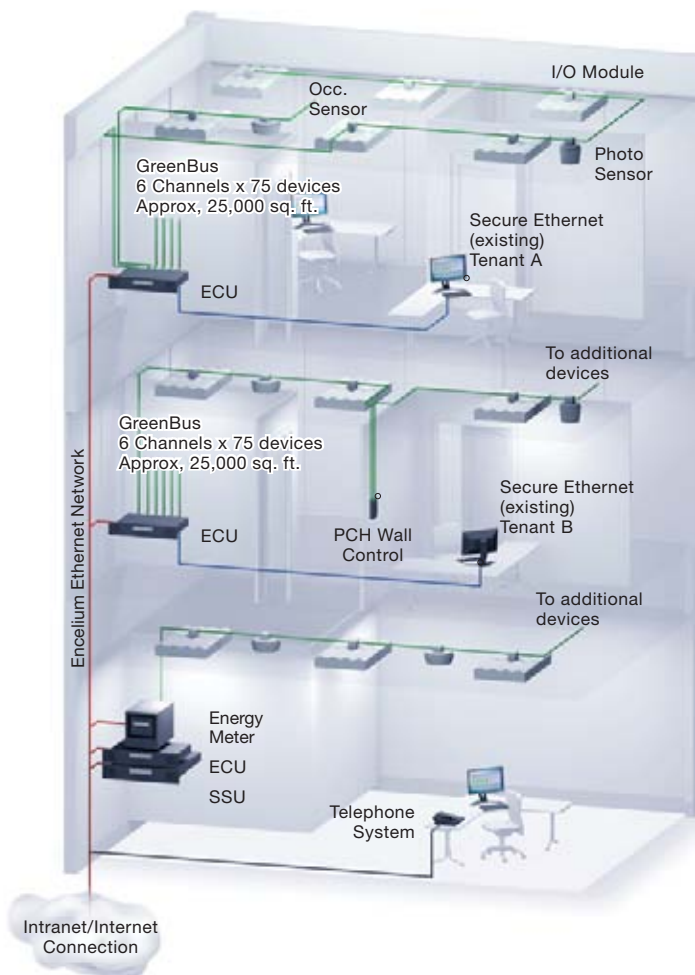

Consult directly with Encelium on control products and design guide solutions for DC FlexZone applications. Links to their DC FlexZone Compatible products are also available from www.armstrong.com/dcflexzone

System Architecture

The GreenBus I™ is a low-cost, high reliability communication means to report sensor information back to the ENCELUM Energy Management System (EMS). This illustration shows how each component is easily integrated into the EMS. Each light fixture, sensor and wall controller is daisy-chained back to the Energy Control Unit (ECU) using pre-terminated 'click & go' GreenBus I™ communication cabling. Based on the position of light fixtures and sensors, an optimum wiring path is determined utilizing supplied pre-terminated cables. As the modules obtain power via the GreenBus I network. ECUs typically control individual floors and are linked via an Ethernet Network. Internet or LAN connection allows Windows floor plan based control software to be operated anywhere on the network.

DC FLEXZONE™ Suspension System Systems

DC FlexZone

Compatible Partners

- Power, infrastructure, lighting, and control companies to help complete your DC power distribution system
- Light fixtures are compatible with DC FlexZone 9/16" Suprafine® and 9/16" Silhouette® with 1/4" reveal



Expanding the boundaries of lighting™



armstrong.com/dcflexzone

- Latest product and program news
- Real-time selection and specification tools
- Contacts – reps, where to buy, who will install
- Online catalog, submittal pages and CAD details
- Literature and sample information
- Please see **Architectural Design Guide (CS-4324)** for acoustical drawings, details, and specification information for DC FlexZone Suspension Systems.

1 877 ARMSTRONG (276-7876)

- Name of your Armstrong Representative
- TechLine – Technical information, detail drawings, CAD design assistance, installation information, other technical services – 8 a.m. to 5:30 p.m. EST, Monday through Friday. FAX 1-800-572-8324 or email: techline@armstrong.com
- Product literature and samples – Express service or regular delivery

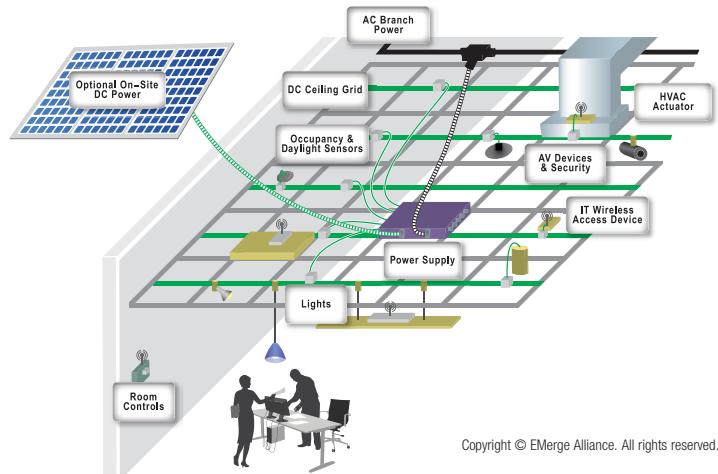

Copyright © EMerge Alliance. All rights reserved.

Visit emergealliance.org for more information on their platform of DC power distribution standards.

All trademarks used herein are the property of AWI Licensing Company and/or its affiliates and DC FlexZone compatible partners
© 2013 AWI Licensing Company • Printed in the United States of America

TechLine™ / 1 877 ARMSTRONG

1 877 276 7876

armstrong.com/dcflexzone

BPCS-4325-413

